

order number	lens name	f-stop
0009-192-000-41	Macro-CCD-Lens -1x 4	4
0009-192-000-42	Macro-CCD-Lens -1x 5.6	5.6

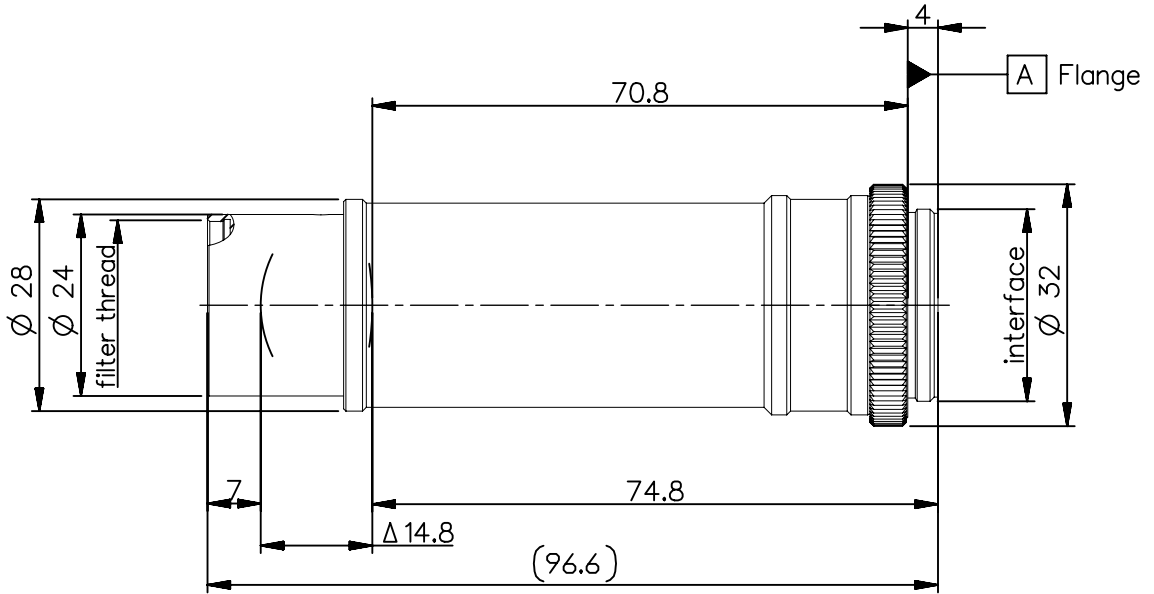

Specification		ON			
image circle max. (mm)	11	working distance (mm)	90		
focal length f' (mm)	50.0	interface	C-mount		
magnification β' [range]	-1	filter thread	M22.5 x0.5		
spectral range λ (nm)	400 - 750	weight (g)	70		
schematic diagram		*) in air			
		design includes CCD cover glass: no			
		SF (mm)	-47.2	f-stop	
		S'F' (mm) *)	38.5	\varnothing EnP	
		HH' (mm) *)	0.5	\varnothing Exp	
		SH (mm)	2.8		
		S'H' (mm) *)	-11.5		
		S'EnP (mm)			
		S'Exp (mm) *)			

NX PROTECTIVE NOTE "DIN ISO 16016" TO BE OBSERVED	EU-D	AL-T1A	US-D	US-ML	not export controlled		
	REV	ECC	DATE	APPROVED	PDM Status		
	a	neu			Freigabe	-	
	b	08-0281	24.11.08	Strozew	SCALE	1:1	
	c	11-0358	20.07.11	Kuehne	MATERIAL		
	d	12-0185	28.03.12	Schuber	TITLE		
	e	14-0184	17.09.14	Schiffe	Macro-CCD-Lens -1x		
	f	14-0184	17.08.15	Hornbog	FIRST	DATE	NAME
g	17-0915	05.12.17	Denk	ISSUE	17.09.14	Schifferer	
				CHKD	17.09.14	Stauder	
DIN A 4	ALL DIMENSIONS ARE IN MM AND INCLUDE SURFACE TREATMENT					DRAWING NO. 0009-192-100-00-0001g	SHEET 1 OF 1
				REPLACES			