



soberton inc.

# SP DYNAMIC SPEAKER UNIT

Acoustic Product Specification

Product Number: SP-3606



Release | Revision: C/2018

## CONTENTS

This document contains the technical specifications for the dynamic speaker unit.

**Page 1**  
Speaker Electroacoustic Characteristics

General Specifications

**Page 2**  
Reliability Tests

**Page 3**  
Measuring Method (Speaker Mode)

Standard Test Condition of Speakers

**Page 4**  
Frequency Response Curve

**Page 5**  
Dimensions

**Page 6**  
Packing

## Dynamic Speaker Electroacoustic Characteristics

### Sound Pressure Level

87±3dB SPL @0.8, 1.0, 1.2 and 1.5KHz in average  
Measuring Condition: 0.1W (Sine wave) 10cm measured with baffler

### Frequency Response Curve

As shown in Figure 2

### Response Frequency

550±20%Hz @ 1V (Without Baffler)

### Input Power (Nominal and Maximum)

Rated Noise Power 0.5W  
Short Term Max Power: 0.8W must be normal at a white noise (1.0W, F0 ~ 20KHz) for one minute

### Operation Test

Must be free audible noise (buzzes and rattles)  
(300 ~ 9KHz frequency range, input level up to 2.0Vrms)

### Distortion

Less than 5% @1KHz, 0.1M, 0.1W

## General Specifications

### Operating Temperature Range

-20°C ~ +60°C

### Storage Temperature Range

-30°C ~ +70°C

### Standard Test Conditions

Temperature 17°C ~ 25°C  
Relative Humidity 45% ~ 80% (RH)

### AC Impedance

8±15%Ω(@2KHz 1V without baffler.

### DC Resistance

7.4±15%Ω

### Dimension

ø36.0 x H5.5mm

### IP Level

No rating



soberton inc.

## SP DYNAMIC SPEAKER UNIT

Acoustic Product Specification

Product Number: SP-3606



Release | Revision: C/2018

### CONTENTS

This document contains the technical specifications for the dynamic speaker unit.

#### Page 1

Speaker Electroacoustic Characteristics

General Specifications

#### Page 2

Reliability Tests

#### Page 3

Measuring Method (Speaker Mode)

Standard Test Condition of Speakers

#### Page 4

Frequency Response Curve

#### Page 5

Dimensions

#### Page 6

Packing

## Reliability Tests

The sound pressure as specified will neither deviate more than  $\pm 3\text{dB}$  from the initial value, nor have any significant damage after any of following testing.

### High Temperature Test

High Temperature  $+70\pm 2^\circ\text{C}$

Duration 96 hours

### Low Temperature Test

Low Temperature  $-30\pm 2^\circ\text{C}$

Duration 96 hours

### Heat Shock Test

High Temperature  $+70\pm 2^\circ\text{C}$

Low Temperature  $-30\pm 2^\circ\text{C}$

Changeover time < 30 seconds

Duration 1 hour

Cycle 100

### Humidity Test

Temperature  $+40\pm 2^\circ\text{C}$

Relative Humidity 90%~95%

Duration 96 hours

### Temperature Cycle Test

Temperature  $-30^\circ\text{C}$   $+70^\circ\text{C}$

Duration 45 minutes 45 minutes

Temperature gradient 1 ~  $3^\circ\text{C}/\text{min}$

Cycle 25

### Drop Test

Mounted with dummy set mass: 100 g

Height 1.5 m

Cycle 6 (1 each plain) Onto the concrete board

### Load Test

Speaker mode: White noise (EIA filter) for 96 hours @ 0.5W input power



soberton inc.

# SP DYNAMIC SPEAKER UNIT

Acoustic Product Specification

Product Number: SP-3606



Release | Revision: C/2018

## CONTENTS

This document contains the technical specifications for the dynamic speaker unit.

**Page 1**  
Speaker Electroacoustic Characteristics

General Specifications

**Page 2**  
Reliability Tests

**Page 3**  
Measuring Method (Speaker Mode)

Standard Test Condition of Speakers

**Page 4**  
Frequency Response Curve

**Page 5**  
Dimensions

**Page 6**  
Packing

## Measuring Method (Speaker Mode)

### Standard Test Condition

Temperature 15 ~ 35°C

Relative humidity 45% ~ 85%

Atmospheric pressure 860mbar to 1060mbar.

### Standard Test Fixture

Input Power 0.1W

Zero Level -dB

Mode TSR

Potentiometer Range 50dB

Sweep Time 0.5sec

## Standard Test Condition of Speaker (Fig. 1)

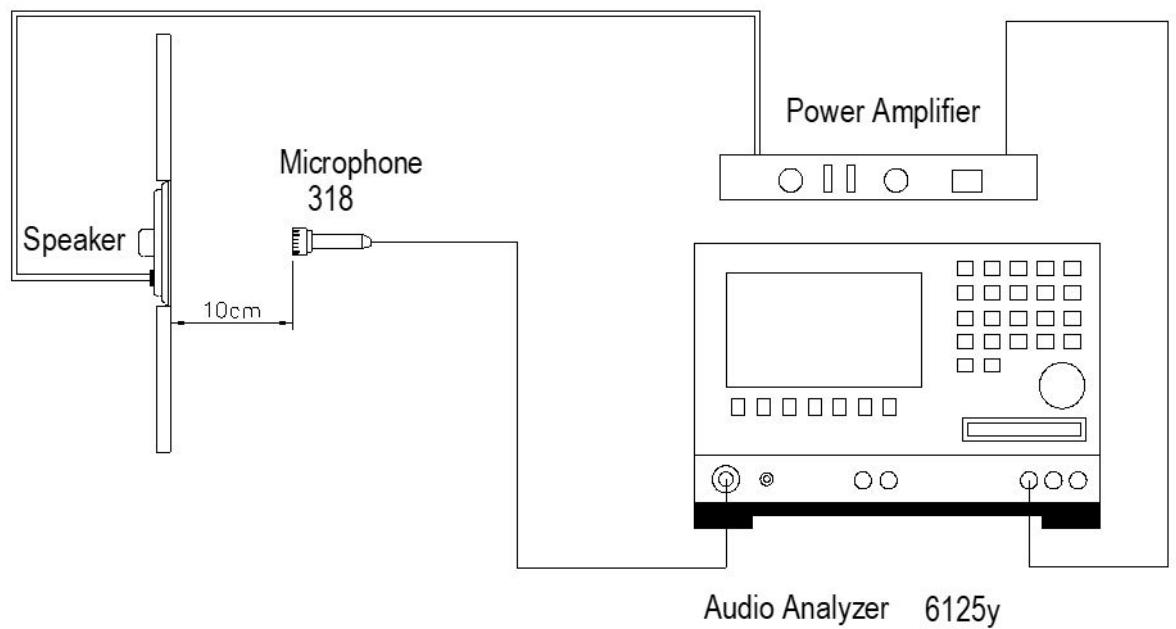



soberton inc.

# SP DYNAMIC SPEAKER UNIT

Acoustic Product Specification

Product Number: SP-3606



Release | Revision: C/2018

## CONTENTS

This document contains the technical specifications for the dynamic speaker unit.

### Page 1

Speaker Electroacoustic Characteristics

General Specifications

### Page 2

Reliability Tests

### Page 3

Measuring Method (Speaker Mode)

Standard Test Condition of Speakers

### Page 4

Frequency Response Curve

### Page 5

Dimensions

### Page 6

Packing

## Frequency Response Curve (Fig. 2)

0.1W/10cm, in free air

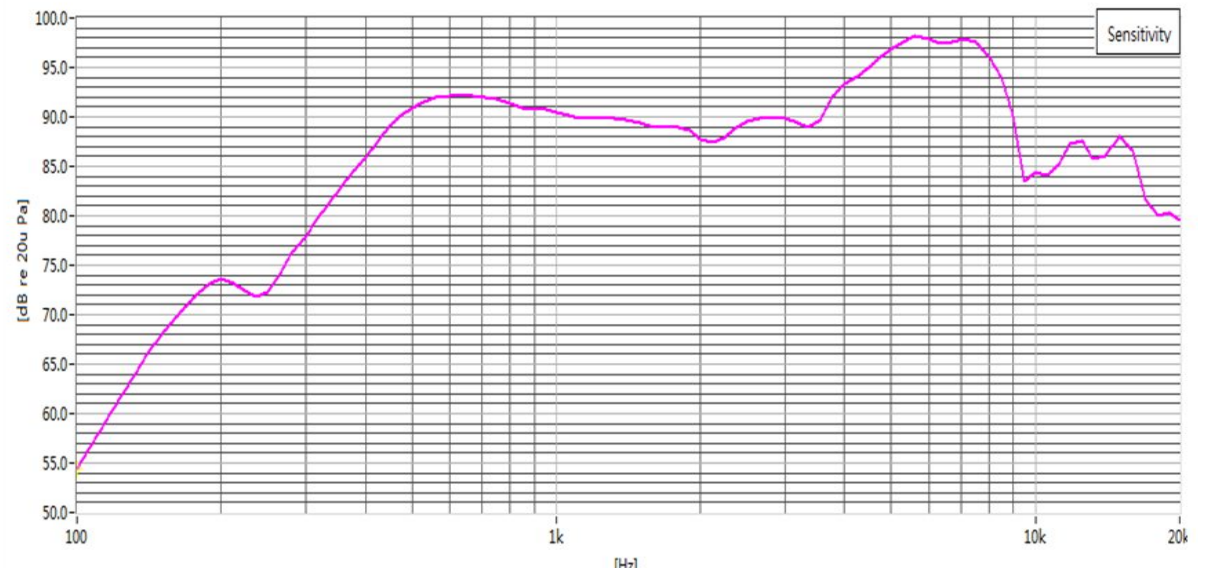



soberton inc.

# SP DYNAMIC SPEAKER UNIT

Acoustic Product Specification

Product Number: SP-3606



Release | Revision: C/2018

## CONTENTS

This document contains the technical specifications for the dynamic speaker unit.

### Page 1

Speaker Electroacoustic Characteristics

General Specifications

### Page 2

Reliability Tests

### Page 3

Measuring Method (Speaker Mode)

Standard Test Condition of Speakers

### Page 4

Frequency Response Curve

### Page 5

Dimensions

### Page 6

Packing

## Dimensions

Tolerance:  $\pm 0.5$  (unit: mm)

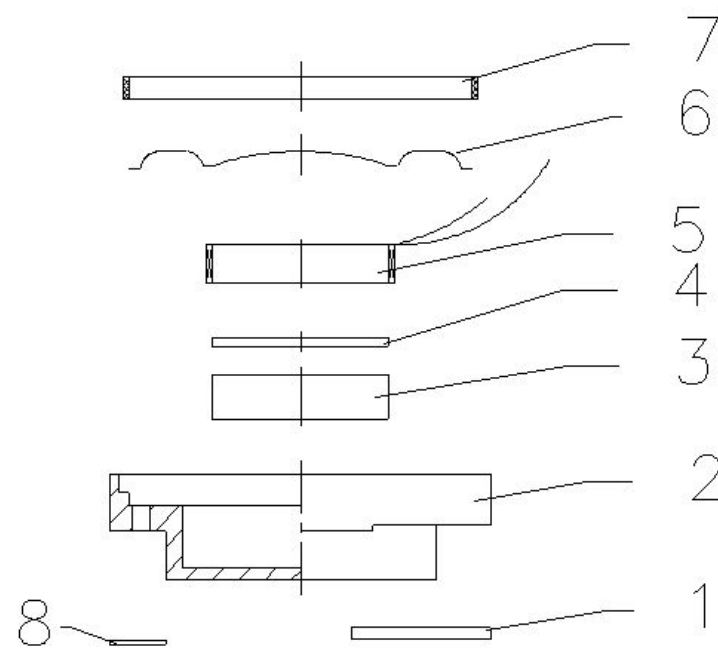
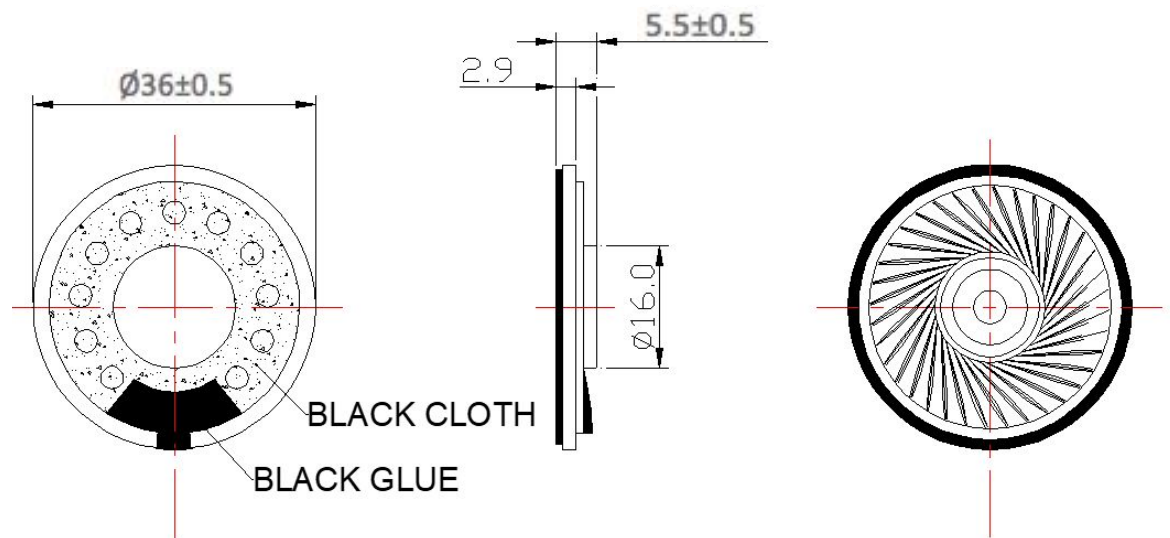

No.	Part Name	Material	Quantity
1	PCB	FR-4	1
2	Frame	SPCC	1
3	Magnet	Nd Fe B	1
4	Plate	SPCC	1
5	Voice Coil	Cu	1
6	Diaphragm	PET	1
7	Gasket	Paper	1
8	Silk Screen	Adhesive	1



soberton inc.

# SP DYNAMIC SPEAKER UNIT

Acoustic Product Specification

Product Number: SP-3606



Release | Revision: C/2018

## CONTENTS

This document contains the technical specifications for the dynamic speaker unit.

### Page 1

Speaker Electroacoustic Characteristics

General Specifications

### Page 2

Reliability Tests

### Page 3

Measuring Method (Speaker Mode)

Standard Test Condition of Speakers

### Page 4

Frequency Response Curve

### Page 5

Dimensions

### Page 6

Packing

## Packing

$$42\text{PCS} \times 24 = 1008\text{PCS}$$

