

# ERbic

---

Bus Interface Connector System



# ERbic - BUS INTERFACE CONNECTOR SYSTEM

The development of bus systems for industrial applications began in 1983. To be more accurate, it was the use of serial data transmission which brought about the breakthrough. In 1988, field bus systems were still new in industrial automation and a great deal of effort was required to win customers. But within a very short time, so-called field bus systems have gained acceptance to an extent that no one could have dreamed of.

This has only been possible because customers have simply been made aware of a clear product advantage. From then on, it was no longer necessary to individually wire device for device and signal for signal; instead so-called "bus nodes" could be installed, which communicate with one another by means of a 2-wire cable and pass on commands to the input and output modules. This way, installation expense and the possibility of faults were considerably reduced. Added to this are features such as remote diagnostics, parameter setting and modularity, to name but a few. Of the multitude of field buses that came onto the market, some have almost disappeared again. The large control system manufacturers are trying to establish their systems in the marketplace through so-called user organizations, e.g. PNO (Profibus User Organization), CiA (CAN in Automation), SafetyBUS p (SafetyBUS Club), and other marketing activities.

A fundamental difference is constituted by the different network topologies. Hence, there are line, ring or star configurations. All have their particular advantages and disadvantages. Device hierarchies are also possible: master-slave systems or multi-master systems.

A characteristic of the line configuration is that the bus must be "terminated" by means of a resistor at the end of the line in order to avoid effects such as reflections, which may interfere with the communication.

Devices within the line are cabled by "looping through". Here, the T function, which enables the bus to operate when the plug is removed, is of particular interest.

ERNI is currently concentrating on Profibus, CAN bus and SafetyBus p versions where customer-specific solutions e.g. for Bitbus, Interbus, etc. also exist at the same time

In the meantime, some bus systems have been internationally standardized. The so-called physical layer is also defined in these standards, which, among other things, specify the cable, the connectors and the contact assignment. There are still differences with regard to the protection class. Different plug connectors are recommended depending on this. The term "light duty" is used with IP 20 and "heavy duty" with IP 65/67.



# ERNI BUS INTERFACE CONNECTOR, ERbic FOR SHORT

The interface plugs of the ERbic line for various bus systems offer different features and advantages. They are based on D-Sub interface technology. All ERbics have compact external dimensions. There are versions with horizontal and vertical cable outlets.

Both pure node versions and pure termination versions are available as well as nodes with a connectable termination resistor. The node (without termination resistors) is used within the length of a line and the termination (with termination resistors) at the end of the line. The node with a connectable termination resistor can be used virtually anywhere. The latter is simply configured as a termination by changing the position of the switch.

The housings of the pure terminations are a different color than the nodes. The end of the line is therefore immediately recognizable.

The bus systems are also different colors. The user can therefore easily find their way around within a system.

A T function is provided in all ERbics. A device can therefore be changed while the bus is running. The types with a connectable termination resistor are primarily suitable for customers with reduced storage or when setting up, extending or converting large systems.

Certain types are reversed with regard to the face of the connector, allowing the direction of the cable outlet to be determined. This is achieved by a special pin arrangement in the D-Sub connector.

However, the standard direction of the cable outlet is matched to the devices of the market leaders and should therefore be used for new designs.

A further outstanding feature is the termination technology. Depending upon the type, ERbics are available with screw terminals, cage-clamp terminals or insulation-displacement contact (IDC) terminals.

Terminations using the FastConnect principle, for example, are therefore possible.

The development of field buses in the direction of safety-related applications is also satisfied by corresponding further advancement of the ERbic line. There is a Profibus Ex i version, which was developed together with a customer, or a SafetyBus p version.

As an alternative to the plastic housing, the newly developed ERbic MAX has recently been introduced to the market. This has a metal housing and an axial cable outlet. It is particularly suitable for harsh environments and offers space advantages at the field device when several interfaces are present.

The metal housing provides excellent electromagnetic compatibility (EMC).

## FEATURES



Common ERbic design for different bus systems. Versions for Profibus, CAN bus and SafetyBus p. Different colors among buses.



Node with connectable termination resistor



Integral T function, bus in, bus out



Support for max. data rates, e.g. Profibus, 12 Mbit/s through integral inductances



Pure nodes and termination versions. Color differentiation between node and termination within the bus

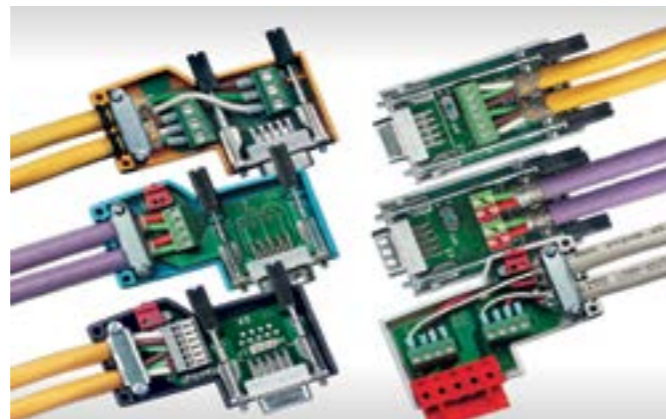

Flexibility through different termination technologies

## FEATURES



Full metal version for particularly severe loading



Reversed version for determining the cable outlet direction



Horizontal or vertical cable outlet



Versions with second D-Sub as service interface and externally connectable termination resistor

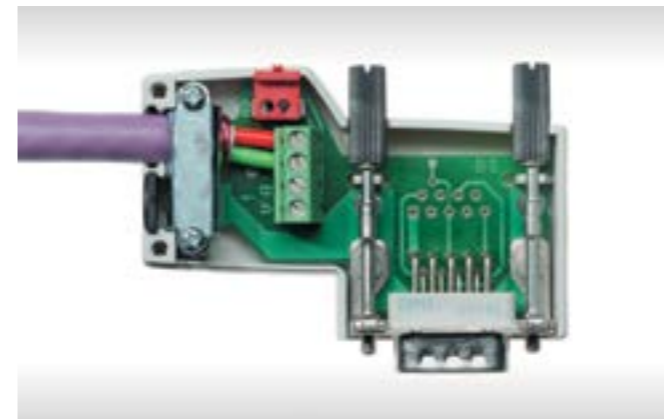

Reliable cable strain relief with shield connection



Special versions on request

# APPLICATIONS



# DIMENSIONAL DRAWINGS

## ERbic

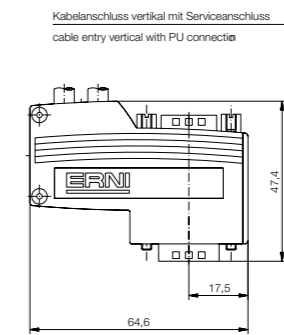
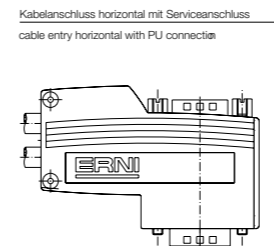
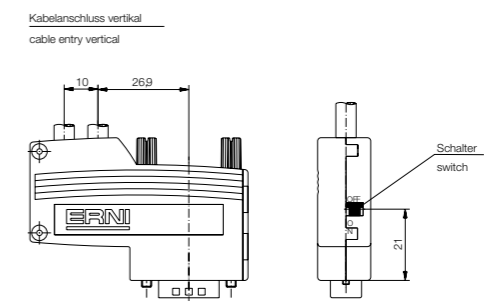
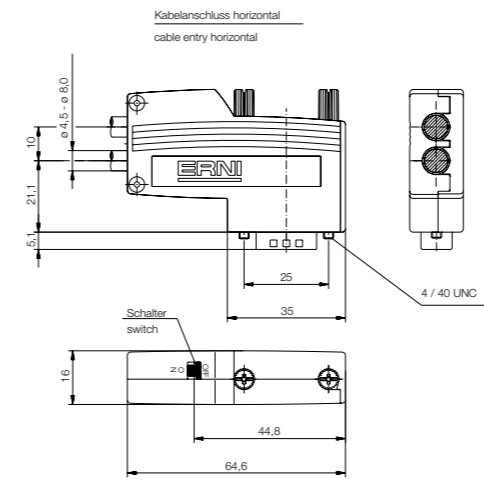

## ERbic MAX

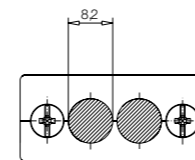
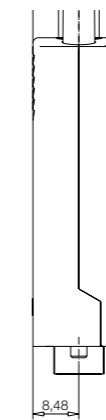
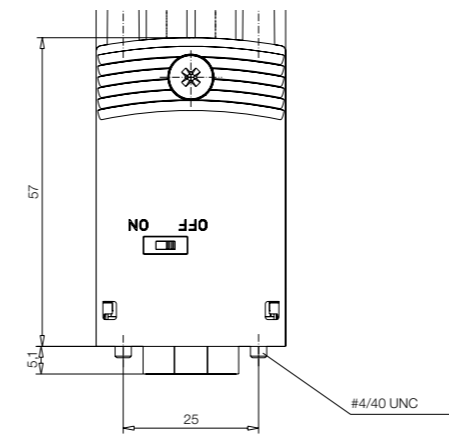

All dimensions in mm

# ERBIC PROFIBUS

Profibus is the most widely used field bus. It is promoted by interested and committed manufacturers and users in the PNO (Profibus user organization). The IP 20 interface on the device side is standardized as a 9-pin D-Sub female connector. The maximum data transmission rate is 12 Mbit/s. The cable is a shielded twisted pair conductor. The cable sheath is violet and the signal cores are green (A) and red (B). With its comprehensive program, ERNI provides customers with a wide variety of options. Particular emphasis should be placed on the different termination technologies, from the traditional screw terminal to the cage clamp terminal to the IDC terminal.\*



## Electrical and Mechanical Characteristics

Description	Specification / Value
Interface connector	D-Sub, 9-pin, male
D-Sub male or female (PU connection)	Class 2
D-Sub male reversed version	Class 3
Cable termination	2 x horizontal, 2 x vertical, MAX: 2 x axial 1 cable outlet can be sealed with blanking plate
Cable diameter	4.5 mm (0.177") - 8.0 mm (0.315")
Cross section of individual conductor	Screw terminal: solid max. 1.5 mm <sup>2</sup> ; stranded max. 1.0 mm <sup>2</sup> IDC terminal: solid ø 0.64 mm Cage-clamp terminal: 0.08 - 0.5 mm <sup>2</sup> (0.75 mm <sup>2</sup> )
Termination type	Screw terminal, IDC terminal, cage-clamp terminal
Data transmission rate	According to bus specification, 12 MBit/s
Temperature range	-20 °C - +70 °C
Permissible humidity	Max. 75 % at + 25 °C, non-condensing
Protection class	IP 40, MAX: IP 30
Housing material	Thermoplast UL94V-1, MAX: ZnAl, galvanized
D-Sub screw	#4/40 UNC, knurled with cross-head
UL approval	UL E84703*
CE marking	ERbic connectors are passive components and do not need to be identified with the CE marking according to EU directives.

\* Due to continuous advancement, it is possible that the UL approval of a new version may not have been completed at the time of going to press.

## Pin Configuration

Terminal	D-Sub Pin	Signal
B (1)	3	RxD/TxD-P
A (2)	8	RxD/TxD-N
B (3)	3	RxD/TxD-P
A (4)	8	RxD/TxD-N
-	5	GND
-	6	VP (+5V)

# ERBIC PROFIBUS

## Ordering Information

ERbic Type	Color	Cable outlet	D-Sub 9-pin	Screw	Preferred <sup>1)</sup>	Part Number
<b>Profibus with external switch and IDC terminal</b>						
Profibus standard	slat gray	horizontal	Male	#4/40 UNC	Yes	144037
Profibus reversed	slat gray	horizontal	Male	#4/40 UNC	Yes	144176
Profibus with service/PU connection	slat gray	horizontal	Male and Female (PU connection)	#4/40 UNC	Yes	144536
Profibus Standard	slat gray	horizontal	male	#4/40 UNC		174281
Profibus with service / PU connection	slat gray	horizontal	male and female (PU connection)	#4/40 UNC		174283
Profibus reversed	slat gray	horizontal	male	#4/40 UNC		174286
<b>Profibus with external switch and cage clamp</b>						
Profibus with service/PU connection	slat gray	horizontal	Male	#4/40 UNC	Yes	174049
Profibus with external switch and cage clamp	slat gray	horizontal	male	#4/40 UNC		154558
<b>Profibus with external switch, IDC terminal and metal housing</b>						
Profibus MAX standard	silver	axial	Male	#4/40 UNC	Yes	134928
Profibus MAX Standard	silver	axial	male	#4/40 UNC		174282
<b>Profibus with external switch, screw terminal and metal housing</b>						
Profibus MAX Standard	silver	axial	male	#4/40 UNC	yes	204222
<b>Profibus with external switch and screw terminal</b>						
Profibus standard	slat gray	horizontal	Male	#4/40 UNC	Yes	134728
Profibus with service/PU connection	slat gray	horizontal	Male and Female (PU connection)	#4/40 UNC	Yes	144475
Profibus with service / PU connection	licht grau	horizontal	male and female (PU connection)	#4/40 UNC		134522
Profibus Standard	gray	horizontal	male	#4/40 UNC		154610
Profibus Standard	slat gray	horizontal	male	#4/40 UNC		174400
<b>Profibus node with screw terminal</b>						
Profibus standard	slat gray	horizontal	Male	#4/40 UNC	Yes	103648
Profibus with service/PU connection	slat gray	horizontal	Male and Female (PU connection)	#4/40 UNC	Yes	103663
Profibus standard	slat gray	vertical	Male	#4/40 UNC	Yes	103658
Profibus with service / PU connection	slat gray	horizontal	male	#4/40 UNC		124072
<b>Profibus termination with screw terminal</b>						
Profibus standard	yellow	horizontal	Male	#4/40 UNC	Yes	103649
Profibus with service/PU connection	yellow	horizontal	Male and Female (PU connection)	#4/40 UNC	Yes	104329
Profibus standard	yellow	vertical	Male	#4/40 UNC	Yes	103659
Profibus Standard	yellow	horizontal	male	#4/40 UNC		104445
Profibus Standard	rot	vertical	male	#4/40 UNC		104471
Profibus Standard	yellow	horizontal	male	#4/40 UNC		124069

Packaging: Single box with enclosed assembly instructions.

1) Preferred types are generally available from stock.

# ERBIC CAN BUS

The CAN bus, originally developed for automobile engine management, is distinguished by its particularly high reliability. Among other things, this necessitates a more complicated protocol, which leads to lower data rates and cable lengths. This can be compensated for in part by larger cable cross sections. Data rates reach 1 Mbit/s. The 9-pin D-Sub connector is standardized as the interface to the device. In some cases, a version with a shield coupling capacitor is available as an option (cable shield <-> housing D-Sub).



## Electrical and Mechanical Characteristics

Description	Specification / Value
Interface connector	D-Sub, 9-pin, female
D-Sub female or male (PU connection)	Class 2
D-Sub female reversed version	Class 3
Cable termination	2 x horizontal, 2 x vertical, MAX: 2 x axial 1 cable outlet can be sealed with blanking plate
Cable diameter	4.5 mm (0.177") - 8.0 mm (0.315")
Cross section of individual conductor	Screw terminal: 0.14 - 0.5 mm <sup>2</sup> ; HLG: 1.5 mm <sup>2</sup> MAX: 0.14 - 1 mm <sup>2</sup> (HLG) Cage-clamp terminal: 0.08 - 0.5 mm <sup>2</sup> (0.75 mm <sup>2</sup> ) (HLG)
Termination type	Screw terminal, cage-clamp terminal
Data transmission rate	According to CAN specification, max. 1 Mbit/s
Temperature range	-20 °C - +70 °C
Permissible humidity	Max. 75 % at + 25 °C, non-condensing
Protection class	IP 40 MAX: IP 30
Housing material	Thermoplast UL94V-1 MAX: ZnAl, galvanized
D-Sub screw	#4/40 UNC, knurled with cross-head
UL approval	UL E84703*
CE marking	ERbic connectors are passive components and do not need to be identified with the CE marking according to EU directives.

\* Due to continuous advancement, it is possible that the UL approval of a new version may not have been completed at the time of going to press.

# ERBIC CAN BUS

## Pin Configuration

Terminal	D-Sub Pin	Signal
1,6	3	CAN-GND
2,4	2	CAN-L
3,5	7	CAN-H
-	5	CAN-SHLD

## Pin Configuration (no HLG-Version)

Terminal	D-Sub Pin	Signal
1,9	9	V+
2,1	6	V+ GND
3,8	3	CAN-GND
4,6	2	CAN-L
5,7	7	CAN-H
-	5	CAN-SHLD

## Ordering Information

ERbic Type	Color	Cable outlet	D-Sub 9-pin	Screw	Preferred <sup>1)</sup>	Part Number
<b>CAN Bus with external switch and cage clamp</b>						
CAN Bus with shield decoupling capacitor HLG*	anthracit	horizontal	Female	#4/40 UNC	Yes	144744
CAN Bus with shield decoupling capacitor and service/PU connection HLG*	anthracit	horizontal	Female and Male (PU connection)	#4/40 UNC	Yes	154826
<b>CAN Bus with external switch and screw terminal</b>						
CAN Bus Standard HLG*	anthracit	vertical	Female	#4/40 UNC	Yes	154824
<b>CAN Bus with external switch, screw terminal and metal housing</b>						
CAN Bus MAX Standard HLG*	silver	axial	Female	#4/40 UNC	Yes	154039
<b>CAN Bus node with screw terminal</b>						
CAN Bus Standard	anthracit	horizontal	Female	#4/40 UNC	Yes	103668
CAN Bus with service/PU connection	anthracit	horizontal	Female and Male (PU connection)	#4/40 UNC		134149
CAN Bus with shield decoupling capacitor	anthracit	horizontal	Female	#4/40 UNC		103642
CAN Bus with shield decoupling capacitor, reversed	anthracit	horizontal	Female	#4/40 UNC		104320
CAN Bus Standard	anthracit	vertical	Female	#4/40 UNC		103669
CAN Bus Standard	anthracit	horizontal	female	#4/40 UNC	yes	124075
CAN Bus Standard	anthracit	vertical	female	#4/40 UNC		124076
<b>CAN Bus termination with screw terminal</b>						
CAN Bus Standard	green	horizontal	Female	#4/40 UNC	Yes	103643
CAN Bus Standard	green	vertical	female	#4/40 UNC		124079

\*HLG, only CAN High, CAN Low and CAN Ground can be connected.

Packaging: Single box with enclosed assembly instructions.

1) Preferred types are generally available from stock.

# ERbic - REDESIGN PROFIBUS

ERNI has continuously expanded its established line of Profibus, CAN bus and SafetyBus field bus connectors. The Profibus switch versions, with or without a programming interface, have now been redesigned.

With the new ERbic versions for Profibus, the external dimension has been reduced and the connector now fits into even smaller housing cut outs. The enclosed parts from the earlier version have now been fixed mounted. Furthermore, optional cable clamps are available for different cable diameters (from 6 to 9 mm). Beyond that, the new ERNI D-Sub connectors are also being used.

Well-established cable connection techniques are available to meet the specific requirements, such as: IDC terminal ("fast connection", which replaces the dismantling of the bus wires), cageclamp terminal and screw terminal block. In addition, the bus connector can be imprinted using the standard ID plate.

The variable connection techniques and cable strain relief provide customers with greatest possible flexibility when connecting the connector in the field. Profibus version in particular are designed for data rates up to 12 Mbit/s in applications which require moderate industry environments (IP20).

## Features

- The ERbic connector without PU corresponds to the requirements of the S7-300 PLC
- Available with programming interface
- All versions with switches (switch-in matching resistor)
- Profibus versions are delivered with ID plate and cable clamp suitable for an overall cable diameter of 8 mm



## Recommended Cables

Siemens:

- Profibus FC standard cable 6XV1830 - 0EN20
- Profibus FC robust cable 6XV1830 - 0JH10
- Profibus FC food cable 6XV1830 - 0GH10

LAPP cable:

- UNITRONIC FC 7-wire UL/CSA 2170826
- UNITRONIC L2/FIP UL/CSA 2170219

## Pin Configuration

Terminal	D-Sub Pin	Signal
B (1)	3	RxD/TxD-P
A (2)	8	RxD/TxD-N
B (3)	3	RxD/TxD-P
A (4)	8	RxD/TxD-N
-	5	GND
-	6	VP (+5 V)

# ERBIC - REDESIGN PROFIBUS

## Dimensional Drawing

Profibus without PU connection

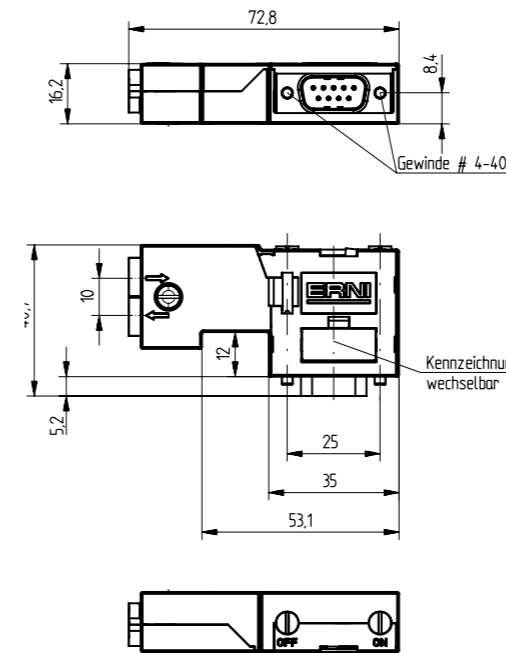

Profibus with PU connection

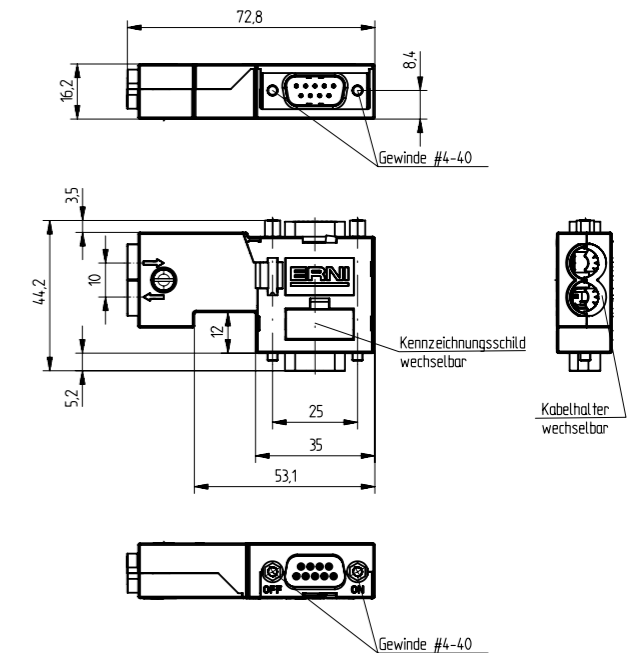

All dimensions in mm

## Ordering Information

ERbic Type with Switch	D-Sub 9-pin	Termination	Part Number
Profibus without service/PU connection	male	cage clamp	366311
Profibus with service/PU connection	male and female (PU connection)	cage clamp	366316
Profibus without service/PU connection	male	IDC terminal	366318
Profibus with service/PU connection	male and female (PU connection)	IDC terminal	366321
Profibus without service/PU connection	male	screw terminal	366323
Profibus with service/PU connection	male and female (PU connection)	screw terminal	366326

Packaging: Single box with enclosed assembly instruction, cable clamp (cable diameter 8 mm) and ID plate. All parts are pre-assembled.

Accessory	Cable Diameter	Color	Part Number
Cable clamp	6 mm	light grey	224427
Cable clamp	7 mm	light grey	224429
Cable clamp	9 mm	light grey	224433
ID plate	-	white	134577

# ERbic - REDESIGN CANBUS

## Features

- All parts are pre-assembled, only 1 mounting screw
- Extremely flexible due to:
  - Spring clamp terminal
  - Changeable cable clamps for different cable diameters from 6 to 9 mm (8 mm pre-assembled, 7 mm enclosed)
- Externally connectable termination resistor
- Optional diagnostic-interface
- Extra metallic stamped shield connection for excellent shield contact
- Processible with only one tool (screwdriver)
- Exchangeable ID plate for manual or automatic labeling
- Due to the red lever the switch setting is well visible
- Compact design
- Large area for customer-specific labeling, neutral version or with custom company-logo



## Recommended Cables

LAPP cables (for standard cable clamp 8 mm):

- UNITRONIC BUS CAN UL/CSA 2170266 ø 7.5 mm
- UNITRONIC BUS FD P CAN UL/CSA 2170278 ø 8.0 mm

Helu cables (for cable clamp 7 mm):

- CAN Bus cable 800571 ø 7.0 mm
- CAN Bus cable, high flexible 802182 ø 6.9 mm

## Technical Data

Description	Specification / Value
Interface connector	D-Sub, female class 2
PU connection	D-Sub, male class 2
Cable termination	2 x horizontal cable outlets can be covered by blind plate
Cable diameter	6 - 9 mm
Cross section of cage clamp	0.08 - 0.5 mm <sup>2</sup> (0.75 mm <sup>2</sup> )
Data transmission rate	max. 1 MBit/s (CAN-Spezifikation)
Temperature range	-20 °C to +70 °C
Permissible humidity	max. 75% at +25 °C, non-condensing
Protection class	IP 20
Housing material	Thermoplast UL94V-1
D-Sub screw 4/4 UNC	slotted head screw
UL approval	UL E84703
CE marking	ERbic connectors are passive components and do not need to be identified with CE marking acc. to EU directives.

# ERBIC - REDESIGN CANBUS

Version: only CAN-Signal

## Dimensional Drawings

CANbus without PU connection

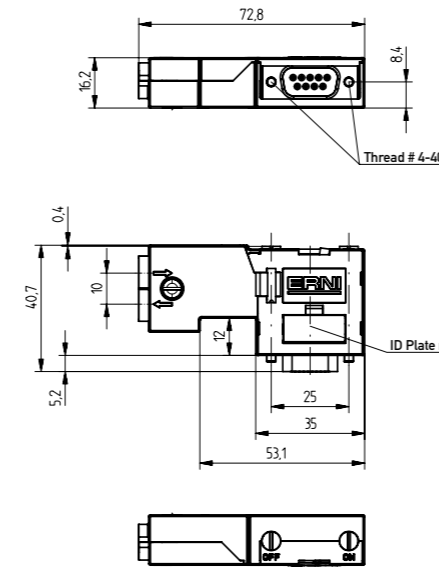

CANbus with PU connection

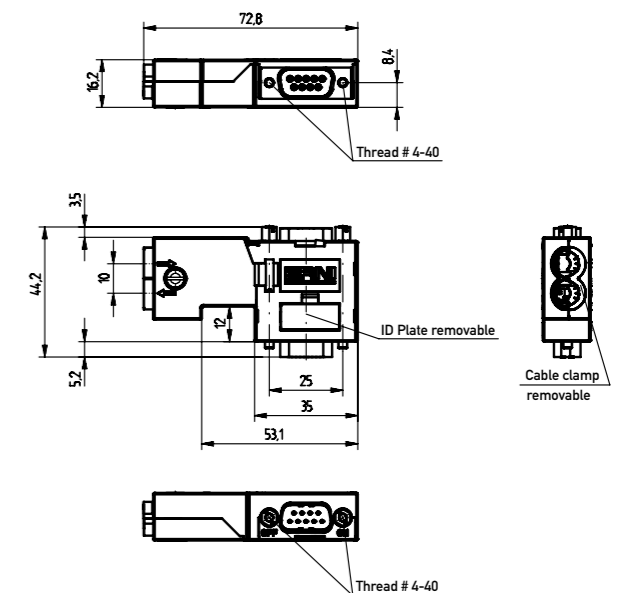

All dimensions in mm

## Pin Configuration

Terminal	D-Sub Pin	Wire color	Signal
GND	3	shielding	CAN Ground
C-L	2	white	CAN-Low
C-H	7	brown	CAN-High
C-L	2	white	CAN-Low
C-H	7	brown	CAN-High
GND	3	shielding	CAN Ground

## Ordering Information

Configuration	D-Sub 9-pin	Color	Termination	Part Number
CANbus without Service/PU connection	female	black	cage clamp	366328
CANbus with Service/PU connection	female and male (PU connection)	black	cage clamp	366331

Single box packaging:

- ERbic with pre-mounted cable clamp 8 mm
- installation instructions
- additional cable clamp 7 mm
- blind plate for unused cable outlets



# ERBIC - REDESIGN CANBUS

Version: CAN-Signal and Additional Voltage Feed

## Dimensional Drawings

CANbus without PU connection

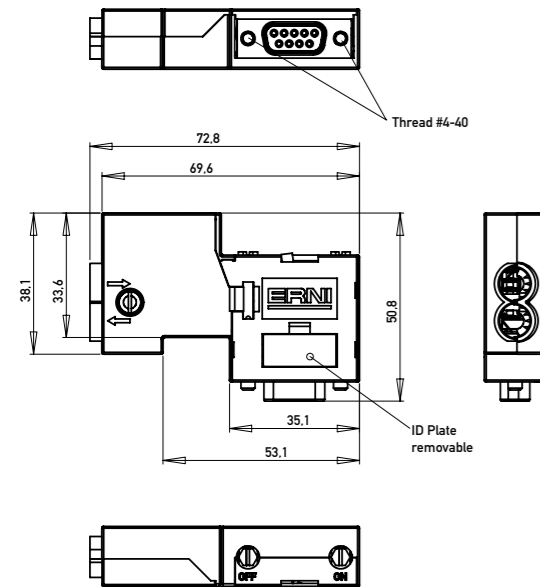

CANbus with PU connection

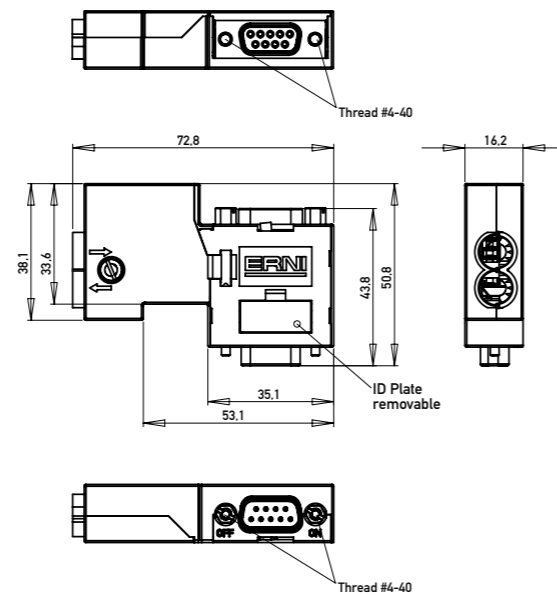

All dimensions in mm

## Pin Configuration

Terminal	D-Sub Pin	Wire color	Signal
V+	9		V+
V-	6		V-
GND	3	shielding	CAN Ground
C-L	2	white	CAN-Low
C-H	7	brown	CAN-High
C-L	2	white	CAN-Low
C-H	7	brown	CAN-High
GND	3	shielding	CAN Ground
V+	9		V+
V-	6		V-

## Ordering Information

Configuration	D-Sub 9-pin	Color	Termination	Part Number
CANbus without Service/PU connection	female	black	screw terminal	366343
CANbus with Service/PU connection	female and male (PU connection)	black	screw terminal	366346

Single box packaging:

- ERbic with pre-mounted cable clamp 8 mm
- installation instructions
- additional cable clamp 7 mm
- blind plate for unused cable outlets

# ERBIC - REDESIGN CANBUS ACCESSORIES

## Ordering Information

Configuration	Cable diameter	Color	Part Number
Cable clamp	6 mm	light gray	224427
Cable clamp	9 mm	light gray	224433
ID plate		white	134577

Single box packaging:

- ERbic with pre-mounted cable clamp 8 mm
- installation instructions
- additional cable clamp 7 mm
- blind plate for unused cable outlets

---

## Connect With Us

We make it easy to connect with our experts and are ready to provide the support you need. Visit [www.te.com/support](http://www.te.com/support) to chat with a Product Information Specialist.

---

### te.com

2023 TE Connectivity. All Rights Reserved.

TE Connectivity, TE connectivity (logo) ERNI, ERbic and Every Connection Counts are trademarks owned or licensed by the TE Connectivity family of companies. All other logos, products and/or company names referred to herein might be trademarks of their respective owners.

The information given herein, including drawings, illustrations and schematics which are intended for illustration purposes only, is believed to be reliable. However, TE Connectivity makes no warranties as to its accuracy or completeness and disclaims any liability in connection with its use. TE Connectivity's obligations shall only be as set forth in TE Connectivity's Standard Terms and Conditions of Sale for this product and in no case will TE Connectivity be liable for any incidental, indirect or consequential damages arising out of the sale, resale, use or misuse of the product. Users of TE Connectivity products should make their own evaluation to determine the suitability of each such product for the specific application.

074441 01/23 Original

### CATALOG

TE Connectivity

ERNI Electronics GmbH & Co. KG  
Seestraße 9  
73099 Adelberg  
Germany

Tel +49 7166 50-0  
[www.te.com](http://www.te.com)  
[www.erni.com](http://www.erni.com)