

Ansicht ohne Ansaughaube/  
view without hood

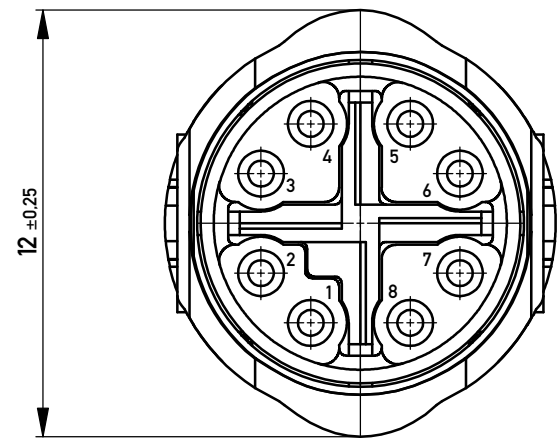

Koplanarität aller Kontakte <=0,1 mm  
Coplanarity of all contacts <=0,1mm  
Fehlende Maße und Angaben siehe DIN EN 61076-2-109  
Missing information and dimensions per DIN EN 61076-2-109

- SPC-Maß: Prüfmaße der Kategorie /1  
 /1 Für SPC-Maße muss eine x/s Regelkarte geführt werden mit Nachweis der Prozessfähigkeit in der Serie (Cpk) oder 100% - Prüfungen
- Prüfmaß: Prüfmaße der Kategorie /2 und /3  
 /2 Für Prüfmaße muss eine x/s Regelkarte geführt werden
- /3 Prüfmaße werden serienbegleitend attributiv (i.O. / n.i.O.) geprüft

Copyright by ERNI Product GmbH & Co. KG  
Proprietary notice pursuant to ISO 16016 to be observed.

Information:		Tolerances	Scale 5:1	Gurtverp. / tape and reel	
All rights reserved. Only for Information. To ensure that this is the latest version of this drawing, please contact one of the ERNI companies before using.		All Dimensions in mm	Type M12 8 Pol CAT6A SMD		Bemerkung
Subject to modification without prior notice. Drawing will not be updated.		Designation		Federleiste M12 8 Pol CAT6A SMD / THR	
www.ERNI.com		394812		I A3	
g	25.01.2017	Class M12			
Index	Date				