

E197851 86 [06]

12.5 x 7.5 x 10.0 mm

## Features

- Low coil power consumption
- High sensitivity
- Conforms to FCC part 68
- PC board mounting
- Small size, light weight



## Contact Data\*

Contact Arrangement	1C = SPDT
Contact Rating	2A @ 120VAC, Resistive 2A @ 24VDC, Resistive

Contact Resistance	< 50 milliohms initial
Contact Material	Ag + Au
Maximum Switching Power	30W
Maximum Switching Voltage	125VAC, 60VDC
Maximum Switching Current	2A

## Coil Data\*

Coil Voltage VDC		Coil Resistance $\Omega$ +/- 10%		Pick Up Voltage VDC (max)	Release Voltage VDC (min)	Coil Power W	Operate Time ms	Release Time ms
Rated	Max	.15W	.20W	75% of rated voltage	10% of rated voltage			
3	3.9	60	45	2.25	.3	.15 .20	4.5	1.5
5	6.5	167	125	3.75	.5			
6	7.8	240	180	4.50	.6			
9	11.7	540	405	6.75	.9			
12	15.6	960	720	9.00	1.2			
24	31.2	3840	2880	18.00	2.4			

## General Data\*

Electrical Life @ rated load	100K cycles, average
Mechanical Life	5M cycles, min.
Insulation Resistance	100M $\Omega$ min. @ 500VDC initial
Dielectric Strength, Coil to Contact	1500V rms min. @ sea level initial
Contact to Contact	1000V rms min. @ sea level initial
Shock Resistance	100m/s <sup>2</sup> for 11 ms
Vibration Resistance	3.30mm double amplitude 10~40Hz
Terminal (Copper Alloy) Strength	5N
Operating Temperature	-40°C to +85°C
Storage Temperature	-40°C to +155°C
Solderability	260°C for 5 s
Weight	2.2g

\* Values can change due to the switching frequency, desired reliability levels, environmental conditions and in-rush load levels. It is recommended to test actual load conditions for the application. It is the user's responsibility to determine the performance suitability for their specific application. The use of any coil voltage less than the rated coil voltage may compromise the operation of the relay.

### Ordering Information

1. Series	J103	1C	12VDC	.20	S
J103					
2. Contact Arrangement	1C = SPDT				
3. Coil Voltage					
3VDC					
5VDC					
6VDC					
9VDC					
12VDC					
24VDC					
4. Coil Power					
.15 = .15W					
.20 = .20W					
5. Sealed					
S = Sealed (standard)					

### Dimensions

Units = mm

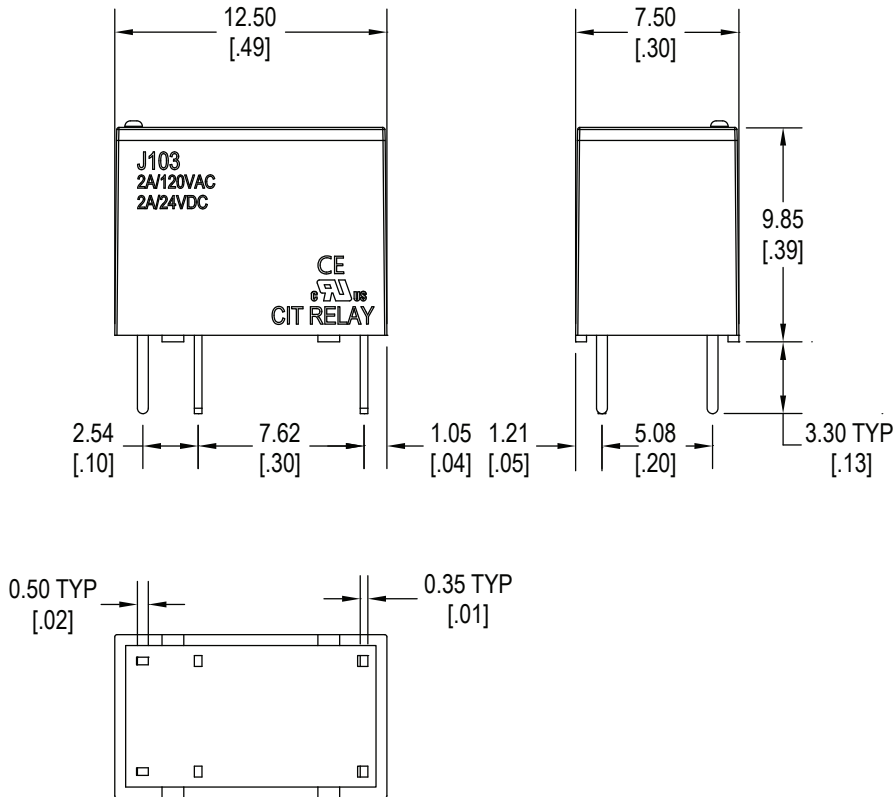

### Schematics & PC Layouts

Bottom Views

