

DC Brushless Motor Driver Series

3 Hall Sensors

Three-Phase Brushless Motor Pre-Driver

BM64300MUV

General Description

BM64300MUV is the pre-driver IC of sine wave drive for three-phase brushless motor driver that supports 48 V power supply controlling the motor driver constructed in external FETs. It detects a rotor position by 3 Hall sensors. In addition, silent and low vibration operations are implemented by making the output current a sine waveform.

Features

- Speed Control on PWM Duty Input
- External Output FET Nch+Nch
- Built-in Boost Voltage Circuit
- 3 Hall Sine Wave Drive
- Automatic Lead Angle Control
- Motor Pole Select Function
- Soft Start Function
- Dead Time Setting
- Current Limit Function
- Power Save Function
- Direction of Rotation Setting
- Short Brake Control
- Built-in Several Protection Functions (Motor Lock Protection [MLP], High Speed Rotation Protection, Over Voltage Lock Out [OVLO], Under Voltage Lock Out [UVLO], Thermal Shutdown [TSD], Over Current Protection [OCP])

Key Specifications

- Operating Supply Voltage Range : 28 V to 63 V
- Output PWM Frequency : 40 kHz (Typ)
- Standby Current : 1.2 mA (Typ)
- Operating Temperature Range : -40 °C to +105 °C

Package

VQFN040V6060

W (Typ) x D (Typ) x H (Max)

6.00 mm x 6.00 mm x 1.00 mm



Application

- Fan Motor
- Other General Consumer Equipment

Typical Application Circuit

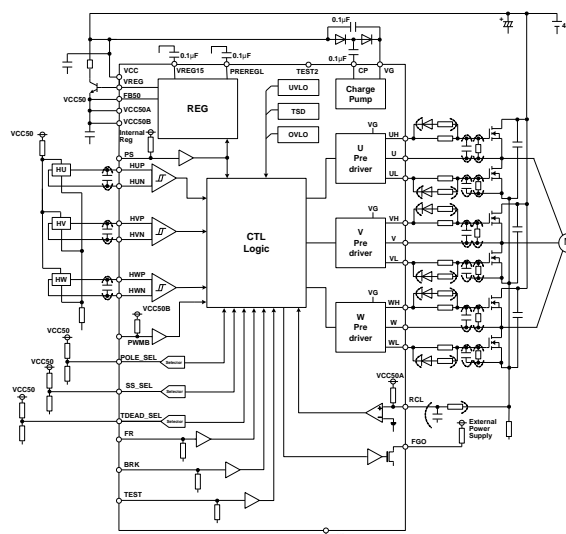

○Product structure : Silicon integrated circuit ○This product has no designed protection against radioactive rays

Contents

General Description	1
Features	1
Application.....	1
Typical Application Circuit.....	1
Key Specifications.....	1
Package	1
Contents.....	2
Pin Configurations.....	3
Pin Descriptions.....	4
Block Diagram	5
Absolute Maximum Ratings.....	6
Thermal Resistance	7
Recommended Operating Conditions	7
Electrical Characteristics	8
Application Example.....	10
Board Design Note.....	10
Description of Pin Functions	11
Description of Operations	14
Thermal Resistance Model.....	22
I/O Equivalence Circuits	23
Operational Notes.....	24
Ordering Information	26
Marking Diagram.....	26
Physical Dimension and Packing Information	27
Revision History.....	28

Pin Configurations

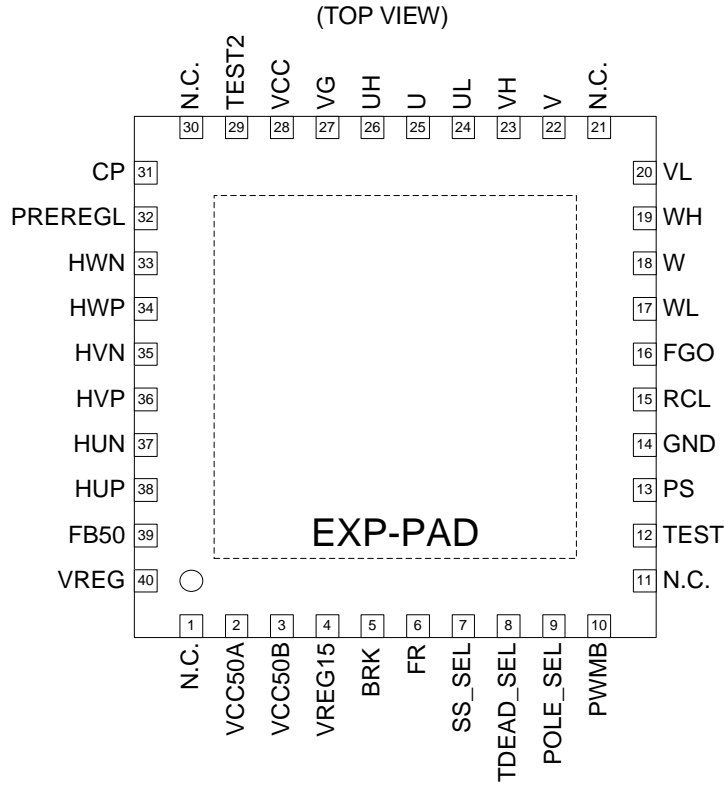

Pin Descriptions

Pin No.	Pin Name	Function	Pin No.	Pin Name	Function
1	N.C.	N.C. (Open)	21	N.C.	N.C. (Open)
2	VCC50A	Standard voltage input (to internal analog circuit)	22	V	V phase external FET output feedback input
3	VCC50B	Standard voltage input (to internal logic circuit)	23	VH	V phase High side pre-driver output
4	VREG15	Internal power supply output for logic circuit	24	UL	U phase Low side pre-driver output
5	BRK	Brake control	25	U	U phase external FET output feedback input
6	FR	Rotation direction setting	26	UH	U phase High side pre-driver output
7	SS_SEL	Soft Start setting	27	VG	Boost output
8	TDEAD_SEL	Dead Time setting	28	VCC	Power supply
9	POLE_SEL	Motor Pole setting	29	TEST2	TEST (Open)
10	PWMB	PWM input (negative logic)	30	N.C.	N.C. (Open)
11	N.C.	N.C. (Open)	31	CP	Capacitor connection for boost
12	TEST	TEST (GND or Open)	32	PREREGL	Low side Pre-Driver standard voltage output
13	PS	Power Save input	33	HWN	W phase Hall input -
14	GND	Ground	34	HWP	W phase Hall input +
15	RCL	Output current detection voltage input	35	HVN	V phase Hall input -
16	FGO	Rotating speed pulse signal output	36	HVP	V phase Hall input +
17	WL	W phase Low side pre-driver output	37	HUN	U phase Hall input -
18	W	W phase external FET output feedback input	38	HUP	U phase Hall input +
19	WH	W phase High side pre-driver output	39	FB50	Standard voltage Feedback input
20	VL	V phase Low side pre-driver output	40	VREG	Standard voltage output
Back Side	EXP-PAD	Connect the EXP-PAD to the GND.			

Block Diagram

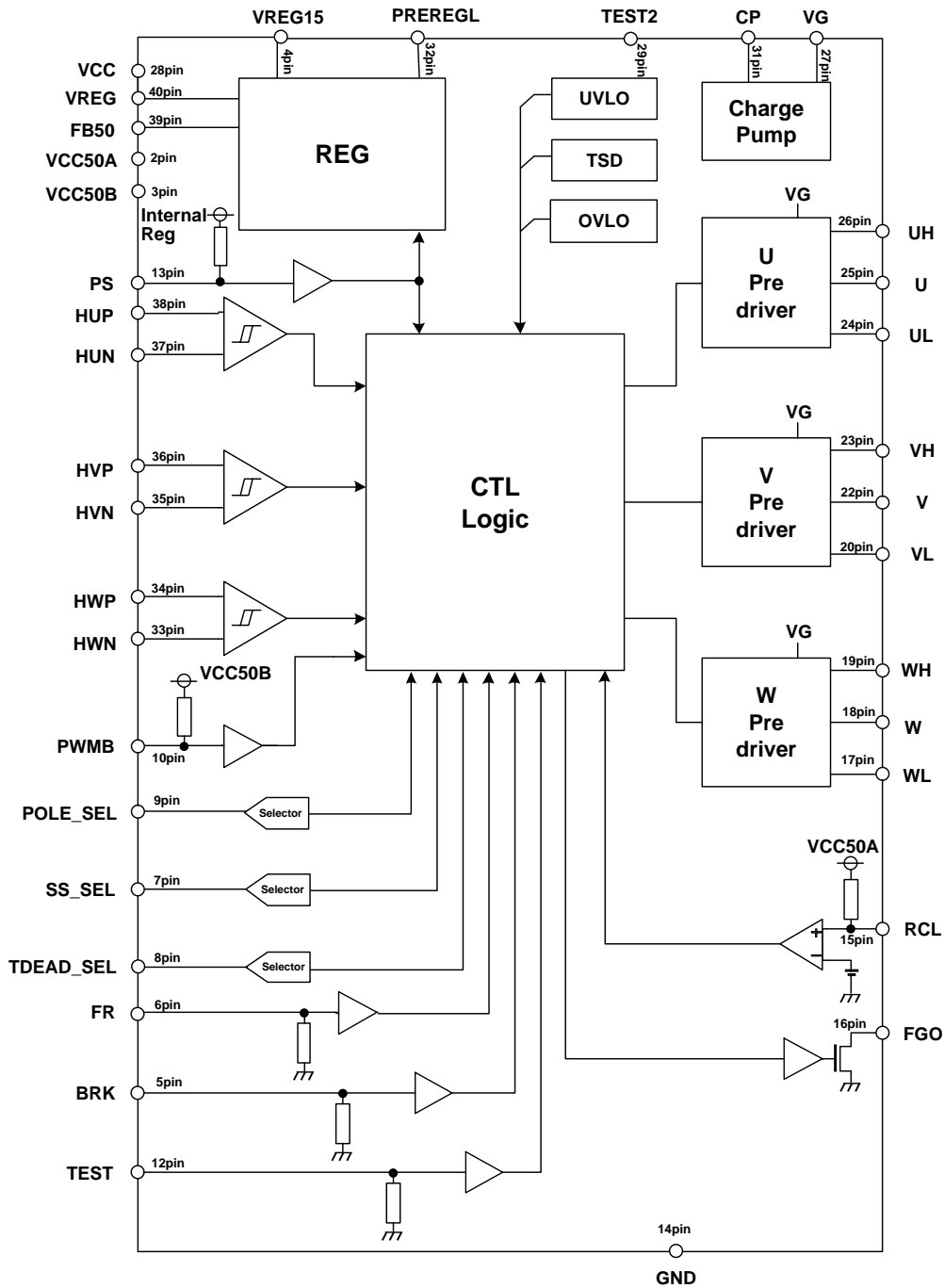

Absolute Maximum Ratings (Ta=25 °C)

Parameters	Symbol	Rating	Unit
Power Supply Voltage (VCC)	V _{CC}	100	V
VG Voltage	V _G	100	V
Pre-driver High Side Output Voltage (UH, VH, WH)	V _{OH}	100	V
Pre-driver Low Side Output Voltage (UL, VL, WL)	V _{OL}	20	V
Pre-driver Output-current (consecutive) (UH, VH, WH, UL, VL, WL)	I _{OMAX1}	±10	mA
Pre-driver Output-current ^(Note 1) (UH, VH, WH, UL, VL, WL)	I _{OMAX2}	±100	mA
External FET Output Feedback Voltage (U, V, W)	V _{FBI}	100	V
FGO Pin Voltage	V _{FGO}	30	V
FGO Pin Current	I _{FGO}	10	mA
VREG Pin Current	I _{VREG}	-15	mA
RCL Pin Voltage	V _{RCL}	4.5	V
Control Input Pin Voltage ^(Note 2)	V _{IN1}	7	V
Hall Input Pin Voltage ^(Note 3)	V _{IN2}	7	V
Maximum Junction Temperature	T _{jmax}	150	°C
Storage Temperature Range	T _{stg}	-55 to +150	°C

Caution 1: Operating the IC over the absolute maximum ratings may damage the IC. The damage can either be a short circuit between pins or an open circuit between pins and the internal circuitry. Therefore, it is important to consider circuit protection measures, such as adding a fuse, in case the IC is operated over the absolute maximum ratings.

Caution 2: Should by any chance the maximum junction temperature rating be exceeded the rise in temperature of the chip may result in deterioration of the properties of the chip. In case of exceeding this absolute maximum rating, design a PCB with thermal resistance taken into consideration by increasing board size and copper area so as not to exceed the maximum junction temperature rating.

(Note 1) Pulse Width ≤ 1 μs, Pulse Duty ≤ 10 %.

(Note 2) The TDEAD_SEL, SS_SEL, POLE_SEL, PWMB, PS, BRK, FR, TEST pins.

(Note 3) The HUP, HUN, HVP, HVN, HWP, HWN pins.

Thermal Resistance^(Note 4)

Parameter	Symbol	Thermal Resistance (Typ)		Unit
		1s ^(Note 6)	2s2p ^(Note 7)	
VQFN040V6060				
Junction to Ambient	θ_{JA}	101.4	23.7	°C/W
Junction to Top Characterization Parameter ^(Note 5)	Ψ_{JT}	5.0	3.0	°C/W

(Note 4) Based on JEDEC51-2A (Still-Air)

(Note 5) The thermal characterization parameter to report the difference between junction temperature and the temperature at the top center of the outside surface of the component package.

(Note 6) Using a PCB board based on JEDEC51-3.

(Note 7) Using a PCB board based on JEDEC51-5, 7.

Layer Number of Measurement Board	Material	Board Size
Single	FR-4	114.3 mm x 76.2 mm x 1.57 mmt

Top	
Copper Pattern	Thickness
Footprints and Traces	70 μ m

Layer Number of Measurement Board	Material	Board Size	Thermal Via ^(Note 8)	
			Pitch	Diameter
4 Layers	FR-4	114.3 mm x 76.2 mm x 1.6 mmt	1.20 mm	Φ 0.30 mm

Top		2 Internal Layers		Bottom	
Copper Pattern	Thickness	Copper Pattern	Thickness	Copper Pattern	Thickness
Footprints and Traces	70 μ m	74.2 mm x 74.2 mm	35 μ m	74.2 mm x 74.2 mm	70 μ m

(Note 8) This thermal via connects with the copper pattern of all layers.

Recommended Operating Conditions

Parameters	Symbol	Min	Typ	Max	Unit
Operation Temperature	Topr	-40	+25	+105	°C
Operating Supply Voltage (VCC)	V _{CC}	28.0	48.0	63.0	V
Control Input Pin Voltage ^(Note 9)	V _{IN1}	0	-	V _{VCC50}	V

(Note 9) The TDEAD_SEL, SS_SEL, POLE_SEL, PWMB, BRK, FR, TEST pins.

Electrical Characteristics (Unless otherwise specified V_{CC}=48 V Ta=25 °C)

Parameters	Symbol	Min	Typ	Max	Unit	Conditions
<Whole>						
Circuit Current ^(Note 10)	I _{CC}	-	13	20	mA	PS=0 V
Standby Current ^(Note 10)	I _{STBY}	-	1.2	1.8	mA	PS=5 V
VCC50 Voltage	V _{VCC50}	4.5	5.0	5.5	V	
VREG15 Voltage	V _{VREG15}	1.35	1.50	1.65	V	
<Boost Circuit>						
VG Voltage	V _G	V _{CC} +6.5	V _{CC} +9.5	V _{CC} +12.5	V	
<Pre-driver Output>						
High Side Output High Voltage	V _{OHH}	V _G -0.3	V _G -0.1	V _G	V	I _O =-5 mA
High Side Output Low Voltage	V _{OHL}	0	0.1	0.3	V	I _O =+5 mA
Low Side Output High Voltage	V _{OLH}	6.2	9.4	12.5	V	I _O =-5 mA
Low Side Output Low Voltage	V _{OLL}	0	0.1	0.3	V	I _O =+5 mA
Output PWM Frequency	f _{PWM}	36	40	44	kHz	
<Hall Input>						
Input Bias Current	I _{HALL}	-2.0	-0.1	+2.0	μA	HUP=0 V, HUN=0 V HVP=0 V, HVN=0 V HWP=0 V, HWN=0 V
Common Mode Input Voltage Range	V _{HALLCM}	0	-	V _{VCC50} -1.7	V	
Input Voltage Range	V _{HALLRNG}	0	-	V _{VCC50}	V	
Minimum Input Voltage	V _{HALLMIN}	50	-	-	mV _{P-P}	
Hall Input Hysteresis Level +	V _{HYS+}	2	12	22	mV	
Hall Input Hysteresis Level -	V _{HYS-}	-22	-12	-2	mV	
<PS>						
Input Current	I _{PS}	-82.5	-55.0	-27.5	μA	PS=0 V
Input High Voltage	V _{STBY}	3.8	-	5.0	V	Power Save
Input Low Voltage	V _{ENA}	0	-	0.5	V	Drive
<FR>						
Input Current	I _{FR}	25	50	75	μA	FR=V _{VCC50}
Input High Voltage	V _{FRH}	V _{VCC50} -1.2	-	V _{VCC50}	V	U→V→W
Input Low Voltage	V _{FRL}	0	-	0.8	V	U→W→V
<BRK>						
Input Current	I _{BRK}	25	50	75	μA	BRK=V _{VCC50}
Input High Voltage	V _{BRKH}	V _{VCC50} -1.2	-	V _{VCC50}	V	Short brake
Input Low Voltage	V _{BRKL}	0	-	0.8	V	Drive

For parameters involving current, positive notation means inflow of current to the IC while negative notation means outflow of current from the IC.
(Note 10) Total value of VCC, VCC50A and VCC50B circuit current.

Electrical Characteristics – Continued (Unless otherwise specified $V_{CC}=48\text{ V}$ $T_a=25\text{ }^\circ\text{C}$)

Parameters	Symbol	Min	Typ	Max	Unit	Conditions
<Control Input: SS_SEL, POLE_SEL, TDEAD_SEL>						
Input Current	I_{IN}	-1.2	-	+1.2	μA	
<Speed Control Input: PWMB>						
Input Current	I_{PWMB}	-75	-50	-25	μA	PWMB=0 V
Input High Voltage	V_{PWMBH}	$V_{VCC50}-1.2$	-	V_{VCC50}	V	
Input Low Voltage	V_{PWMBL}	0	-	0.8	V	
Input Frequency Range	f_{PWMB}	1	-	50	kHz	
<FGO Output>						
Output Low Voltage	V_{FGOL}	0	0.1	0.3	V	$I_{FGO}=+3\text{ mA}$
Output Leak Current	I_{FGLEAK}	-	-	1	μA	FGO=30 V
<Current limit: RCL>						
Input Current	I_{RCL}	-35	-20	-10	μA	RCL=0 V
Current Limit Detect Voltage	V_{CL}	0.18	0.20	0.22	V	
<UVLO>						
VCC UVLO Release Voltage	V_{UVH}	18	20	22	V	
VCC UVLO Lockout Voltage	V_{UVL}	16	18	20	V	
VG UVLO Voltage	V_{UVVG}	$V_{CC}+2.0$	$V_{CC}+3.0$	$V_{CC}+4.0$	V	
<OVLO>						
OVLO Release Voltage	V_{OVL}	65	69	73	V	
OVLO Lockout Voltage	V_{OVH}	68	72	76	V	
<Motor Lock Protection, Several Protections>						
Motor Lock Protection Detect Time	t_{LK_DET}	0.45	0.50	0.55	s	
Protect Time	t_{LK_PRT}	4.5	5.0	5.5	s	Several Protections ^(Note 11)

For parameters involving current, positive notation means inflow of current to the IC while negative notation means outflow of current from the IC.

(Note 11) Motor Lock Protection (MLP), High Speed Rotation Protection, Over Voltage Lock Out (OVLO), Thermal Shutdown (TSD), Over Current Protection (OCP).

Application Example

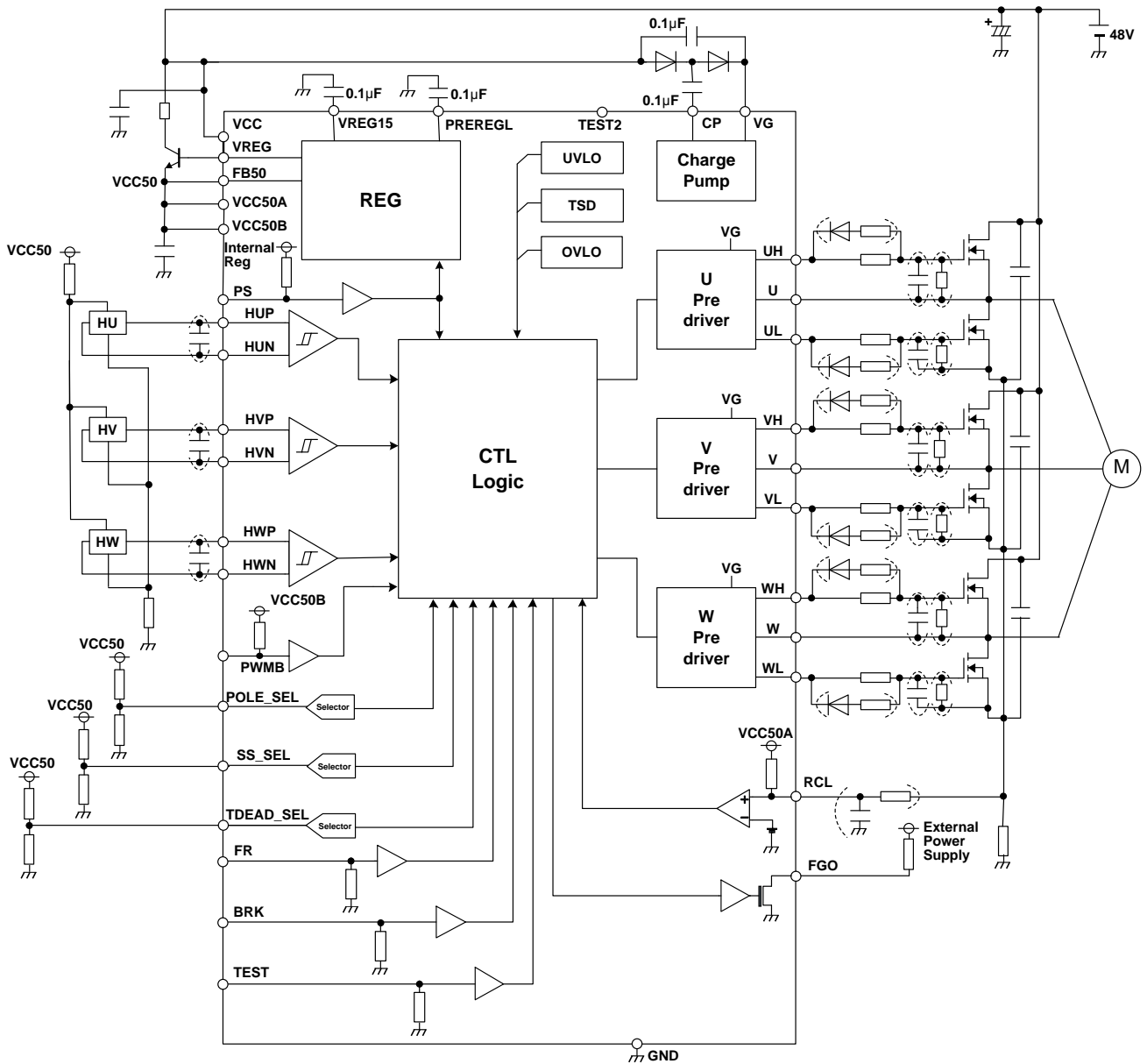

Board Design Note

1. The IC power supply, the IC ground, the motor outputs and the motor ground lines are made as wide as possible.
2. The IC ground is arranged to the ground connector of PCB as close as possible.
3. The bypass capacitors connected to the VCC pin and external FETs are placed as close as possible to the VCC pin and external FETs.

Description of Pin Functions

1. Power Supply Pin (VCC)
 - In order to decrease the AC impedance in wide frequency bandwidth, place a ceramic capacitor (0.01 μ F to 0.1 μ F) in parallel with the electrolytic capacitor.
 - The motor's Back EMF and PWM switching noise may affect the VCC pin voltage. To regulate or stabilize the V_{CC} voltage supply, place the bypass capacitor to the IC pin as close as possible. Increase the value of the bypass capacitor if the IC needs to drive higher current or if it is experiencing higher Back EMF. V_{CC} must not exceed the absolute maximum ratings. It is effective to add a zener diode not exceeding the absolute maximum ratings. Take note that reversing the voltages of the VCC and the GND may destroy the IC.
2. Ground Pin (GND)

The GND must have impedance as low as possible and must always be maintained as the lowest voltage potential. This is to reduce the noise caused by the switching current, and to make the internal standard voltages stable. Avoid having common impedance with other devices' GND line.
3. Boost Pins (CP, VG)

Built-in charge pump circuit (for High side external FET drive) generates boost voltage $V_G = V_{CC} + 9.5$ V (Typ) by connecting capacitors and diodes to the CP pin, the VCC pin and the VG pin. It is recommended to use capacitor 0.1 μ F or more. And it is recommended to use diode absolute maximum voltage 100 V or more, 1.0 A and reverse recovery time $t_{rr} \leq 100$ ns.
4. High Side Pre-driver Output Pins (UH, VH, WH)

The external FET high side gate drive voltage is $V_{CC} + 9.5$ V (Typ). Note that 500 k Ω (Typ) resistor is built between these pins (UH, VH, WH) and the FET output feedback pins (U, V, W) on each phase.
5. Low Side Pre-driver Output Pins (UL, VL, WL)

The external FET low side gate drive voltage is 9.5 V (Typ). Note that 200 k Ω (Typ) resistor is built between these pins (UL, VL, WL) and the GND on each phase.
6. External FET Output Feedback Input Pins (U, V, W)

Connect these pins to the source side of external High side FET. High side FET driver circuit generates High side pre-driver output voltage based on this pin. Do not leave this pin open, because the voltage higher than expected can be applied to the High side FET and cause destruction. Also, this pin can swing the GND potential or less under the influence of Back EMF by the motor, and cause malfunction or destruction if it reaches -2 V or less. Preventive measures, such as inserting schottky diodes to the GND, can avoid such unexpected IC destruction.
7. Regulator Input Pins (FB50, VCC50A, VCC50B) / Output Pins (VREG15, VREG)

The VREG15 pin is 1.5 V (Typ) for internal power supply output for logic circuit. And the VREG pin and the FB50 pin make VCC50 voltage (Standard voltage) 5 V (Typ) by connecting external NPN transistor. Refer to P. 21 for circuit configuration. the VCC50A pin is 5 V input to internal analog circuit. And the VCC50B pin is 5 V input to internal logic circuit. Connect both pins to VCC50 voltage. It is recommended to connect 0.1 μ F to 1 μ F capacitor to the VCC50A, VCC50B and VREG15 pins. And connect nothing to the VREG15 pin except a capacitor.
8. Power Save Pin (PS)

The PS pin controls ON/OFF state on each phase output (Negative logic).
The Power Save state has priority of turning off regulator output (VREG, VREG15) over other control input signals. Furthermore, the PS pin is pulled up to internal power supply by 101 k Ω (Typ) resistor.

Table 1. PS Pin Setting Table

PS pin Setting	Function
Low	Drive
High / Open	Power Save

9. Motor Pole Setting Pin (POLE_SEL)

Motor Pole can be set at the POLE_SEL pin by applying the appropriate voltage via resistive voltage dividers from VCC50 (5 V [Typ]). High accuracy is needed for setting, and it is recommended to use 5 % or less precision resistors. Refer to P. 19 regarding the Motor Pole setting method.

Description of Pin Functions – Continued

10. Soft Start Setting Pin (SS_SEL)
This IC sets Soft Start step time at the SS_SEL pin by applying the appropriate voltage via resistive voltage dividers from VCC50 (5 V [Typ]). High accuracy is needed for setting, and it is recommended to use 1 % or less precision resistors. Refer to P. 17 regarding the time setting method of Soft Start.
11. Dead Time Setting Pin (TDEAD_SEL)
Dead Time can be set at the TDEAD_SEL pin by applying the appropriate voltage via resistive voltage dividers from VCC50 (5 V [Typ]). High accuracy is needed for setting, and it is recommended to use 1 % or less precision resistors. Refer to P. 19 regarding the time setting method of Dead Time.
12. Speed Control PWM Input Pin (PWMB)
The PWM signal Duty for the PWMB pin can control motor speed (Negative logic). The PWMB pin is pulled up to VCC50B by 100 k Ω (Typ) resistor.
13. Hall Input Pins (HUP, HUN, HVP, HVN, HWP, HWN)
 - Hall comparator is designed with hysteresis (± 12 mV [Typ]) in order to prevent malfunction due to noise.
 - Case of Hall element: Set the bias current for the Hall element so that the amplitude of Hall input voltage is the minimum input voltage ($V_{HALLMIN}$) or more. It is recommended to connect a ceramic capacitor with about 100 pF to 0.01 μ F value between the differential input pins of the Hall comparator. Hall comparator has common mode input voltage range (V_{HALLCM}). Set the bias voltage within the V_{HALLCM} .
 - Case of Hall IC: Connect the HUP pin, the HVP pin and the HWP pin to each output of Hall ICs and input within the input voltage range ($V_{HALLRNG}$). If the output of the Hall IC is an open drain, pull up it to VCC50 voltage by external resistance. Input a reference voltage within V_{HALLCM} into the HUN pin, the HVN pin and the HWN pin (e.g., input a half voltage of VCC50 voltage).
14. Output Current Detect Pin (RCL)
The RCL pin is an input pin for the current limit comparator. Take into consideration the wiring pattern on the PCB to reduce noise when designing PCB layout. Note that the RCL pin is pulled up to VCC50A by 250 k Ω (Typ) resistor.
15. FG Output Pin (FGO)
The FGO pin outputs FG signal that is generated by Hall signal. No output in Power Save mode. The FGO pin is open drain output, so this pin must be pulled up to external voltage by 10 k Ω to 100 k Ω resistor. Note that FGO voltage and current should not exceed the maximum absolute ratings.
16. Rotation Direction Setting Pin (FR)
The FR pin controls rotational direction change. Phase driving sequence is U \rightarrow V \rightarrow W when FR=High, and U \rightarrow W \rightarrow V when FR=Low or Open. Changing the rotational direction during motor rotation is not recommended. If the rotational direction is changed, outputs will shift to short brake mode until the rotational speed becomes 500 rpm or less. The FR pin is pulled down by 100 k Ω (Typ) resistor.

Table 2. FR Pin Setting Table

FR pin Setting	Function
Low / Open	U \rightarrow W \rightarrow V
High	U \rightarrow V \rightarrow W

Description of Pin Functions – Continued

17. Brake Control Pin (BRK)

- The BRK pin can stop a rotation. It enters short brake mode with BRK=High, wherein all high side external FETs are turned off and all low side external FETs are turned on. It cancels short brake mode when BRK=Low or Open. The BRK pin is pulled down by 100 k Ω (Typ) resistor.
- Short brake has higher priority than other protection functions. That is why the protection function is cancelled and short brake operation is enabled when the short brake starts operation during other protection function is operating.

Table 3. BRK Pin Setting Table

BRK pin Setting	Function
Low / Open	Drive
High	Short Brake

18. Voltage Output for Low Side Pre-driver Pin (PREREGL)

The PREREGL pin is 9.5 V (Typ) for internal power supply output for low side pre-driver circuit. It is recommended to connect 0.1 μ F or more to the PREREGL pin. And connect nothing to the PREREGL pin except a capacitor.

19. Non Connection Pin (N.C.)

No electrical connection with IC internal circuit.

Description of Operations

1. Timing Chart

It detects the rotor position by 3 Hall sensors. In addition, silent and low vibration are implemented by making the output current a sine waveform.

1.1 Timing chart of the sine wave drive on 3 Hall sensors

The timing chart of the 3 Hall sensor signals and external FET output signals are shown below.

FR=High (U→V→W, lead angle 0°)

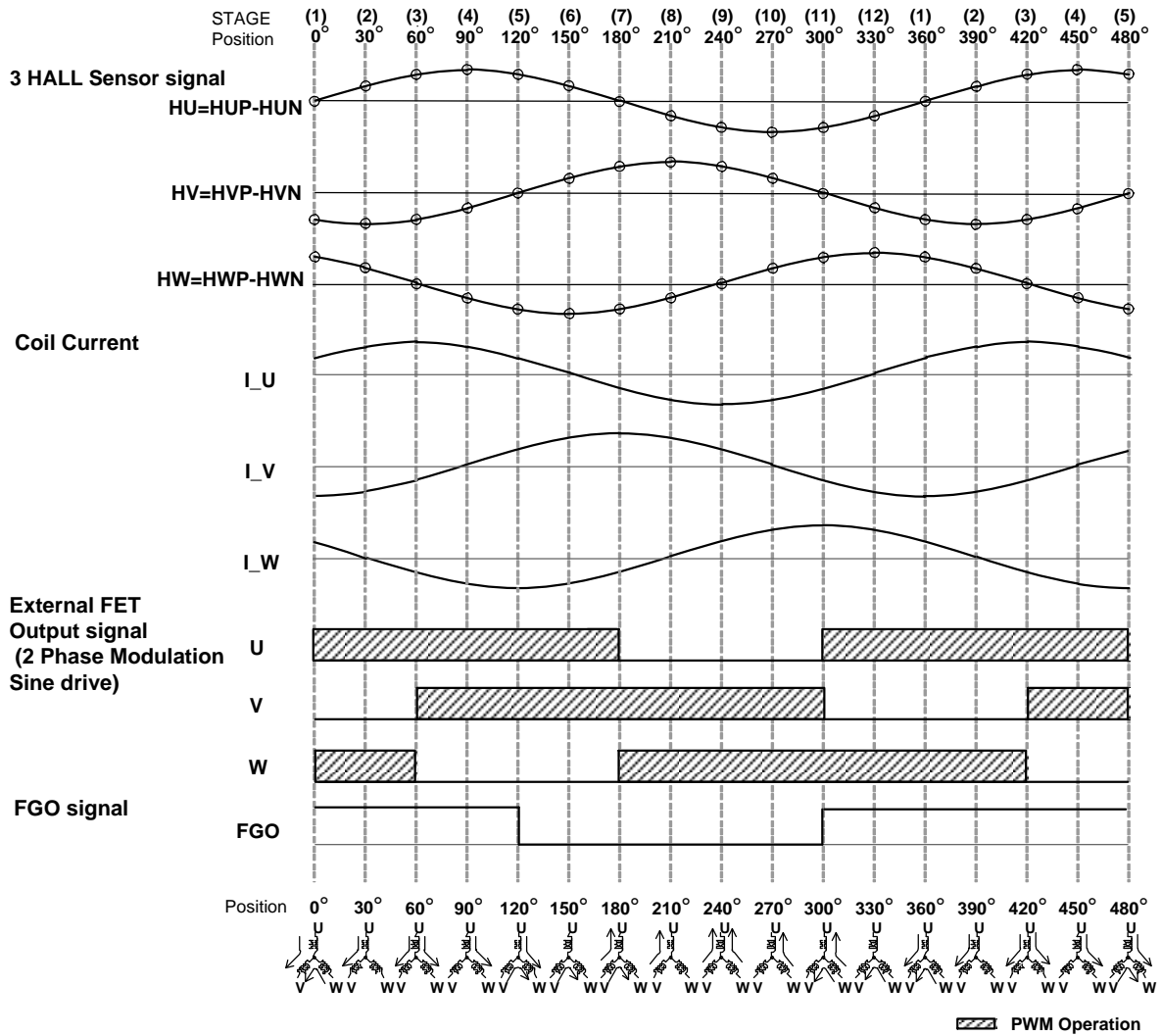

Figure 1. Timing Chart for Sine Wave Drive (FR=High)

1.1 Timing chart of the sine wave drive on 3 Hall sensors – Continued

FR=Low (U→W→V, lead angle 0°)

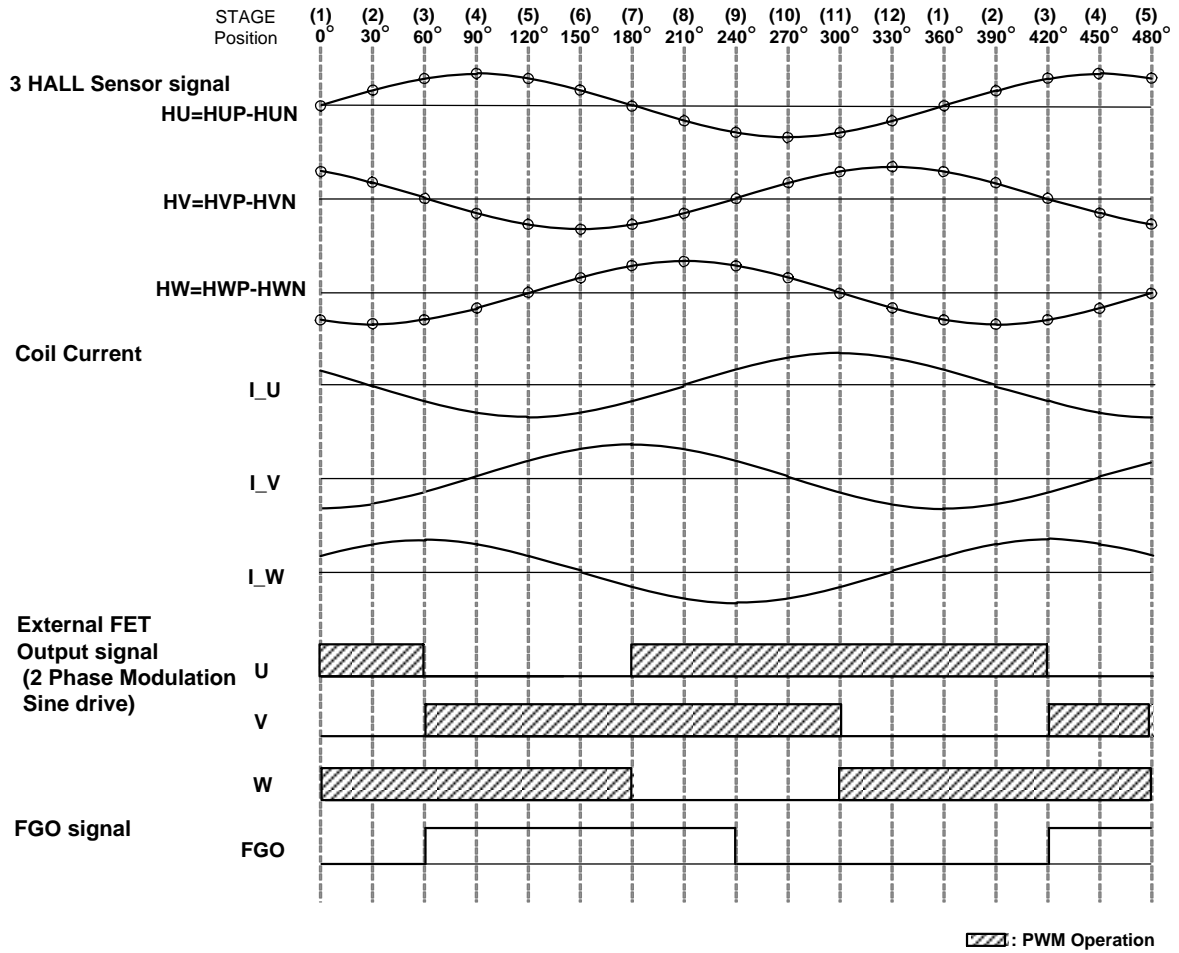

Figure 2. Timing Chart for Sine Wave Drive (FR=Low)

Adjustment of the Hall Sensor

When the Hall sensor is used, the amplitude adjustment of the Hall signal is important for a stable drive. It is necessary to detect the correct position of a motor that the amplitude of Hall signal is larger enough than the Hall input hysteresis level+ (V_{HYS+}) and Hall input hysteresis level- (V_{HYS-}). About Selections of Hall element or Hall IC, it is necessary to fully consider the sensitivity and temperature characteristics.

1. Timing Chart – Continued

1.2 Energizing Logic

FR=High (U→V→W, lead angle 0°)

Table 4. Energizing Logic Table

STAGE	Input Condition			Output State		
	HU =(HUP)-(HUN)	HV =(HVP)-(HVN)	HW =(HWP)-(HWN)	U	V	W
1	Middle	Low	High	PWM	Low	PWM
2	High	Low	High	PWM	Low	PWM
3	High	Low	Middle	PWM	Low to PWM	PWM to Low
4	High	Low	Low	PWM	PWM	Low
5	High	Middle	Low	PWM	PWM	Low
6	High	High	Low	PWM	PWM	Low
7	Middle	High	Low	PWM to Low	PWM	Low to PWM
8	Low	High	Low	Low	PWM	PWM
9	Low	High	Middle	Low	PWM	PWM
10	Low	High	High	Low	PWM	PWM
11	Low	Middle	High	Low to PWM	PWM to Low	PWM
12	Low	Low	High	PWM	Low	PWM

2. Lock Protection Function (MLP: Motor Lock Protection)

When the motor is locked due to disturbance factors, the IC has a protection function that turns off all external FETs for a certain period (lock protection time t_{LK_PRT} : 5.0 s [Typ]) so that the current will not continue to flow in the coil current. In addition, it has a function that automatically restarts after lock protection time. Hall signal transitions are detected as the motor rotates. But when the motor is locked, they are not detected. When they are not detected for a certain period (lock protection detect time t_{LK_DET} : 0.5 s [Typ]), the IC judges as the motor is locked. The timing chart of the Hall signal and each output phase during lock protection is shown in Figure 3.

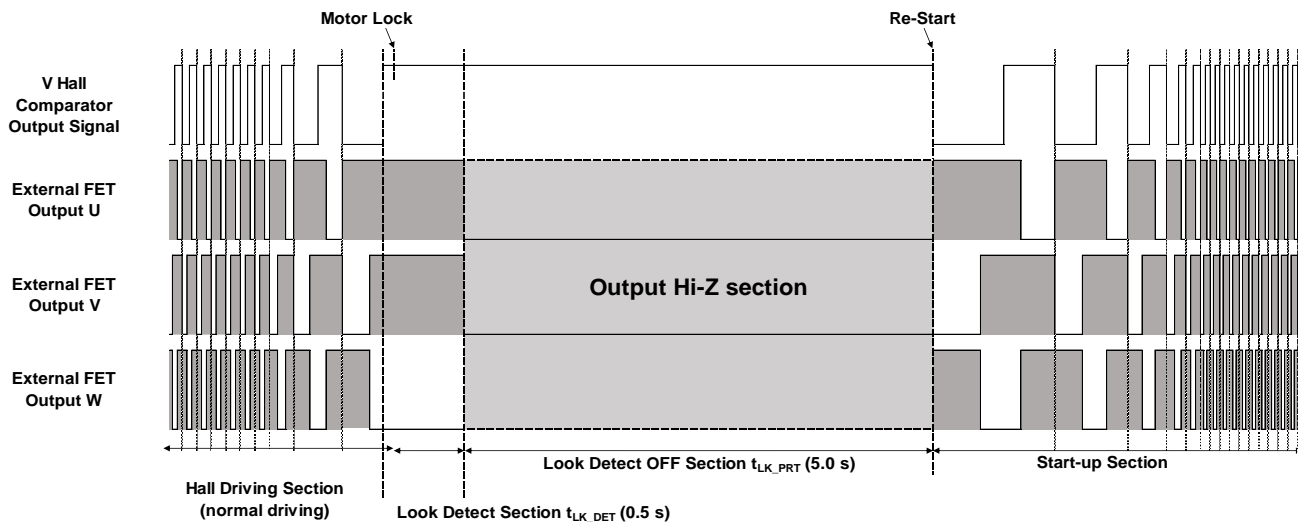

Figure 3. Timing Chart during Lock Protection

Description of Operations – Continued

3. Current Limit Setting (the RCL pin)

When the IC detects the coil current the current setting value or more, all high side external FETs are turned off and cut off the current. When the current is less than the current value setting in the timing of next PWM (ON) after that, it returns to normal drive. Setting current value I_O that operates the current limit is determined on the current limit setting voltage (V_{CL}) 0.2 V (Typ) in the IC and the resistance R_1 to use for the coil current detection. Please refer to the formula shown below in the case of $R_1=0.2 \Omega$.

$$\begin{aligned}
 I_O [A] &= V_{CL} [V] / R_1 [\Omega] \\
 &= 0.2 / 0.2 \\
 &= 1.0 A
 \end{aligned}$$

$$\begin{aligned}
 P_C [W] &= V_{CL} [V] \times I_O [A] \\
 &= 0.2 \times 1.0 \\
 &= 0.2 W
 \end{aligned}$$

When the current limit function is not used, short the RCL pin with the GND. A large current flows through the resistor R_1 to detect the coil current. Because the power consumption P_C is calculated with the formula shown above, please pay attention to the power dissipation.

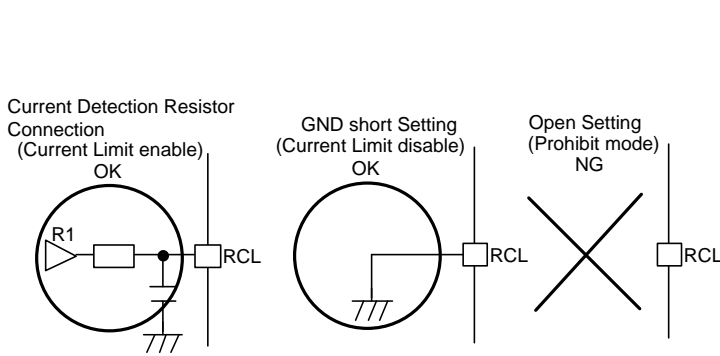

Figure 4. RCL Pin Process

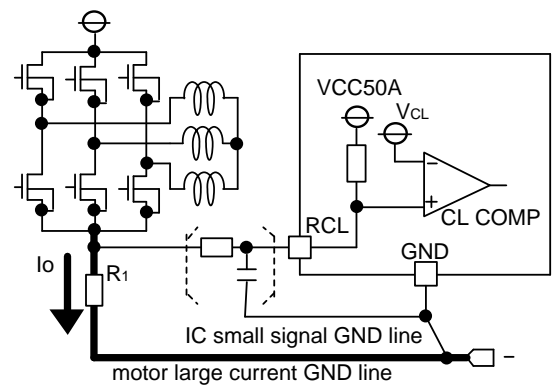

Figure 5. Small Signal and Large Current GND Line Separation

When design a PCB layout, separate the IC small signal GND line from the motor large current GND line connected to R_1 as shown in Figure 5.

4. Soft Start Time Setting (the SS_SEL pin)

When it starts from a motor stop state, there is a function to increase the VCC current gradually (Soft Start function) for controlling the inrush current. In the start-up command to start from the motor stop state, there are the start by the power supply injection, the start by the torque input (the PWMB pin), the start by the power save cancellation (the PS pin), the return from lock protection, the return from the short brake mode at the time of the rotational direction change (the FR pin), and the return from the motor stop state by each protection function (High Speed Rotation Protection, Over Voltage Lock Out, Under Voltage Lock Out and Thermal Shutdown). About the current limit during Soft Start, it maintains the sine wave drive by gradually increasing the output duty of the external FET.

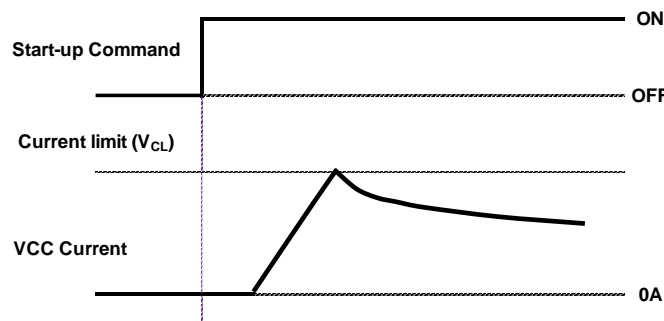

Figure 6. Timing Chart of the Coil Current Waveform at Soft Start

4. Soft Start Time Setting (the SS_SEL pin) – Continued

The Soft Start function can gradually increase the current limit setting voltage in the IC. The Time for 1 step is set on the voltage of the SS_SEL pin as shown in Table 5. In addition, set it in consideration of ±10 % tolerance of the Time for 1 step. The current limit setting voltage in the IC increases for 1 step voltage 5.16 mV (Typ). Therefore, the soft start time can be calculated as follows.

$$\text{Soft Start time} = \text{Time for 1 step} \times (V_{CL} - 51.6 \text{ mV}) / 5.16 \text{ mV}$$

For example, when SS_SEL=0 V, it is calculated as below.

$$\text{Soft Start time} = 49 \text{ ms} \times (200 \text{ mV} - 51.6 \text{ mV}) / 5.16 \text{ mV} = 1.4 \text{ s}$$

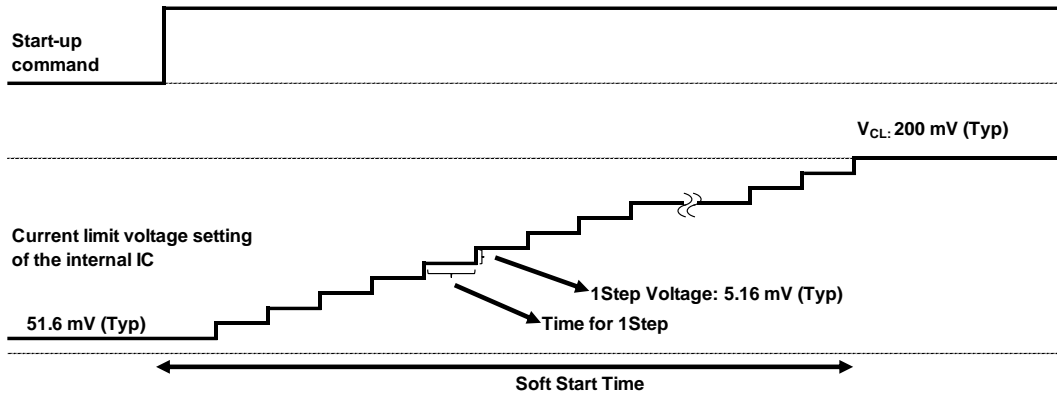

Figure 7. Timing Chart of the Current Limit Voltage Setting during Soft Start

Table 5. SS_SEL Pin Setting Table

SS_SEL pin Setting						Time for 1 step (Typ)	
0.000	x	V _{VCC50}	to	0.056	x	V _{VCC50}	49 ms
0.069	x	V _{VCC50}	to	0.119	x	V _{VCC50}	98 ms
0.131	x	V _{VCC50}	to	0.181	x	V _{VCC50}	147 ms
0.194	x	V _{VCC50}	to	0.244	x	V _{VCC50}	197 ms
0.256	x	V _{VCC50}	to	0.306	x	V _{VCC50}	246 ms
0.319	x	V _{VCC50}	to	0.369	x	V _{VCC50}	295 ms
0.381	x	V _{VCC50}	to	0.431	x	V _{VCC50}	344 ms
0.444	x	V _{VCC50}	to	0.494	x	V _{VCC50}	393 ms
0.506	x	V _{VCC50}	to	0.556	x	V _{VCC50}	442 ms
0.569	x	V _{VCC50}	to	0.619	x	V _{VCC50}	491 ms
0.631	x	V _{VCC50}	to	0.681	x	V _{VCC50}	541 ms
0.694	x	V _{VCC50}	to	0.744	x	V _{VCC50}	590 ms
0.756	x	V _{VCC50}	to	0.806	x	V _{VCC50}	639 ms
0.819	x	V _{VCC50}	to	0.869	x	V _{VCC50}	688 ms
0.881	x	V _{VCC50}	to	0.931	x	V _{VCC50}	737 ms
0.944	x	V _{VCC50}	to	1.000	x	V _{VCC50}	786 ms

Description of Operations – Continued

5. Dead Time Setting (the TDEAD_SEL pin)

It can perform Dead Time setting with the TDEAD_SEL pin. Dead Time is set on the voltage of the TDEAD_SEL pin as shown in Table 6. Set it in consideration of ±10 % tolerance of the Dead Time.

$$TDEAD_SEL \text{ voltage} = \left(\frac{10^7}{32} \times \text{Dead Time} + \frac{1}{64} \right) \times V_{VCC50}$$

Table 6. TDEAD_SEL Pin Setting Table

TDEAD_SEL pin Setting						Dead Time (Typ)	
0.000	x	V _{VCC50}	to	0.028	x	V _{VCC50}	0.1 μs
0.034	x	V _{VCC50}	to	0.060	x	V _{VCC50}	0.1 μs
0.063	x	V _{VCC50}	to	0.091	x	V _{VCC50}	0.2 μs
0.094	x	V _{VCC50}	to	0.122	x	V _{VCC50}	0.3 μs
0.125	x	V _{VCC50}	to	0.153	x	V _{VCC50}	0.4 μs
0.156	x	V _{VCC50}	to	0.185	x	V _{VCC50}	0.5 μs
0.191	x	V _{VCC50}	to	0.216	x	V _{VCC50}	0.6 μs
0.222	x	V _{VCC50}	to	0.247	x	V _{VCC50}	0.7 μs
0.253	x	V _{VCC50}	to	0.278	x	V _{VCC50}	0.8 μs
0.281	x	V _{VCC50}	to	0.310	x	V _{VCC50}	0.9 μs
0.313	x	V _{VCC50}	to	0.341	x	V _{VCC50}	1.0 μs
...					
0.909	x	V _{VCC50}	to	0.935	x	V _{VCC50}	2.9 μs
0.941	x	V _{VCC50}	to	0.966	x	V _{VCC50}	3.0 μs
0.972	x	V _{VCC50}	to	1.000	x	V _{VCC50}	3.1 μs

6. Motor Pole Setting (the POLE_SEL pin)

Set the POLE_SEL pin voltage based on the motor poles. Refer to Table 7 for setting. For other motor poles setting, refer to the Application Note.

Table 7. POLE_SEL Pin Setting Table

POLE_SEL pin Setting						Motor Pole (poles)	
0.00	x	V _{VCC50}	to	0.13	x	V _{VCC50}	4
0.16	x	V _{VCC50}	to	0.27	x	V _{VCC50}	6
0.30	x	V _{VCC50}	to	0.41	x	V _{VCC50}	8
0.44	x	V _{VCC50}	to	0.56	x	V _{VCC50}	2
0.59	x	V _{VCC50}	to	0.70	x	V _{VCC50}	12
0.73	x	V _{VCC50}	to	0.84	x	V _{VCC50}	14
0.87	x	V _{VCC50}	to	1.00	x	V _{VCC50}	10

Description of Operations – Continued

7. Under Voltage Lock Out (UVLO)
 In extremely low supply voltage domain deviating from normal operation, it is a protection function that prevents the unexpected operations such as large current flow in drive FET by turning off all external FETs intentionally. UVLO works and all external FETs are turned off when V_{CC} reaches 18 V (Typ) or less in the domain less than 28 V of the recommended operating minimum voltage. And the regulator outputs (VREG, VREG15) are turned off. UVLO circuit has hysteresis of 2 V (Typ), and UVLO is cancelled when V_{CC} reaches 20 V (Typ) or more.
8. VG Under Voltage Lock Out (VG UVLO)
 When V_G reaches $V_{CC}+3.0$ V (Typ) or less, VG UVLO works and all external FETs are turned off. VG UVLO circuit has no hysteresis.
9. Over Voltage Lock Out (OVLO)
 When V_{CC} reaches 72 V (Typ) or more, OVLO works and it enters short brake mode, wherein all high side external FETs are turned off and all low side external FETs are turned on for a certain period (protect time t_{LK_PRT} : 5.0 s [Typ]). In addition, the boost function for VG voltage is turned off. OVLO circuit has hysteresis of 3 V (Typ), and OVLO is cancelled when V_{CC} reaches 69 V (Typ) or less after the protect time. This circuit has mask time of 4 μ s (Typ) to prevent malfunctions.
10. High Speed Rotation Protection
 When a rotating speed reaches 40,300 rpm (Typ) or more due to boost up by uncontrollable motor, it has the protection function which turn off all external FETs for a certain period (protect time t_{LK_PRT} : 5.0 s [Typ]). After the Protect time, the High Speed Rotation Protection is cancelled when a rotating speed reaches less than 40,300 rpm (Typ).
11. Thermal Shutdown (TSD)
 When the chip temperature reaches 175 °C (Typ) or more, TSD works and all external FETs are turned off for a certain period (protect time t_{LK_PRT} : 5.0 s [Typ]). TSD circuit has hysteresis of 25 °C (Typ), and TSD is cancelled when the chip temperature drops after the protect time. Moreover, the purpose of the TSD circuit is to protect driver IC from thermal breakdown, therefore, temperature of this circuit will be over working temperature when it is started up. Thus, thermal design should have sufficient margin, so do not take continuous use and action of the circuit as a precondition.
12. Over Current Protection (OCP)
 Built-in Over Current Protection circuit is possible to protect from power supply short fault only. When the specified current or more is detected, OCP works and all external FETs are turned off for a certain period (protect time t_{LK_PRT} : 5.0 s [Typ]). When it is not detected after the protect time, OCP is canceled.
13. Hall input error protection (HALL ERROR)
 When Hall input is abnormal, the Hall input error protection works and all external FETs are turned off. This protection has the mask time of 1.0 ms (Typ). Once protection is operated, it continues until it is cancelled by restart from the operation of Power Save, Speed Control Non-input or V_{CC} off.
14. Priority of Protection
 This IC has a priority order in each protection operation as shown below. The protection with higher priority will be activated during the protection with lower priority.

Table 8. Priority Order of Protect Operation

Priority Order	Protection
1st	VCC UVLO
2nd	OCP
3rd	TSD
4th	OVLO
5th	MLP, High Speed Rotation Protection, Hall Error Protection, VG UVLO

Description of Operations – Continued

15. Auto Lead Angle Control

It has the auto lead angle function which enables a high efficiency drive by matching the phase of the coil current to the phase of the Back EMF voltage generated to the coil automatically while driving the motor. To do that, place Hall sensors in reference to Figure 8 so that the timing of the Hall sensor signal and the coil current at the lead angle 0° becomes Figure 1 (U→V→W) or Figure 2 (U→W→V). The lead angle adjustment range is from 0° to 45°.

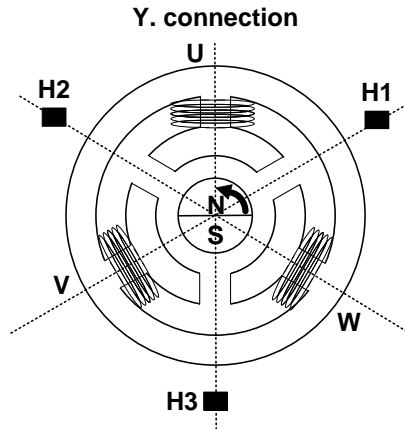

Figure 8. The Placement of Hall sensors

16. VCC50 Voltage

It is recommended to use the reference voltage circuit using an external NPN transistor about countermeasures for heat generation. This circuit is shown in Figure 9. VCC50 voltage is 5 V (Typ) by this circuit. Current of 2.6 mA (Typ) to the VCC pin and total current 10.4 mA (Typ) to the VCC50A and VCC50B pin flow.

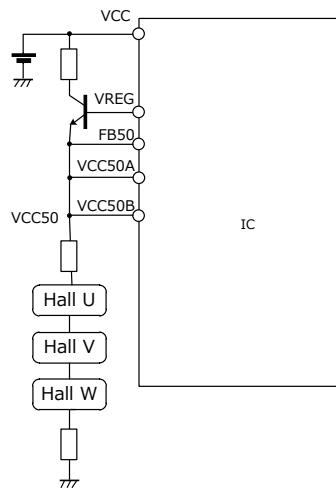

Figure 9. The Reference voltage circuit using external NPN transistor

Thermal Resistance Model

Heat generated by consumed power of IC is radiated from the mold resin or lead frame of package. The parameter which indicates this heat dissipation capability (hardness of heat release) is called thermal resistance. Thermal resistance from the chip junction to the ambient is represented in θ_{JA} ($^{\circ}\text{C}/\text{W}$), and thermal characterization parameter from junction to the top center of the outside surface of the component package is represented in Ψ_{JT} ($^{\circ}\text{C}/\text{W}$). Thermal resistance is divided into the package part and the substrate part. Thermal resistance in the package part depends on the composition materials such as the mold resins and the lead frames. On the other hand, thermal resistance in the substrate part depends on the substrate heat dissipation capability of the material, the size, and the copper foil area etc. Therefore, thermal resistance can be decreased by the heat radiation measures like installing a heat sink etc. in the mounting substrate. The equations are shown below and the thermal resistance model is shown in Figure 10.

Equation

$$\theta_{JA} = \frac{Tj - Ta}{P} \text{ [}^{\circ}\text{C/W]}$$

$$\psi_{JT} = \frac{Tj - Tt}{P} \text{ [}^{\circ}\text{C/W]}$$

Where:

- θ_{JA} is the thermal resistance from junction to ambient ($^{\circ}\text{C}/\text{W}$)
- ψ_{JT} is the thermal characterization parameter from junction to the top center of the outside surface of the component package ($^{\circ}\text{C}/\text{W}$)
- Tj is the junction temperature ($^{\circ}\text{C}$)
- Ta is the ambient temperature ($^{\circ}\text{C}$)
- Tt is the package outside surface (top center) temperature ($^{\circ}\text{C}$)
- P is the power consumption (W)

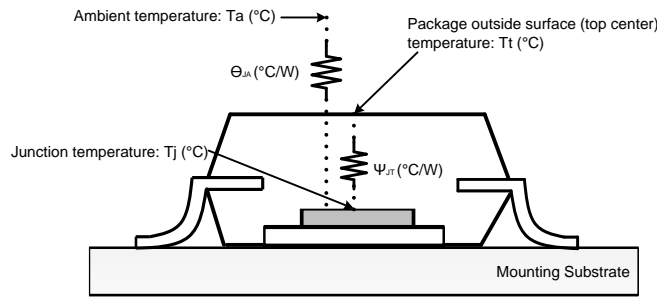
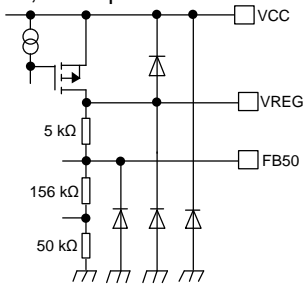

Figure 10. Thermal Resistance Model of Surface Mount

Even if it uses the same package, θ_{JA} and Ψ_{JT} are changed depending on the chip size, power consumption and the measurement environments of the ambient temperature, the mounting condition and the wind velocity, etc.

I/O Equivalence Circuits

1) VREG, FB50 pin



2) VREG15 pin

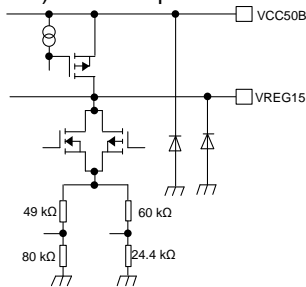

3) PS pin

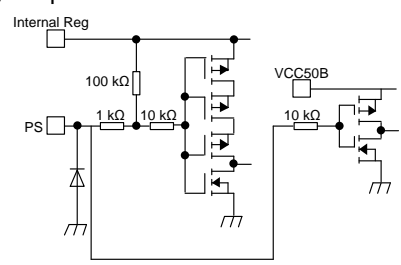

4) BRK pin

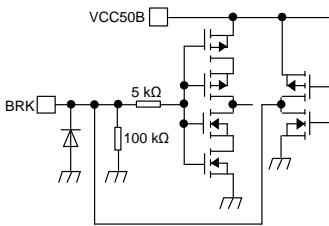

5) FR pin

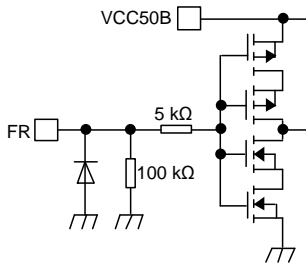

6) TEST pin

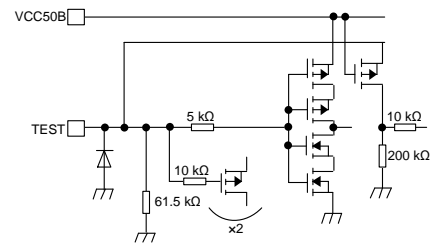

7) POLE_SEL, PWMB pin

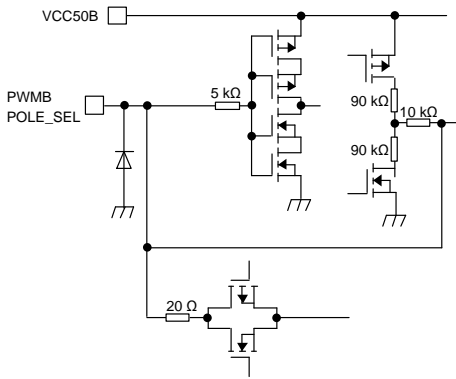

8) SS_SEL pin

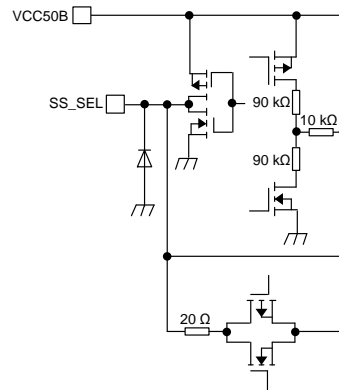

9) TDEAD_SEL pin

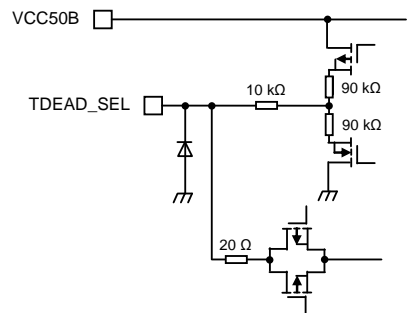

10) VG, UH, U, VH, V, WH, W pin

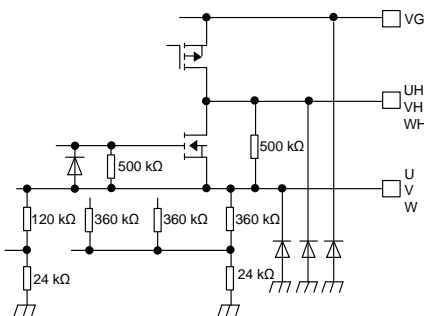

11) UL, VL, WL pin

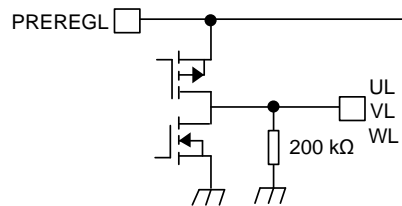

12) FGO pin

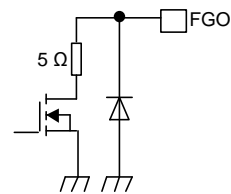

13) CP pin

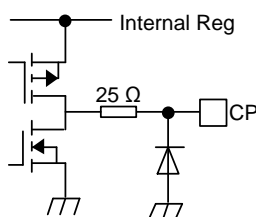

14) RCL pin

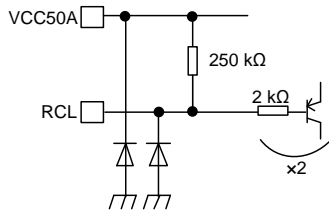

15) PREREGL pin

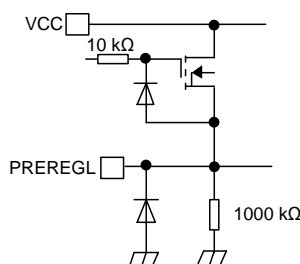

16) HUP, HUN, HVP, HVN, HWP, HWN pin

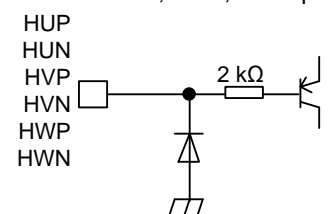

Operational Notes

1. Reverse Connection of Power Supply

Connecting the power supply in reverse polarity can damage the IC. Take precautions against reverse polarity when connecting the power supply, such as mounting an external diode between the power supply and the IC's power supply pins.

2. Power Supply Lines

Design the PCB layout pattern to provide low impedance supply lines. Furthermore, connect a capacitor to ground at all power supply pins. Consider the effect of temperature and aging on the capacitance value when using electrolytic capacitors.

3. Ground Voltage

Ensure that no pins are at a voltage below that of the ground pin at any time, even during transient condition. However, pins that drive inductive loads (e.g. motor driver outputs, DC-DC converter outputs) may inevitably go below ground due to back EMF or electromotive force. In such cases, the user should make sure that such voltages going below ground will not cause the IC and the system to malfunction by examining carefully all relevant factors and conditions such as motor characteristics, supply voltage, operating frequency and PCB wiring to name a few.

4. Ground Wiring Pattern

When using both small-signal and large-current ground traces, the two ground traces should be routed separately but connected to a single ground at the reference point of the application board to avoid fluctuations in the small-signal ground caused by large currents. Also ensure that the ground traces of external components do not cause variations on the ground voltage. The ground lines must be as short and thick as possible to reduce line impedance.

5. Recommended Operating Conditions

The function and operation of the IC are guaranteed within the range specified by the recommended operating conditions. The characteristic values are guaranteed only under the conditions of each item specified by the electrical characteristics.

6. Inrush Current

When power is first supplied to the IC, it is possible that the internal logic may be unstable and inrush current may flow instantaneously due to the internal powering sequence and delays, especially if the IC has more than one power supply. Therefore, give special consideration to power coupling capacitance, power wiring, width of ground wiring, and routing of connections.

7. Testing on Application Boards

When testing the IC on an application board, connecting a capacitor directly to a low-impedance output pin may subject the IC to stress. Always discharge capacitors completely after each process or step. The IC's power supply should always be turned off completely before connecting or removing it from the test setup during the inspection process. To prevent damage from static discharge, ground the IC during assembly and use similar precautions during transport and storage.

8. Inter-pin Short and Mounting Errors

Ensure that the direction and position are correct when mounting the IC on the PCB. Incorrect mounting may result in damaging the IC. Avoid nearby pins being shorted to each other especially to ground, power supply and output pin. Inter-pin shorts could be due to many reasons such as metal particles, water droplets (in very humid environment) and unintentional solder bridge deposited in between pins during assembly to name a few.

9. Unused Input Pins

Input pins of an IC are often connected to the gate of a MOS transistor. The gate has extremely high impedance and extremely low capacitance. If left unconnected, the electric field from the outside can easily charge it. The small charge acquired in this way is enough to produce a significant effect on the conduction through the transistor and cause unexpected operation of the IC. So unless otherwise specified, unused input pins should be connected to the power supply or ground line.

Operational Notes – continued

10. Regarding the Input Pin of the IC

This IC contains P+ isolation and P substrate layers between adjacent elements in order to keep them isolated. P-N junctions are formed at the intersection of the P layers with the N layers of other elements, creating a parasitic diode or transistor. For example (refer to figure below):

- When GND > Pin A and GND > Pin B, the P-N junction operates as a parasitic diode.
- When GND > Pin B, the P-N junction operates as a parasitic transistor.

Parasitic diodes inevitably occur in the structure of the IC. The operation of parasitic diodes can result in mutual interference among circuits, operational faults, or physical damage. Therefore, conditions that cause these diodes to operate, such as applying a voltage lower than the GND voltage to an input pin (and thus to the P substrate) should be avoided.

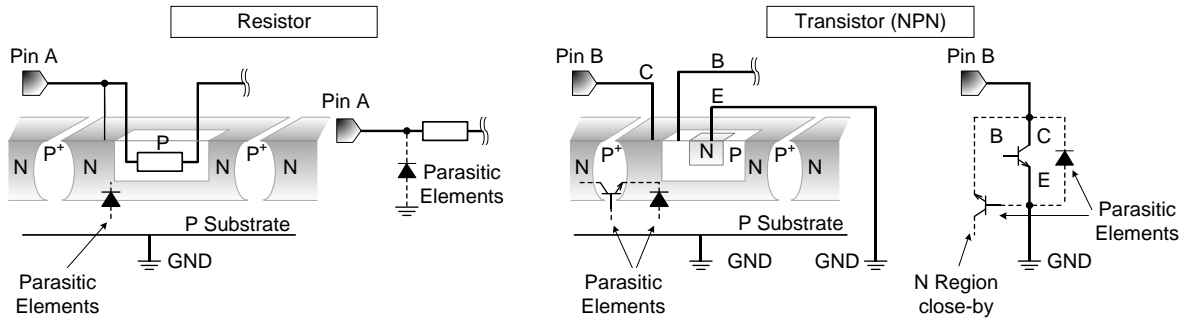

Figure 11. Example of IC Structure

11. Ceramic Capacitor

When using a ceramic capacitor, determine a capacitance value considering the change of capacitance with temperature and the decrease in nominal capacitance due to DC bias and others.

12. Thermal Shutdown Circuit (TSD)

This IC has a built-in thermal shutdown circuit that prevents heat damage to the IC. Normal operation should always be within the IC's maximum junction temperature rating. If however the rating is exceeded for a continued period, the junction temperature (Tj) will rise which will activate the TSD circuit that will turn OFF power output pins. When the Tj falls below the TSD threshold, the circuits are automatically restored to normal operation.

Note that the TSD circuit operates in a situation that exceeds the absolute maximum ratings and therefore, under no circumstances, should the TSD circuit be used in a set design or for any purpose other than protecting the IC from heat damage.

13. Over Current Protection Circuit (OCP)

This IC incorporates an integrated overcurrent protection circuit that is activated when the load is shorted. This protection circuit is effective in preventing damage due to sudden and unexpected incidents. However, the IC should not be used in applications characterized by continuous operation or transitioning of the protection circuit.

Ordering Information

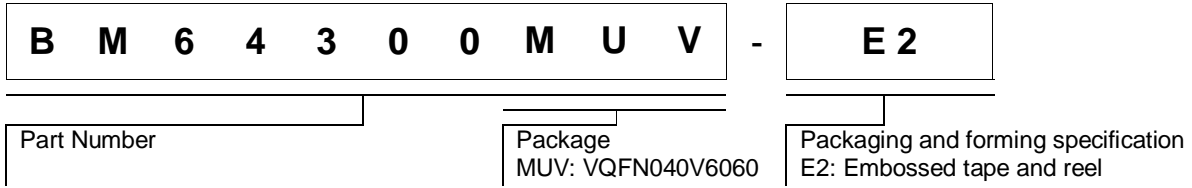

Marking Diagram

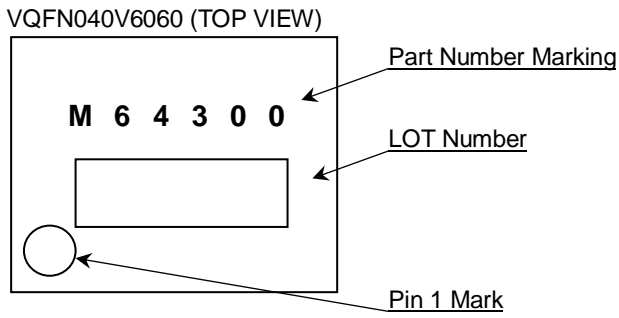

Physical Dimension and Packing Information

Package Name	VQFN040V6060
--------------	--------------

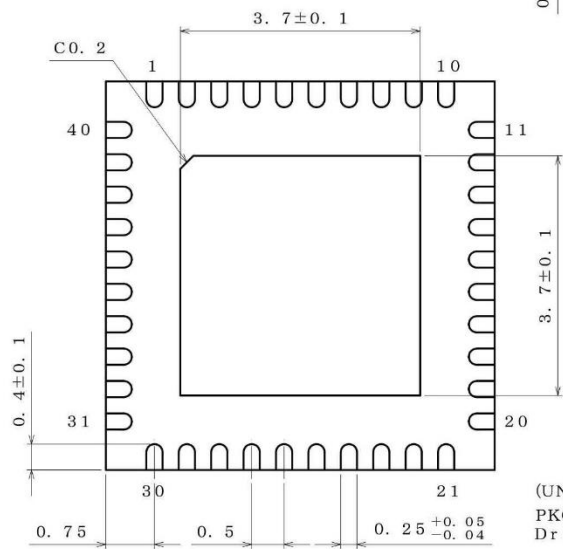
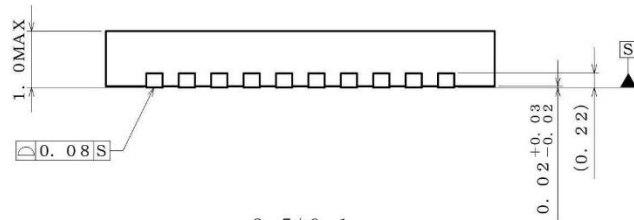
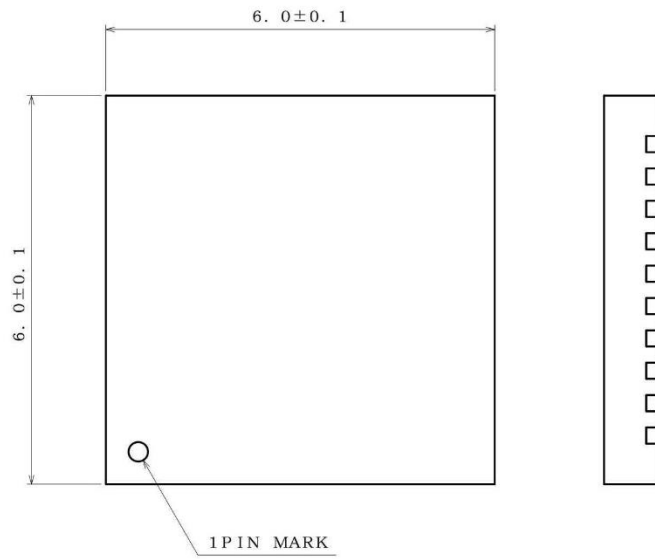

(UNIT : mm)
PKG : VQFN040V6060
Drawing No. EX464-5001-1

<Tape and Reel information>

Tape	Embossed carrier tape
Quantity	2000pcs
Direction of feed	E2 (The direction is the 1pin of product is at the upper left when you hold reel on the left hand and you pull out the tape on the right hand)

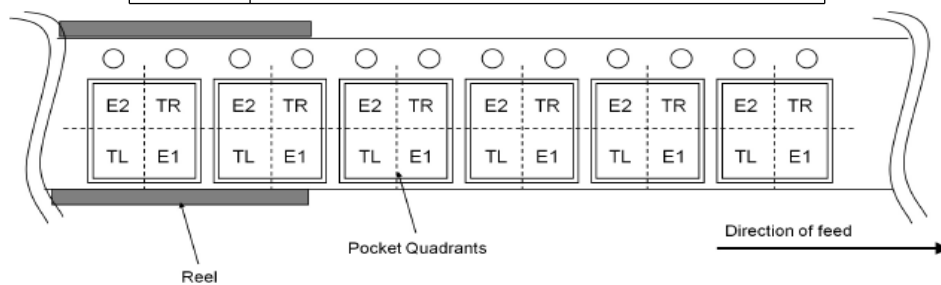

Revision History

Date	Revision	Changes
23.Jan.2019	001	New Release

Notice

Precaution on using ROHM Products

- Our Products are designed and manufactured for application in ordinary electronic equipment (such as AV equipment, OA equipment, telecommunication equipment, home electronic appliances, amusement equipment, etc.). If you intend to use our Products in devices requiring extremely high reliability (such as medical equipment ^(Note 1), transport equipment, traffic equipment, aircraft/spacecraft, nuclear power controllers, fuel controllers, car equipment including car accessories, safety devices, etc.) and whose malfunction or failure may cause loss of human life, bodily injury or serious damage to property ("Specific Applications"), please consult with the ROHM sales representative in advance. Unless otherwise agreed in writing by ROHM in advance, ROHM shall not be in any way responsible or liable for any damages, expenses or losses incurred by you or third parties arising from the use of any ROHM's Products for Specific Applications.

(Note1) Medical Equipment Classification of the Specific Applications

JAPAN	USA	EU	CHINA
CLASS III	CLASS III	CLASS II b	CLASS III
CLASS IV		CLASS III	

- ROHM designs and manufactures its Products subject to strict quality control system. However, semiconductor products can fail or malfunction at a certain rate. Please be sure to implement, at your own responsibilities, adequate safety measures including but not limited to fail-safe design against the physical injury, damage to any property, which a failure or malfunction of our Products may cause. The following are examples of safety measures:
 - Installation of protection circuits or other protective devices to improve system safety
 - Installation of redundant circuits to reduce the impact of single or multiple circuit failure
- Our Products are designed and manufactured for use under standard conditions and not under any special or extraordinary environments or conditions, as exemplified below. Accordingly, ROHM shall not be in any way responsible or liable for any damages, expenses or losses arising from the use of any ROHM's Products under any special or extraordinary environments or conditions. If you intend to use our Products under any special or extraordinary environments or conditions (as exemplified below), your independent verification and confirmation of product performance, reliability, etc. prior to use, must be necessary:
 - Use of our Products in any types of liquid, including water, oils, chemicals, and organic solvents
 - Use of our Products outdoors or in places where the Products are exposed to direct sunlight or dust
 - Use of our Products in places where the Products are exposed to sea wind or corrosive gases, including Cl₂, H₂S, NH₃, SO₂, and NO₂
 - Use of our Products in places where the Products are exposed to static electricity or electromagnetic waves
 - Use of our Products in proximity to heat-producing components, plastic cords, or other flammable items
 - Sealing or coating our Products with resin or other coating materials
 - Use of our Products without cleaning residue of flux (Exclude cases where no-clean type fluxes is used. However, recommend sufficiently about the residue.) ; or Washing our Products by using water or water-soluble cleaning agents for cleaning residue after soldering
 - Use of the Products in places subject to dew condensation
- The Products are not subject to radiation-proof design.
- Please verify and confirm characteristics of the final or mounted products in using the Products.
- In particular, if a transient load (a large amount of load applied in a short period of time, such as pulse, is applied, confirmation of performance characteristics after on-board mounting is strongly recommended. Avoid applying power exceeding normal rated power; exceeding the power rating under steady-state loading condition may negatively affect product performance and reliability.
- De-rate Power Dissipation depending on ambient temperature. When used in sealed area, confirm that it is the use in the range that does not exceed the maximum junction temperature.
- Confirm that operation temperature is within the specified range described in the product specification.
- ROHM shall not be in any way responsible or liable for failure induced under deviant condition from what is defined in this document.

Precaution for Mounting / Circuit board design

- When a highly active halogenous (chlorine, bromine, etc.) flux is used, the residue of flux may negatively affect product performance and reliability.
- In principle, the reflow soldering method must be used on a surface-mount products, the flow soldering method must be used on a through hole mount products. If the flow soldering method is preferred on a surface-mount products, please consult with the ROHM representative in advance.

For details, please refer to ROHM Mounting specification

Precautions Regarding Application Examples and External Circuits

1. If change is made to the constant of an external circuit, please allow a sufficient margin considering variations of the characteristics of the Products and external components, including transient characteristics, as well as static characteristics.
2. You agree that application notes, reference designs, and associated data and information contained in this document are presented only as guidance for Products use. Therefore, in case you use such information, you are solely responsible for it and you must exercise your own independent verification and judgment in the use of such information contained in this document. ROHM shall not be in any way responsible or liable for any damages, expenses or losses incurred by you or third parties arising from the use of such information.

Precaution for Electrostatic

This Product is electrostatic sensitive product, which may be damaged due to electrostatic discharge. Please take proper caution in your manufacturing process and storage so that voltage exceeding the Products maximum rating will not be applied to Products. Please take special care under dry condition (e.g. Grounding of human body / equipment / solder iron, isolation from charged objects, setting of Ionizer, friction prevention and temperature / humidity control).

Precaution for Storage / Transportation

1. Product performance and soldered connections may deteriorate if the Products are stored in the places where:
 - [a] the Products are exposed to sea winds or corrosive gases, including Cl₂, H₂S, NH₃, SO₂, and NO₂
 - [b] the temperature or humidity exceeds those recommended by ROHM
 - [c] the Products are exposed to direct sunshine or condensation
 - [d] the Products are exposed to high Electrostatic
2. Even under ROHM recommended storage condition, solderability of products out of recommended storage time period may be degraded. It is strongly recommended to confirm solderability before using Products of which storage time is exceeding the recommended storage time period.
3. Store / transport cartons in the correct direction, which is indicated on a carton with a symbol. Otherwise bent leads may occur due to excessive stress applied when dropping of a carton.
4. Use Products within the specified time after opening a humidity barrier bag. Baking is required before using Products of which storage time is exceeding the recommended storage time period.

Precaution for Product Label

A two-dimensional barcode printed on ROHM Products label is for ROHM's internal use only.

Precaution for Disposition

When disposing Products please dispose them properly using an authorized industry waste company.

Precaution for Foreign Exchange and Foreign Trade act

Since concerned goods might be fallen under listed items of export control prescribed by Foreign exchange and Foreign trade act, please consult with ROHM in case of export.

Precaution Regarding Intellectual Property Rights

1. All information and data including but not limited to application example contained in this document is for reference only. ROHM does not warrant that foregoing information or data will not infringe any intellectual property rights or any other rights of any third party regarding such information or data.
2. ROHM shall not have any obligations where the claims, actions or demands arising from the combination of the Products with other articles such as components, circuits, systems or external equipment (including software).
3. No license, expressly or implied, is granted hereby under any intellectual property rights or other rights of ROHM or any third parties with respect to the Products or the information contained in this document. Provided, however, that ROHM will not assert its intellectual property rights or other rights against you or your customers to the extent necessary to manufacture or sell products containing the Products, subject to the terms and conditions herein.

Other Precaution

1. This document may not be reprinted or reproduced, in whole or in part, without prior written consent of ROHM.
2. The Products may not be disassembled, converted, modified, reproduced or otherwise changed without prior written consent of ROHM.
3. In no event shall you use in any way whatsoever the Products and the related technical information contained in the Products or this document for any military purposes, including but not limited to, the development of mass-destruction weapons.
4. The proper names of companies or products described in this document are trademarks or registered trademarks of ROHM, its affiliated companies or third parties.

General Precaution

1. Before you use our Products, you are requested to carefully read this document and fully understand its contents. ROHM shall not be in any way responsible or liable for failure, malfunction or accident arising from the use of any ROHM's Products against warning, caution or note contained in this document.
2. All information contained in this document is current as of the issuing date and subject to change without any prior notice. Before purchasing or using ROHM's Products, please confirm the latest information with a ROHM sales representative.
3. The information contained in this document is provided on an "as is" basis and ROHM does not warrant that all information contained in this document is accurate and/or error-free. ROHM shall not be in any way responsible or liable for any damages, expenses or losses incurred by you or third parties resulting from inaccuracy or errors of or concerning such information.