

Automotive IPD 1ch/2ch Low Side Switch

BV1LC300FJ-C BM2LC300FJ-C

Features

- AEC-Q100 Qualified^(Note 1)
- Built-in Over Current Protection Function(OCP)
- Built-in Thermal Shutdown Function (TSD)
- Built-in Active Clamp Function
- Built-in Diagnostic Function
- Direct Control Enabled from CMOS Logic IC, etc.
- On Resistance $R_{DS(ON)} = 350\text{ m}\Omega$ (Typ)
(when $V_{IN} = 5\text{ V}$, $I_{OUT} = 0.5\text{ A}$, $T_j = 25\text{ }^\circ\text{C}$)
- Monolithic Power Management IC with the Control Block (CMOS) and Power MOS FET Mounted on a Single Chip

^(Note 1) Grade1

Key Specifications

On-state Resistance ($T_j = 25\text{ }^\circ\text{C}$, Typ)	350 m Ω
Over Current Detection Current ($T_j = 25\text{ }^\circ\text{C}$, Typ)	2.7 A
Output Clamp Voltage (Min)	42 V
Active Clamp Energy ($T_{j(START)} = 25\text{ }^\circ\text{C}$)	300 mJ

Package
SOP-J8

W (Typ) x D (Typ) x H (Max)
4.90mm x 6.00mm x 1.65mm



General Description

The BV1LC300FJ-C is 1ch, BM2LC300FJ-C is 2ch automotive low side switch IC, which has built-in OCP, TSD, active clamp function. Also, diagnostic function can diagnose OCP, TSD, open load detection function (OLD).

Application

- Driving Resistive, Inductive and Capacitive Load

Block Diagram^(Note 1)

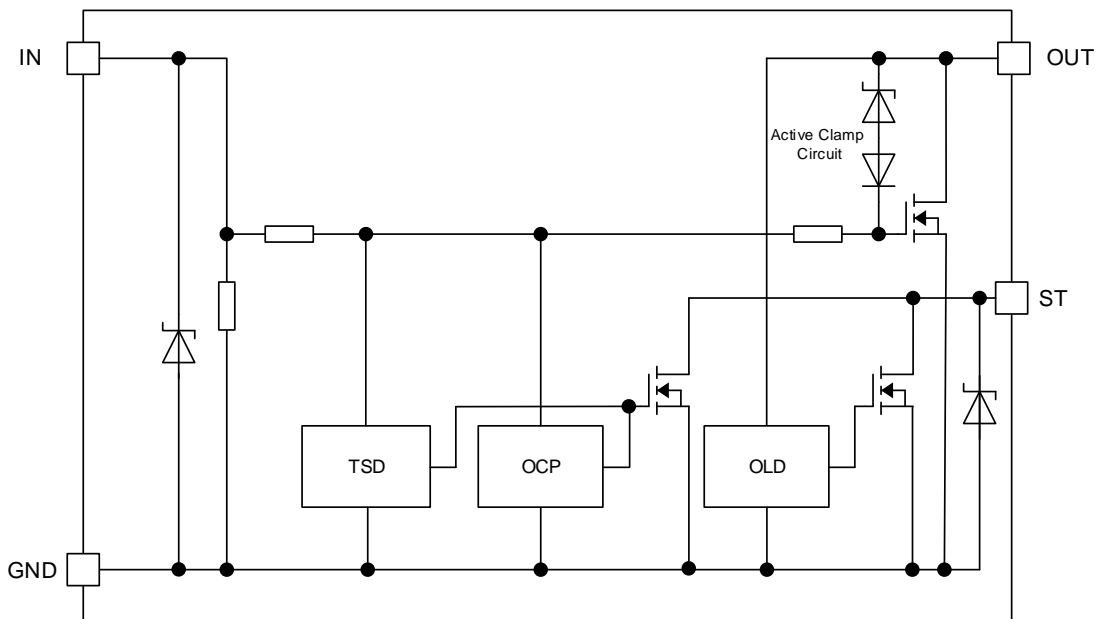

Figure 1. Block Diagram

^(Note 1) BV1LC300FJ-C and BM2LC300FJ-C use same block diagram. BM2LC300FJ-C just double it.

Contents

Features.....	1
General Description	1
Application	1
Key Specifications.....	1
Package.....	1
Block Diagram	1
Pin Configuration	3
Pin Description.....	3
Term.....	4
Absolute Maximum Ratings	4
Recommended Operating Conditions	4
Thermal Resistance.....	5
Electrical Characteristics.....	9
Typical Performance Curves.....	11
Measurement Circuit for Typical Performance Curves.....	18
I/O Pin Truth Table	20
Timing Chart	20
Operational Notes.....	22
Ordering Information.....	24
Marking Diagram	24
Physical Dimension and Packing Information	25
Revision History.....	26

Pin Configuration

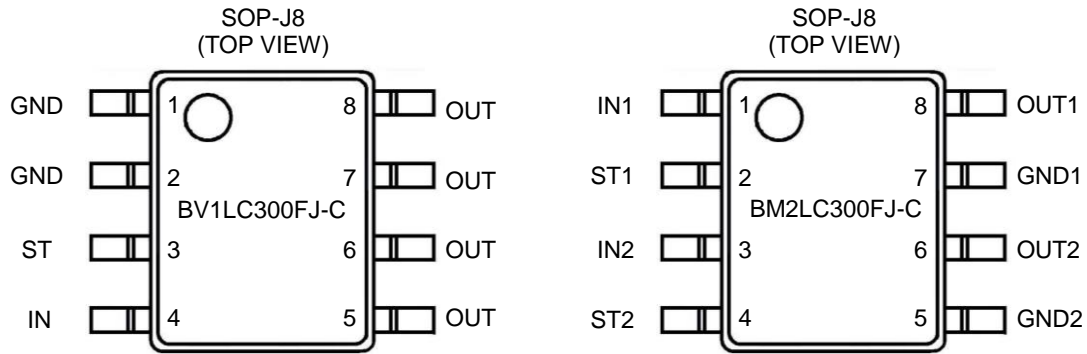

Figure 2. Pin Configuration

Pin Description

■ BV1LC300FJ-C

Pin No.	Pin Name	Function
1	GND	GND pin.
2	GND	GND pin.
3	ST	Self-diagnostic output pin.
4	IN	Input pin, with internal pull-down resistor.
5	OUT	Output pin. When output pin shorted to battery and output current exceeding the over current detection value, output current will be limited to protect IC.
6	OUT	Output pin. When output pin shorted to battery and output current exceeding the over current detection value, output current will be limited to protect IC.
7	OUT	Output pin. When output pin shorted to battery and output current exceeding the over current detection value, output current will be limited to protect IC.
8	OUT	Output pin. When output pin shorted to battery and output current exceeding the over current detection value, output current will be limited to protect IC.

■ BM2LC300FJ-C

Pin No.	Pin Name ^(Note 1)	Function
1	IN1	Input pin 1, with internal pull-down resistor.
2	ST1	Self-diagnostic output pin 1.
3	IN2	Input pin 2, with internal pull-down resistor.
4	ST2	Self-diagnostic output pin 2.
5	GND2	GND pin 2.
6	OUT2	Output pin 2, when output pin shorted to battery and output current exceeding the over current detection value, output current will be limited to protect IC.
7	GND1	GND pin 1.
8	OUT1	Output pin 1. When output pin shorted to battery and output current exceeding the over current detection value, output current will be limited to protect IC.

(Note 1) The number in Pin Name is the channel number.

Term

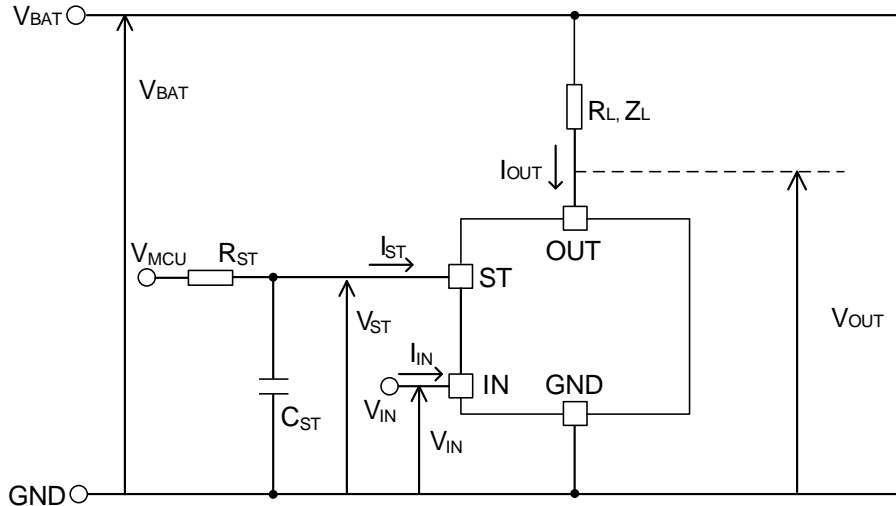

Figure 3. Term

Absolute Maximum Ratings(Tj = 25°C)

Parameter	Symbol	Ratings	Unit
Output Voltage	V _{OUT}	-0.3 to +42	V
Input Voltage	V _{IN}	-0.3 to +7	V
Output Current	I _{OUT(OCF)}	1.7 (inside limited) ^(Note 1)	A
Diagnostic Output Voltage	V _{ST}	-0.3 to +7	V
Diagnostic Output Current	I _{ST}	10	mA
Active Clamp Energy (Single Pulse) T _{j(START)} = 25 °C ^(Note 2)	E _{AS(25 °C)}	300	mJ
Active Clamp Energy (Single Pulse) T _{j(START)} = 150 °C ^{(Note 2) (Note 3)}	E _{AS(150 °C)}	60	
Operating Temperature Range	T _j	-40 to +150	°C
Storage Temperature Range	T _{stg}	-55 to +150	°C
Maximum Junction Temperature	T _{jmax}	150	°C

Caution 1: Operating the IC over the absolute maximum ratings may damage the IC. The damage can either be a short circuit between pins or an open circuit between pins and the internal circuitry. Therefore, it is important to consider circuit protection measures, such as adding a fuse, in case the IC is operated over the absolute maximum ratings.

Caution 2: Should by any chance the maximum junction temperature rating be exceeded the rise in temperature of the chip may result in deterioration of the properties of the chip. In case of exceeding this absolute maximum rating, design a PCB boards with thermal resistance taken into consideration by increasing board size and copper area so as not to exceed the maximum junction temperature rating.

(Note 1) Internally limited by over current protection function.

(Note 2) Active clamp energy (Single Pulse), at the condition I_{OUT(START)} = 0.5 A, V_{BAT} = 16 V.

$$E_{AS} = \frac{1}{2} I_{OUT(START)}^2 \times \left(1 - \frac{V_{BAT}}{V_{BAT} - V_{OUT(CL)}} \right)$$

(Note 3) Not 100 % tested.

Recommended Operating Conditions

Parameter	Symbol	Min	Typ	Max	Unit
Input Voltage	V _{IN}	3.0	5.0	5.5	V
Operating Temperature	T _j	-40	+25	+150	°C

Thermal Resistance^(Note 1)

Parameter	Symbol	Typ	Unit	Condition
BV1LC300FJ-C				
Between Junction and Surroundings Temperature Thermal Resistance	θ_{JA}	143.7	°C/W	1s ^(Note 2)
		86.9	°C/W	2s ^(Note 3)
		67.5	°C/W	2s2p ^(Note 4)

Parameter	Symbol	Typ	Unit	Condition
BM2LC300FJ-C (1ch ON)				
Between Junction and Surroundings Temperature Thermal Resistance	θ_{JA}	173.3	°C/W	1s ^(Note 2)
		112.5	°C/W	2s ^(Note 3)
		91.2	°C/W	2s2p ^(Note 4)

Parameter	Symbol	Typ	Unit	Condition
BM2LC300FJ-C (All ch ON)				
Between Junction and Surroundings Temperature Thermal Resistance	θ_{JA}	146.2	°C/W	1s ^(Note 2)
		88.5	°C/W	2s ^(Note 3)
		71.4	°C/W	2s2p ^(Note 4)

(Note 1) The thermal impedance is based on JESD51-2A (Still-Air) standard. They are used the chip of BV1LC300FJ-C and the chip of BM2LC300FJ-C.

(Note 2) JESD51-3 standard FR4 114.3 mm x 76.2 mm x 1.57 mm 1-layer (1s)
(Top copper foil: ROHM recommended Footprint + wiring to measure, 2 oz. copper.)

(Note 3) JESD51-5 standard FR4 114.3 mm x 76.2 mm x 1.60 mm 2-layers (2s)
(Top copper foil: ROHM recommended Footprint + wiring to measure/
Copper foil area on the reverse side of PCB: 74.2 mm x 74.2 mm,
copper (top & reverse side) 2 oz.)

(Note 4) JESD51-5/-7 standard FR4 114.3 mm x 76.2 mm x 1.60 mm 4-layers (2s2p)
(Top copper foil: ROHM recommended Footprint + wiring to measure/
2 inner layers and copper foil area on the reverse side of PCB: 74.2 mm x 74.2 mm,
copper (top & reverse side/inner layers) 2 oz./1 oz.)

■ PCB Layout 1 layer (1s)

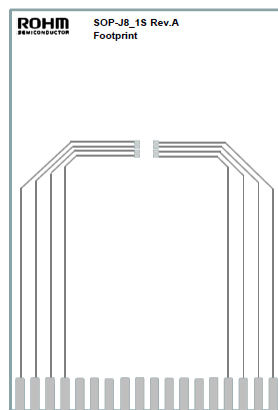

Footprint

Figure 4. PCB Layout 1 layer (1s)

Dimension	Value
Board Finish Thickness	1.57 mm ± 10 %
Board Dimension	76.2 mm x 114.3 mm
Board Material	FR4
Copper Thickness (Top Layer)	0.070 mm (Cu:2 oz)

Thermal Resistance – continued

- PCB Layout 2 layers (2s)

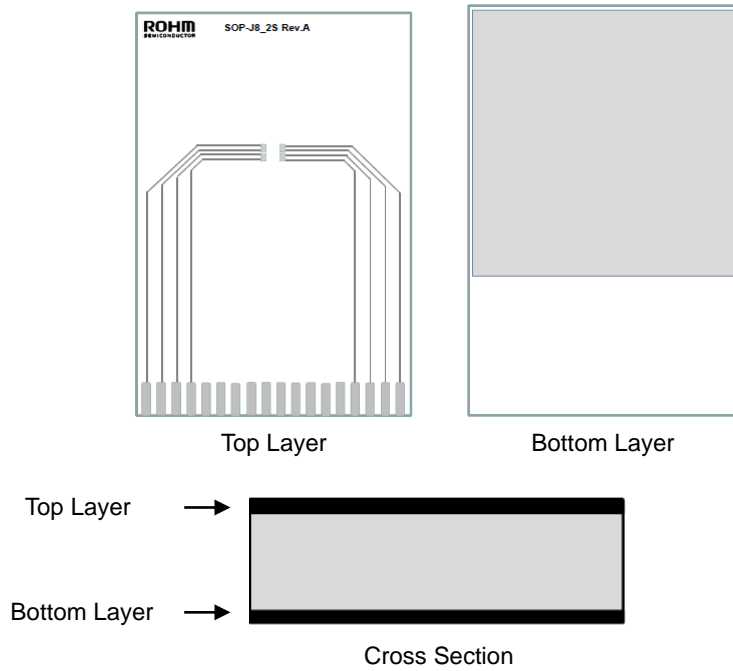

Figure 5. PCB Layout 2 layers (2s)

Dimension	Value
Board Finish Thickness	1.60 mm ± 10 %
Board Dimension	76.2 mm x 114.3 mm
Board Material	FR4
Copper Thickness (Top/Bottom Layers)	0.070 mm (Cu + Plating)

Thermal Resistance – continued

- PCB Layout 4 layers (2s2p)

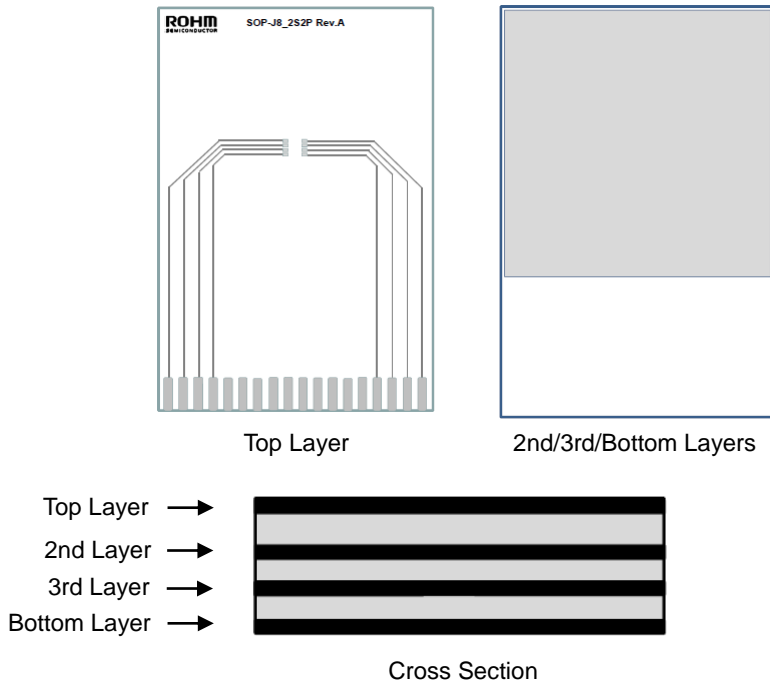

Figure 6. PCB Layout 4 layers (2s2p)

Dimension	Value
Board Finish Thickness	1.60 mm ± 10 %
Board Dimension	76.2 mm x 114.3 mm
Board Material	FR4
Copper Thickness (Top/Bottom Layers)	0.070 mm (Cu + Plating)
Copper Thickness (Inner Layers)	0.035 mm

- BV1LC300FJ-C Transient Thermal Resistance (Single Pulse)

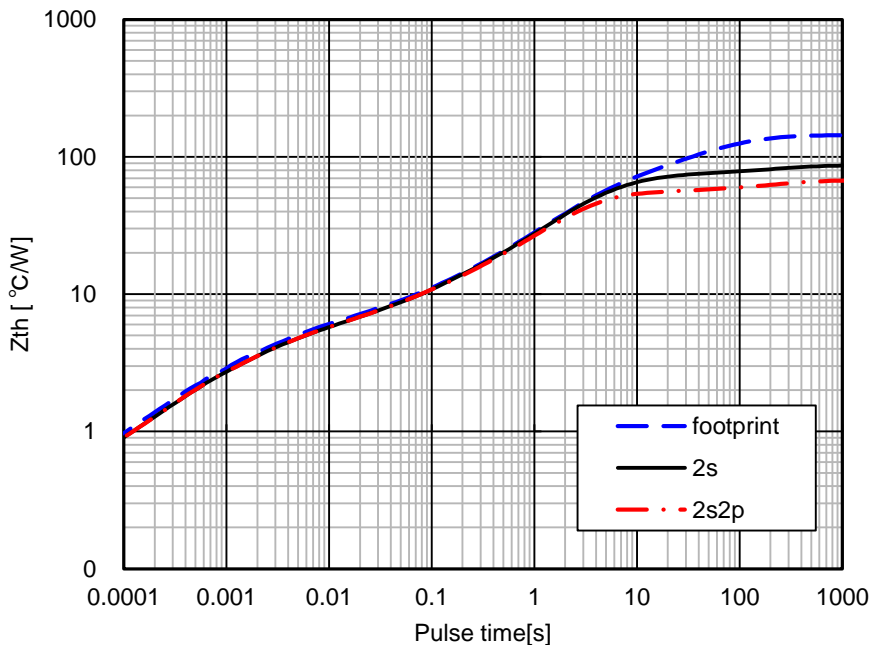

Figure 7. Transient Thermal Resistance

Thermal Resistance – continued

- BM2LC300FJ-C Transient Thermal Resistance (Single Pulse) 1ch ON

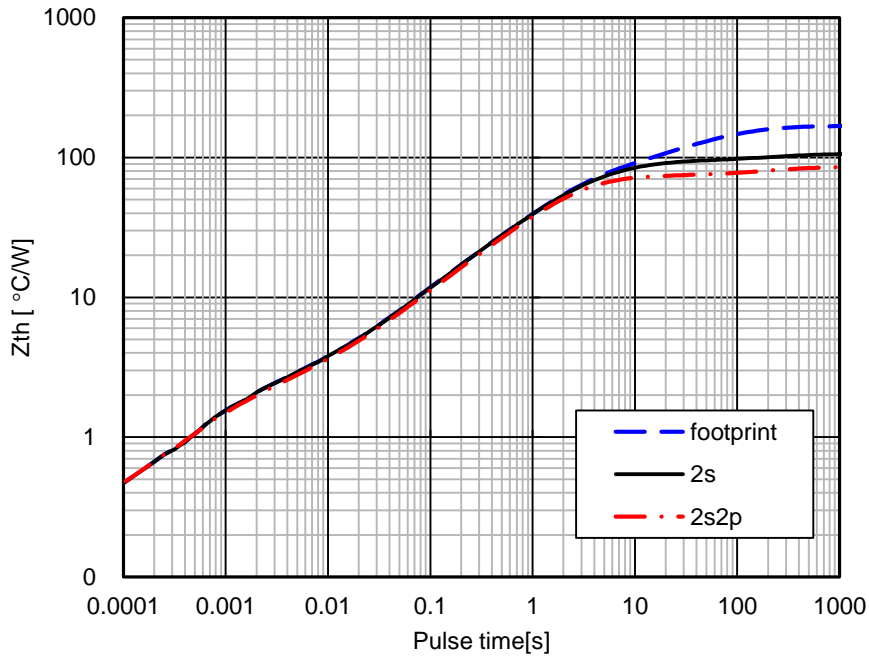

Figure 8. Transient Thermal Resistance

- BM2LC300FJ-C Transient Thermal Resistance (Single Pulse) All ch ON

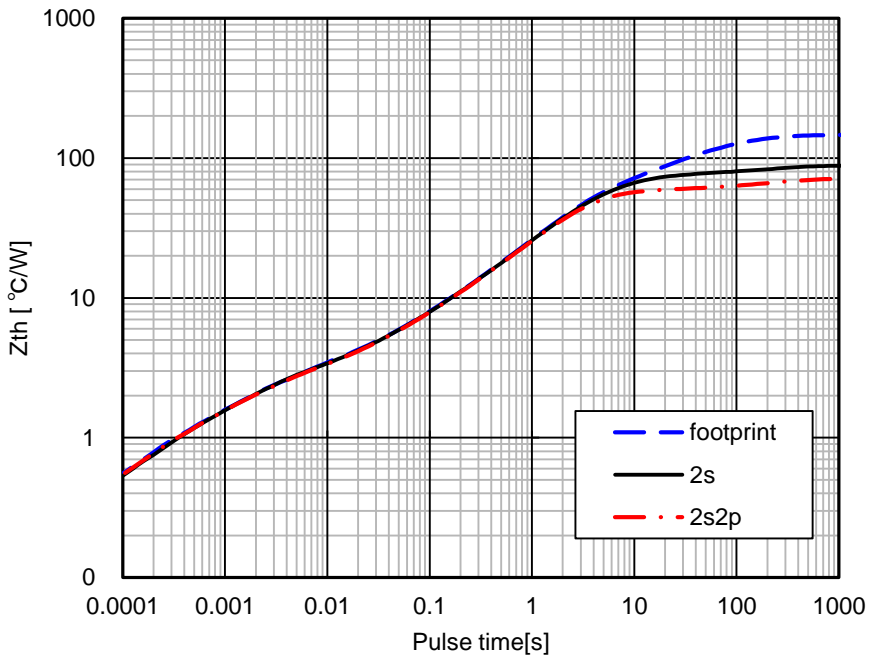

Figure 9. Transient Thermal Resistance

Electrical Characteristics (Unless otherwise specified, $-40\text{ °C} \leq T_j \leq +150\text{ °C}$)

Parameter	Symbol	Limit			Unit	Conditions
		Min	Typ	Max		
Output Clamp Voltage	$V_{OUT(CL)}$	42	48	54	V	$V_{IN} = 0\text{ V}$, $I_{OUT} = 1\text{ mA}$
On-state Resistance ($V_{IN} = 5\text{ V}$, $T_j = 25\text{ °C}$)	$R_{DS(ON)}$	-	350	435	m Ω	$V_{IN} = 5\text{ V}$, $I_{OUT} = 0.5\text{ A}$, $T_j = 25\text{ °C}$
On-state Resistance ($V_{IN} = 5\text{ V}$, $T_j = 150\text{ °C}$)	$R_{DS(ON)}$	-	660	850	m Ω	$V_{IN} = 5\text{ V}$, $I_{OUT} = 0.5\text{ A}$, $T_j = 150\text{ °C}$
On-state Resistance ($V_{IN} = 3\text{ V}$, $T_j = 25\text{ °C}$)	$R_{DS(ON)}$	-	460	595	m Ω	$V_{IN} = 3\text{ V}$, $I_{OUT} = 0.5\text{ A}$, $T_j = 25\text{ °C}$
On-state Resistance ($V_{IN} = 3\text{ V}$, $T_j = 150\text{ °C}$)	$R_{DS(ON)}$	-	845	1100	m Ω	$V_{IN} = 3\text{ V}$, $I_{OUT} = 0.5\text{ A}$, $T_j = 150\text{ °C}$
Leak Current ($T_j = 25\text{ °C}$)	$I_{OUT(L)}$	40	60	80	μA	$V_{IN} = 0\text{ V}$, $V_{OUT} = 18\text{ V}$, $T_j = 25\text{ °C}$
Leak Current ($T_j = 150\text{ °C}$)	$I_{OUT(L)}$	50	85	200	μA	$V_{IN} = 0\text{ V}$, $V_{OUT} = 18\text{ V}$, $T_j = 150\text{ °C}$
Turn-ON TIME	t_{ON}	-	-	40	μs	$V_{IN} = 0\text{ V}$ to 5 V , $R_L = 15\ \Omega$, $V_{BAT} = 12\text{ V}$, $T_j = 25\text{ °C}$
Turn-OFF TIME	t_{OFF}	-	-	40	μs	$V_{IN} = 5\text{ V}$ to 0 V , $R_L = 15\ \Omega$, $V_{BAT} = 12\text{ V}$, $T_j = 25\text{ °C}$
Slew Rate On	SR_{ON}	-	1.5	3.0	V/ μs	$V_{IN} = 0\text{ V}$ to 5 V , $R_L = 15\ \Omega$, $V_{BAT} = 12\text{ V}$, $T_j = 25\text{ °C}$
Slew Rate Off	SR_{OFF}	-	3.0	6.0	V/ μs	$V_{IN} = 5\text{ V}$ to 0 V , $R_L = 15\ \Omega$, $V_{BAT} = 12\text{ V}$, $T_j = 25\text{ °C}$
Input Threshold Voltage	$V_{IN(TH)}$	1.5	-	2.7	V	$R_L = 15\ \Omega$, $V_{BAT} = 12\text{ V}$
High-level Input Current1 (in Normal Operation)	$I_{IN(H1)}$	-	110	220	μA	$V_{IN} = 5\text{ V}$
High-level Input Current2 (in Abnormal Operation) ^(Note 1)	$I_{IN(H2)}$	-	-	500	μA	$V_{IN} = 5\text{ V}$
Low-level Input Current	$I_{IN(L)}$	-10	0	+10	μA	$V_{IN} = 0\text{ V}$
Over Current Detection Current	$I_{OUT(OCF)}$	1.7	2.7	3.7	A	$V_{IN} = 5\text{ V}$, $V_{BAT} = 12\text{ V}$, $T_j = 25\text{ °C}$
Thermal Shutdown Operated Temperature ^(Note 2)	T_{jo}	150	175	-	$^{\circ}\text{C}$	$V_{IN} = 5\text{ V}$
Thermal Shutdown Released Temperature ^(Note 2)	T_{jr}	135	-	-	$^{\circ}\text{C}$	$V_{IN} = 5\text{ V}$
Thermal Shutdown Hysteresis ^(Note 2)	$T_{j\Delta HYS}$	-	15	-	$^{\circ}\text{C}$	$V_{IN} = 5\text{ V}$

(Note 1) When thermal shutdown function or over current protection function is ON.

(Note 2) Not 100 % tested.

Electrical Characteristics (Unless otherwise specified, $-40\text{ }^{\circ}\text{C} \leq T_j \leq +150\text{ }^{\circ}\text{C}$) – continued

Parameter	Symbol	Limit			Unit	Conditions
		Min	Typ	Max		
Open Load Detection Voltage	V_{OPEN}	1.5	-	4.5	V	$V_{\text{IN}} = 0\text{ V}$
ST Output On Voltage1	$V_{\text{ST(ON1)}}$	-	0.2	0.5	V	$V_{\text{IN}} = 5\text{ V}$, $I_{\text{ST}} = 1\text{ mA}$
ST Output On Voltage2	$V_{\text{ST(ON2)}}$	-	0.2	0.5	V	$V_{\text{IN}} = 0\text{ V}$, $V_{\text{OUT}} = 4.5\text{ V}$, $I_{\text{ST}} = 0.5\text{ mA}$
ST Output Leak Current1	$I_{\text{ST(L1)}}$	-	-	20	μA	$V_{\text{IN}} = 5\text{ V}$, $V_{\text{ST}} = 5\text{ V}$
ST Output Leak Current2	$I_{\text{ST(L2)}}$	-	-	20	μA	$V_{\text{IN}} = 0\text{ V}$, $V_{\text{OUT}} = 1.5\text{ V}$, $V_{\text{ST}} = 5\text{ V}$
ST Output Delay Time Detect	t_{STDET}	-	1	30	μs	$V_{\text{IN}} = 0\text{ V}$, $V_{\text{OUT}} = 5\text{ V to } 1\text{ V}$, $V_{\text{MCU}} = 5\text{ V}$, $R_{\text{ST}} = 10\text{ k}\Omega$, $C_{\text{ST}} = 10\text{ pF}$
ST Output Delay Time Release	t_{STREL}	-	1	30	μs	$V_{\text{IN}} = 0\text{ V}$, $V_{\text{OUT}} = 1\text{ V to } 5\text{ V}$, $V_{\text{MCU}} = 5\text{ V}$, $R_{\text{ST}} = 10\text{ k}\Omega$, $C_{\text{ST}} = 10\text{ pF}$

Typical Performance Curves(Unless otherwise specified, $T_j = 25\text{ }^\circ\text{C}$, $V_{IN} = 5.0\text{ V}$)

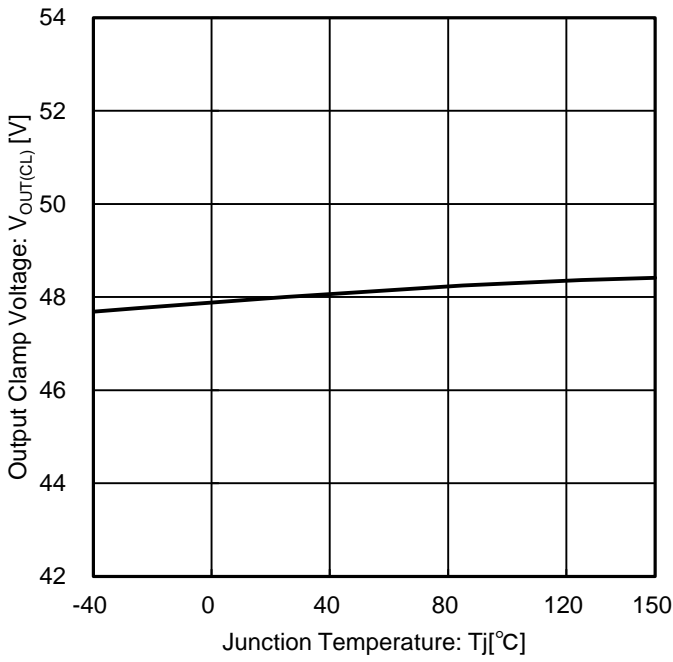

Figure 10. Output Clamp Voltage vs Junction Temperature

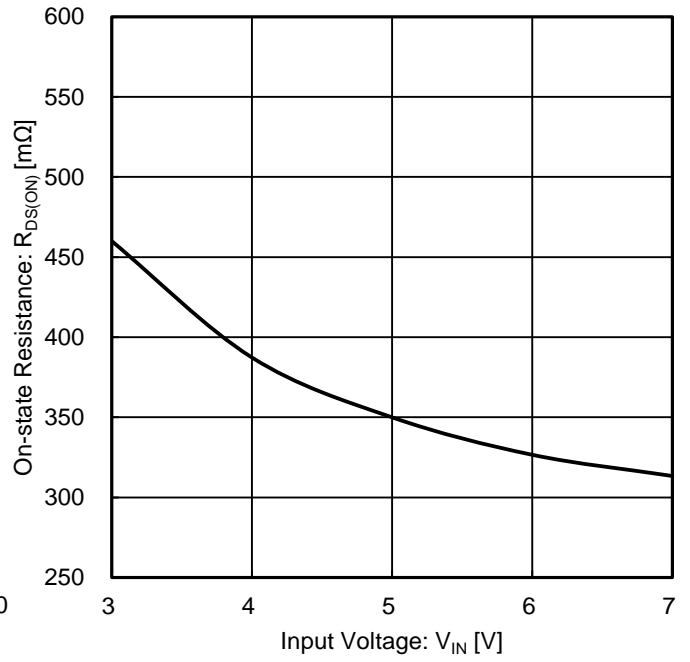

Figure 11. On-state Resistance vs Input Voltage

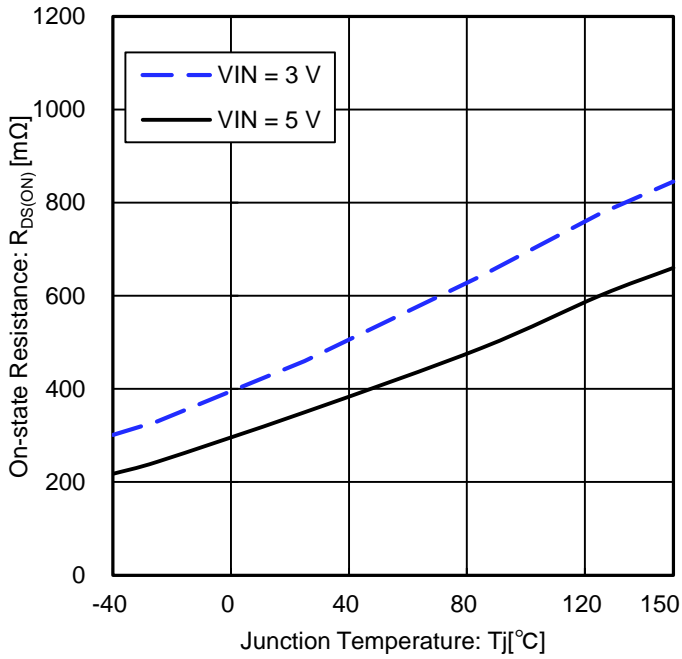

Figure 12. On-state Resistance vs Junction Temperature

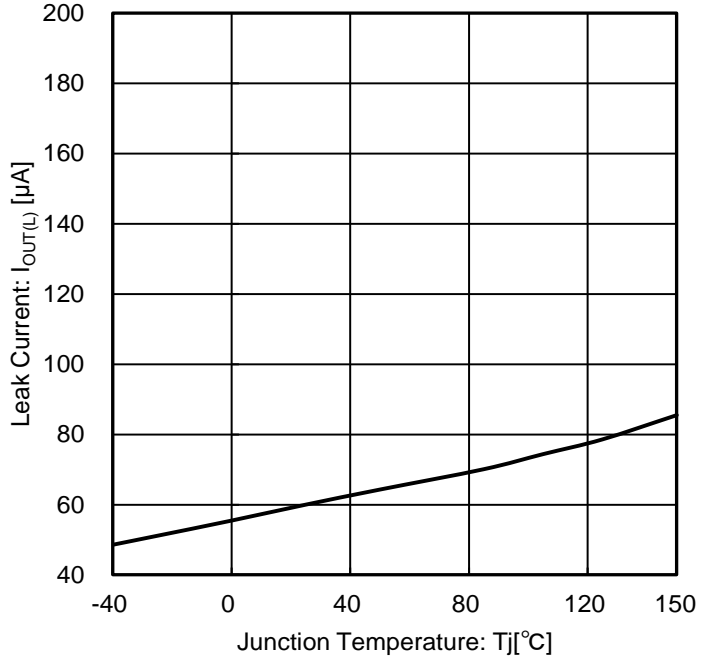

Figure 13. Leak Current vs Junction Temperature

Typical Performance Curves (Unless otherwise specified, $T_j = 25\text{ }^\circ\text{C}$, $V_{IN} = 5.0\text{ V}$) – continued

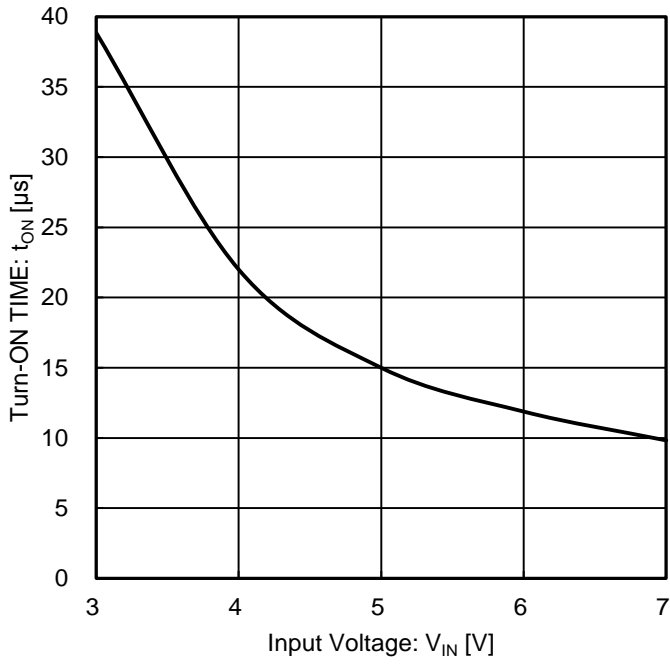

Figure 14. Turn-ON TIME vs Input Voltage

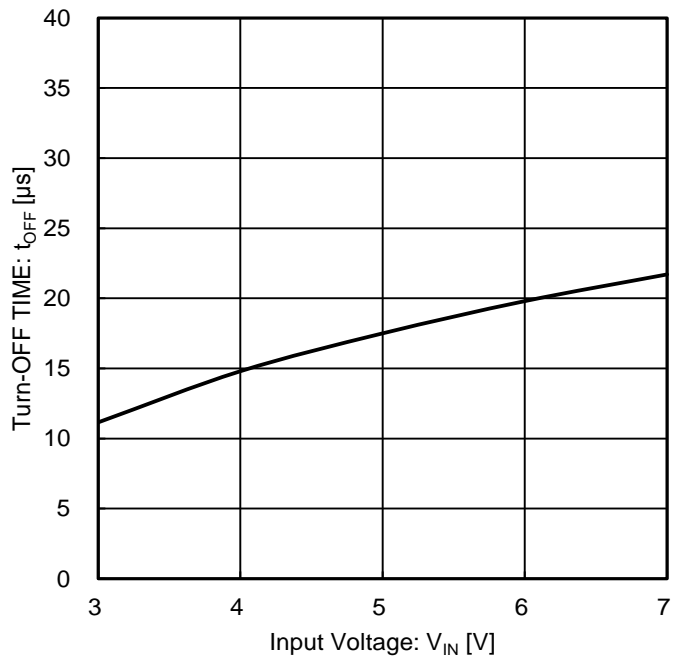

Figure 15. Turn-OFF TIME vs Input Voltage

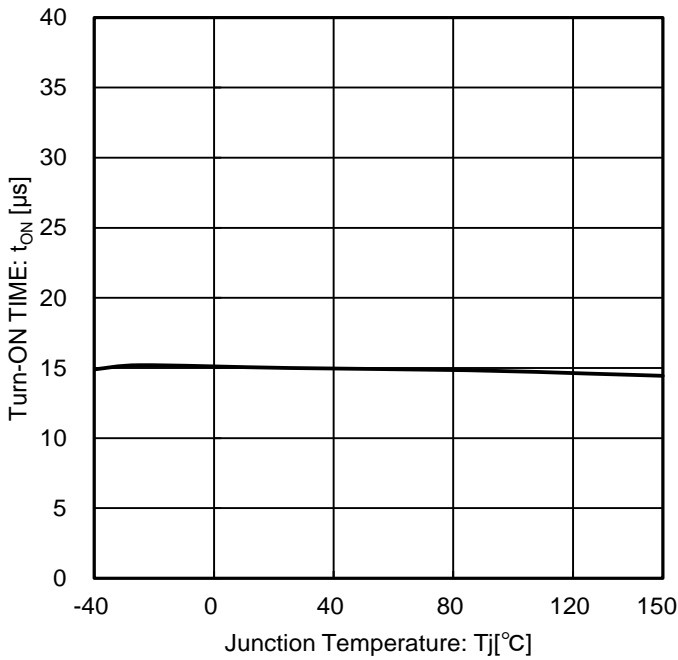

Figure 16. Turn-ON TIME vs Junction Temperature

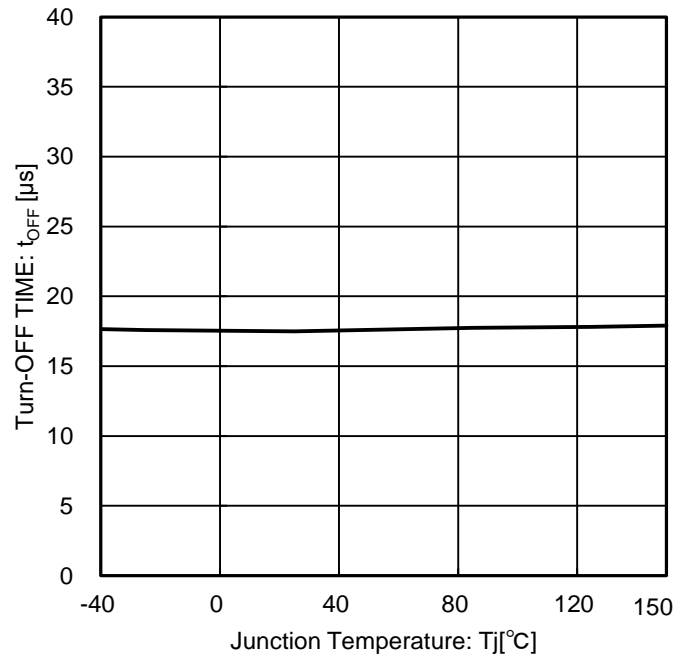

Figure 17. Turn-OFF TIME vs Junction Temperature

Typical Performance Curves (Unless otherwise specified, $T_j = 25\text{ }^\circ\text{C}$, $V_{IN} = 5.0\text{ V}$) – continued

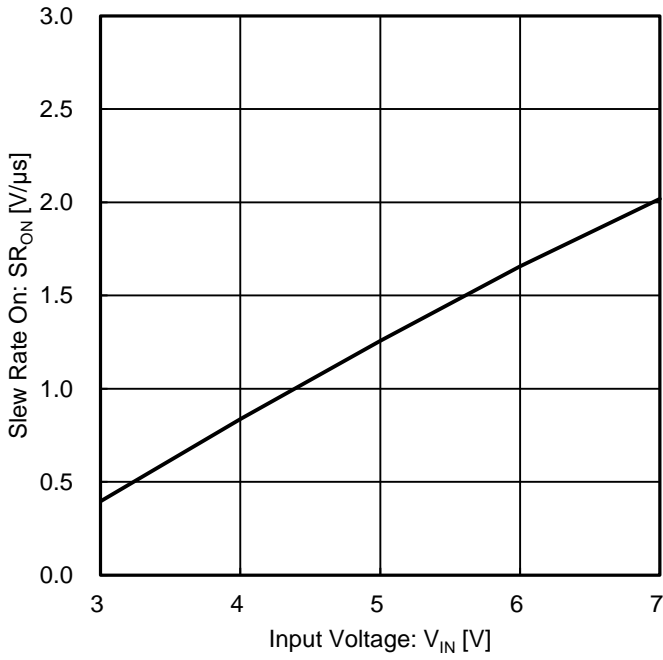

Figure 18. Slew Rate On vs Input Voltage

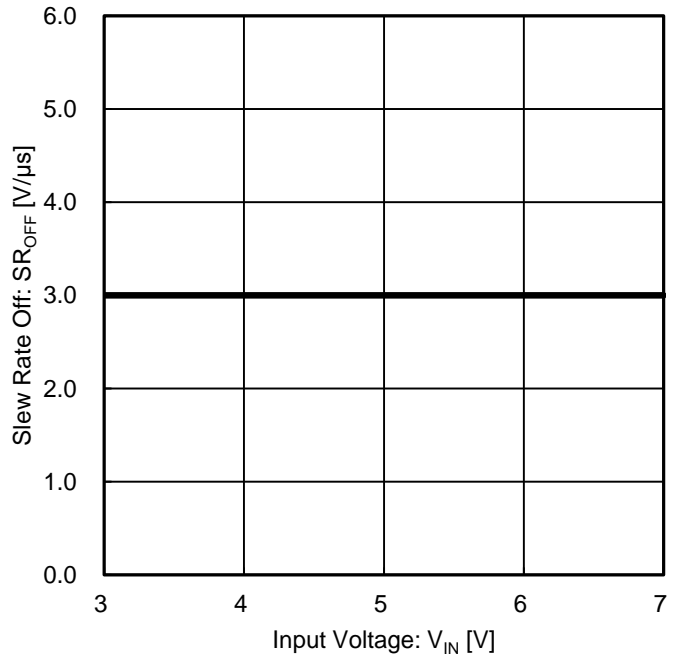

Figure 19. Slew Rate Off vs Input Voltage

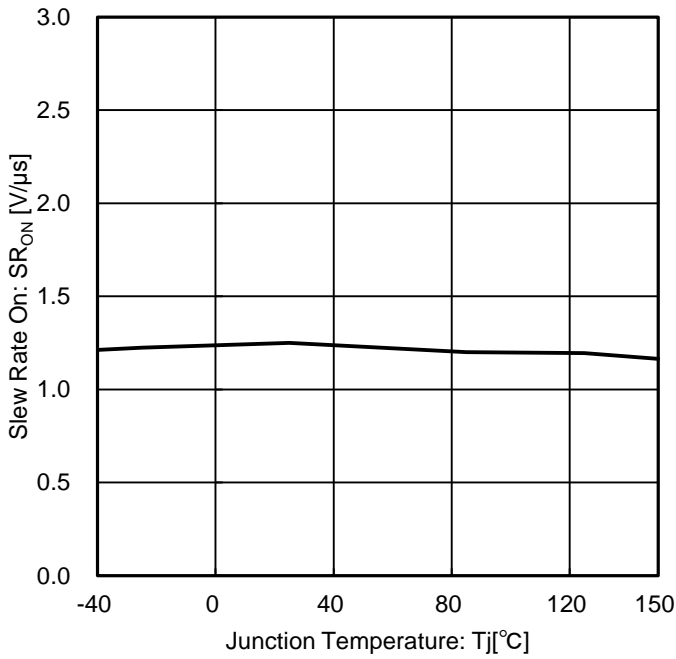

Figure 20. Slew Rate On vs Junction Temperature

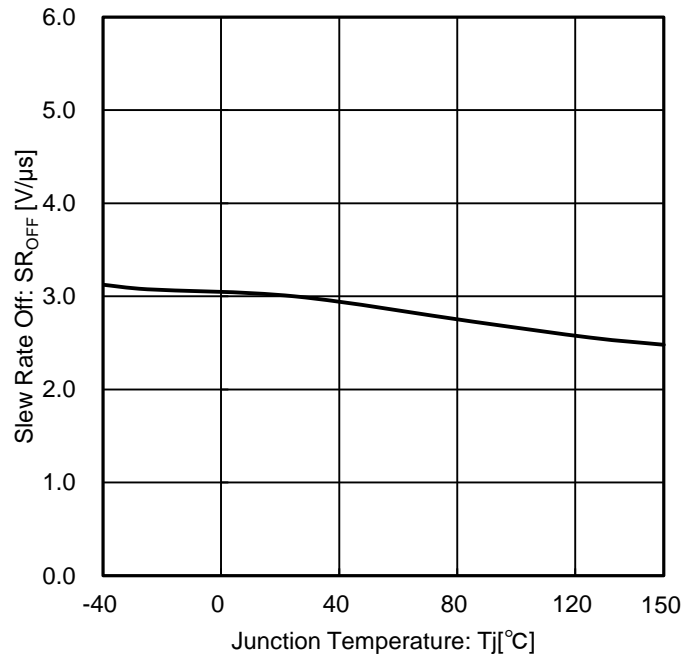

Figure 21. Slew Rate off vs Junction Temperature

Typical Performance Curves (Unless otherwise specified, $T_j = 25\text{ }^\circ\text{C}$, $V_{IN} = 5.0\text{ V}$) – continued

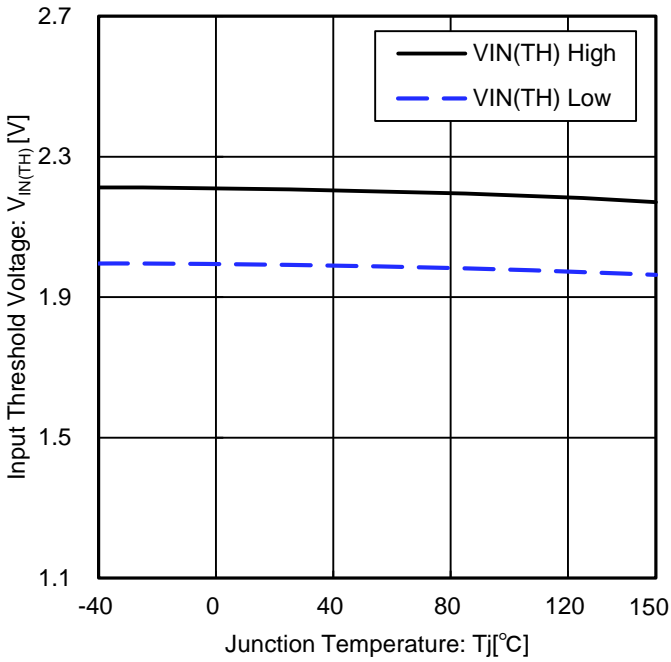

Figure 22. Input Threshold Voltage vs Junction Temperature

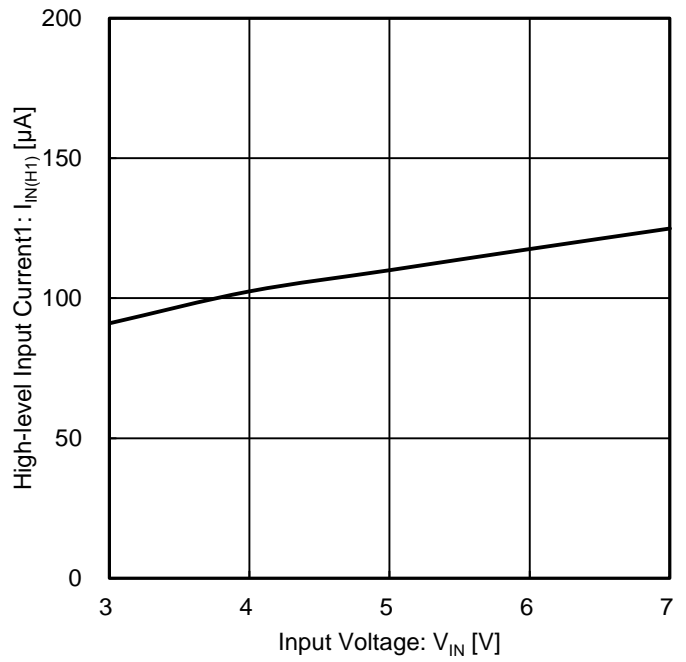

Figure 23. High-level Input Current1 (In Normal Operation) vs Input Voltage

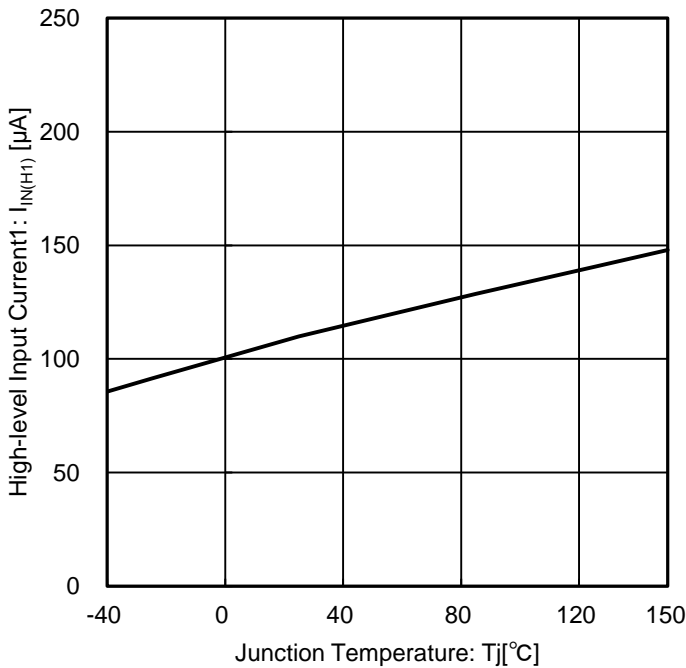

Figure 24. High-level Input Current1 (in Normal Operation) vs Junction Temperature

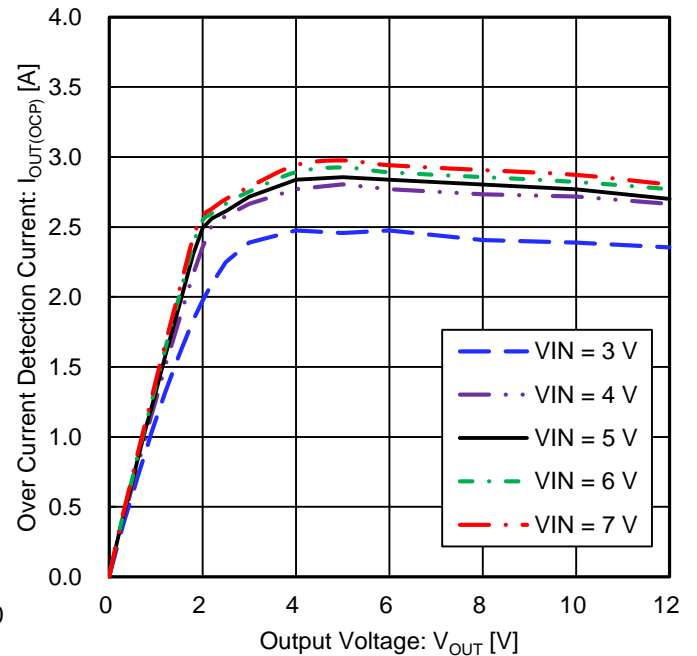

Figure 25. Over Current Detection Current vs Output Voltage

Typical Performance Curves (Unless otherwise specified, $T_j = 25\text{ }^\circ\text{C}$, $V_{IN} = 5.0\text{ V}$) – continued

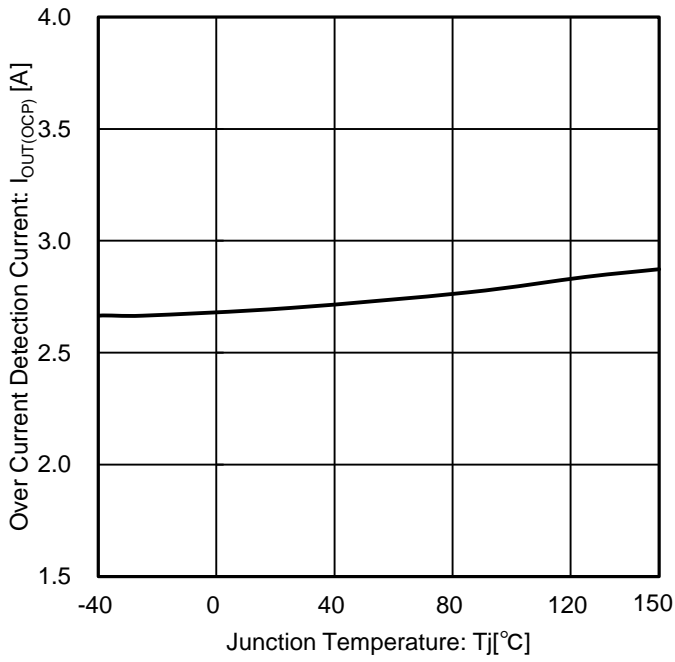

Figure 26. Over Current Detection Current vs Junction Temperature

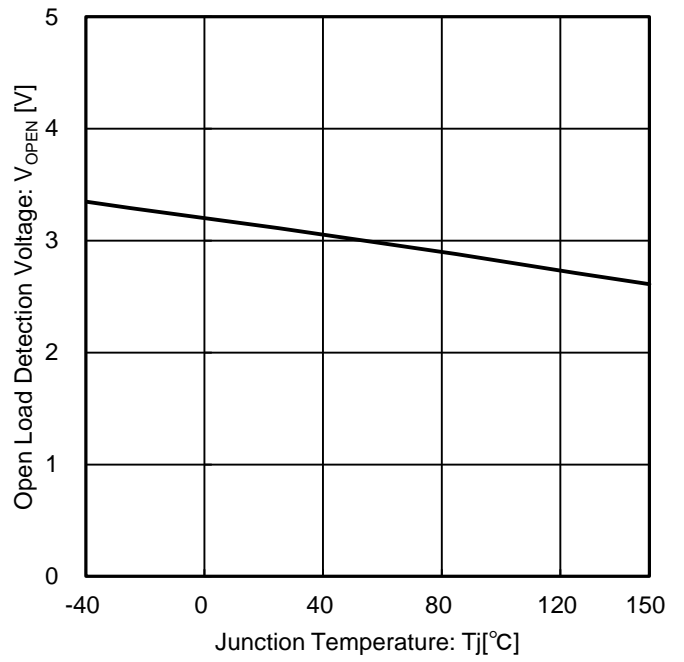

Figure 27. Open Load Detection Voltage vs Junction Temperature

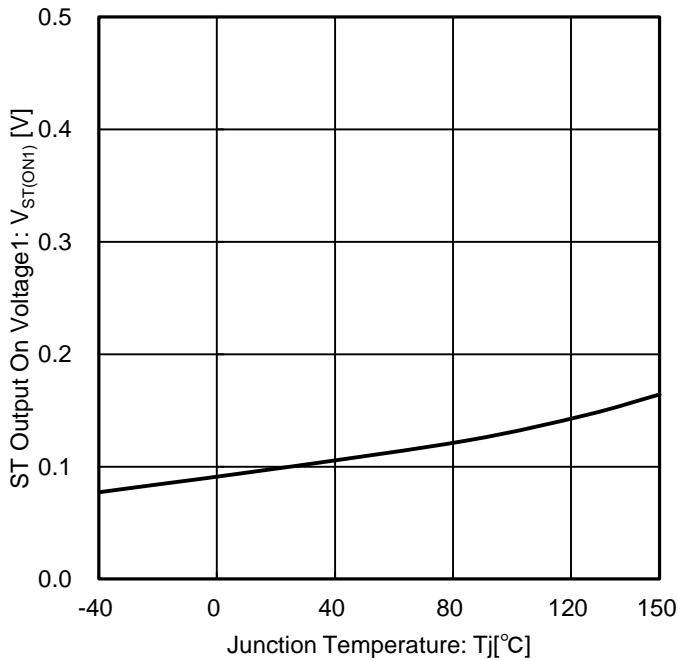

Figure 28. ST Output On Voltage1 vs Junction Temperature

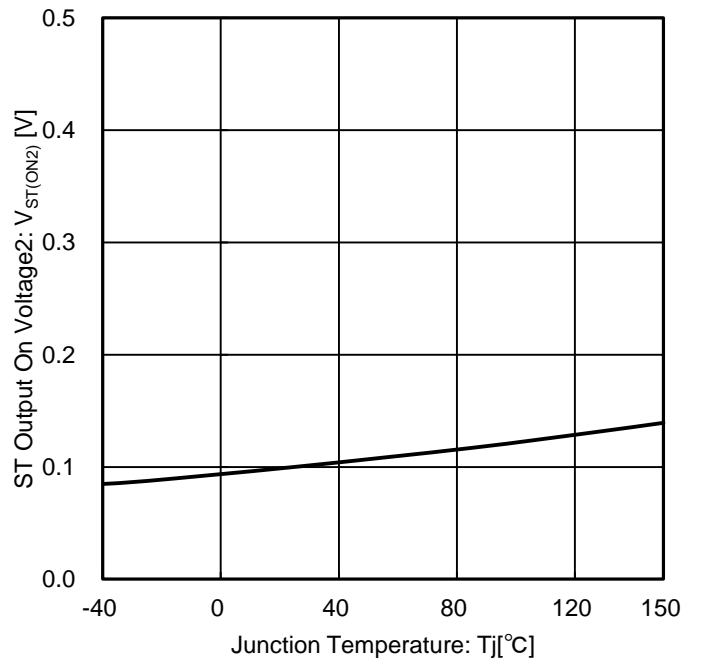

Figure 29. ST Output On Voltage2 vs Junction Temperature

Typical Performance Curves (Unless otherwise specified, $T_j = 25\text{ }^\circ\text{C}$, $V_{IN} = 5.0\text{ V}$) – continued

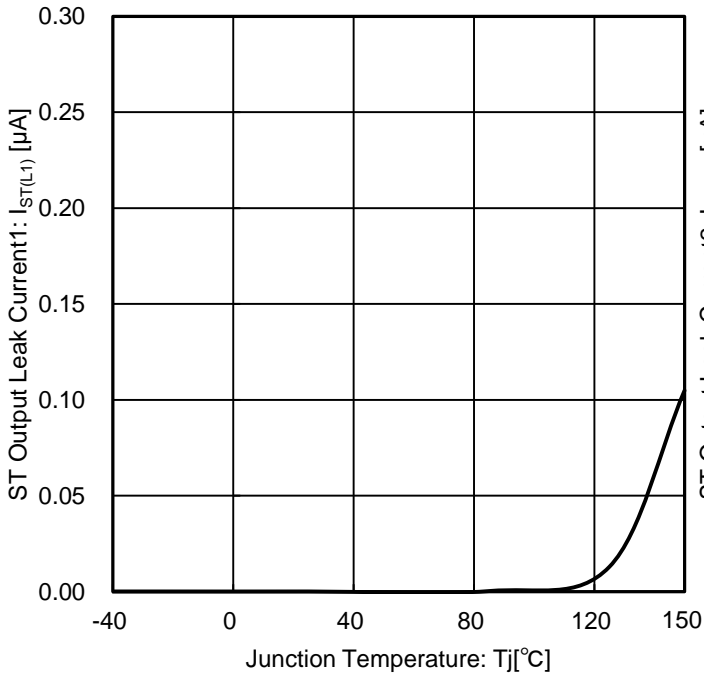

Figure 30. ST Output Leak Current1 vs Junction Temperature

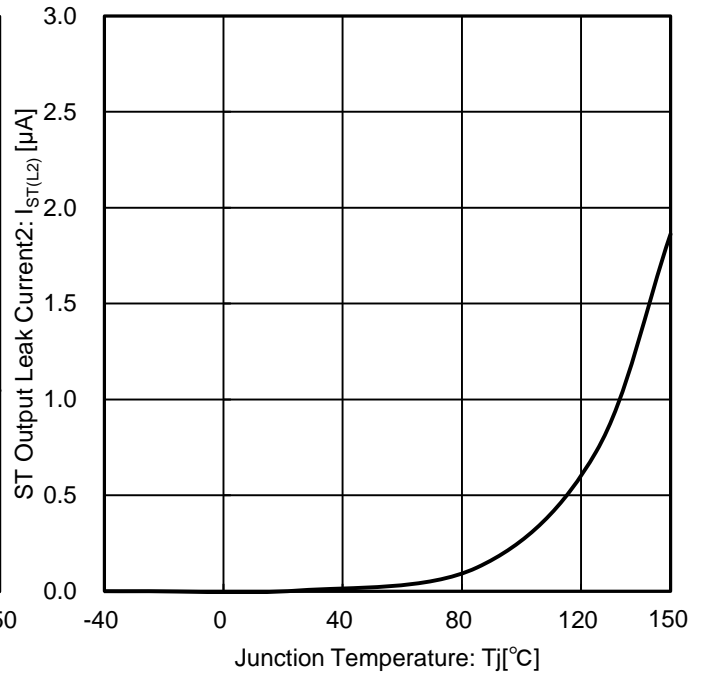

Figure 31. ST Output Leak Current2 vs Junction Temperature

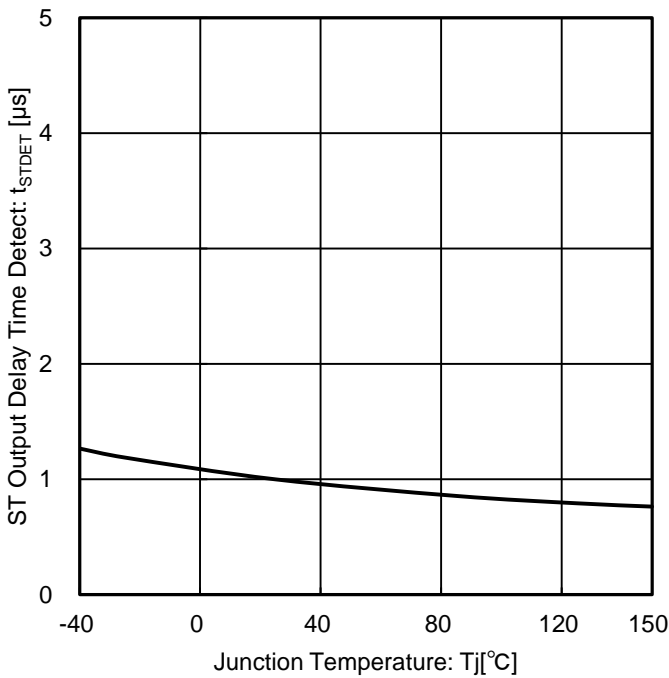

Figure 32. ST Output Delay Time Detect vs Junction Temperature

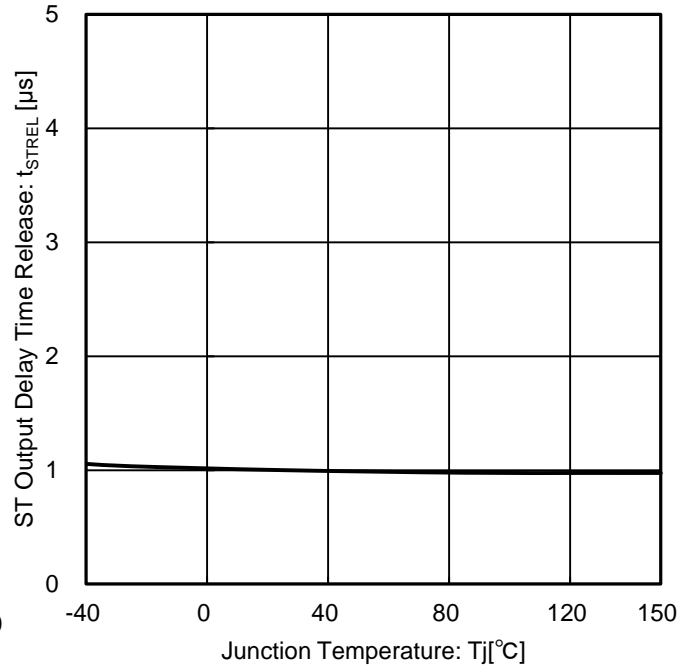

Figure 33. ST Output Delay Time Release vs Junction Temperature

Typical Performance Curves (Unless otherwise specified, $T_j = 25\text{ }^\circ\text{C}$, $V_{IN} = 5.0\text{ V}$) – continued

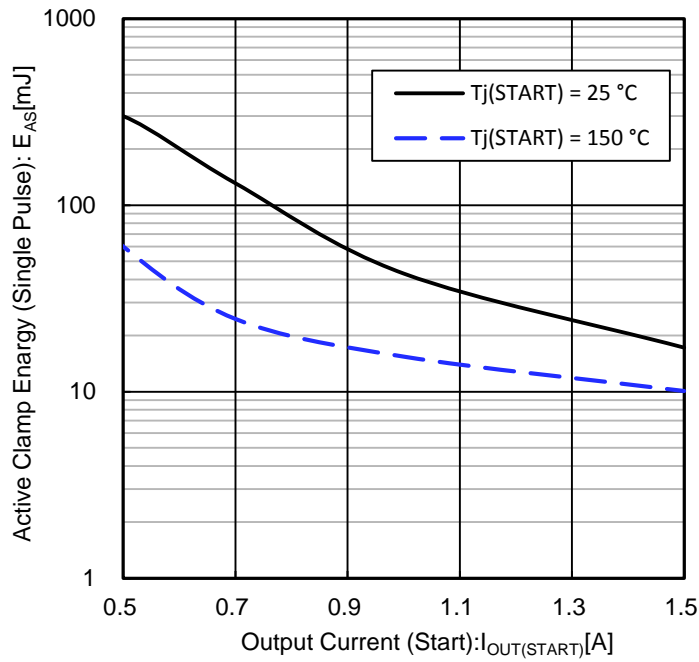
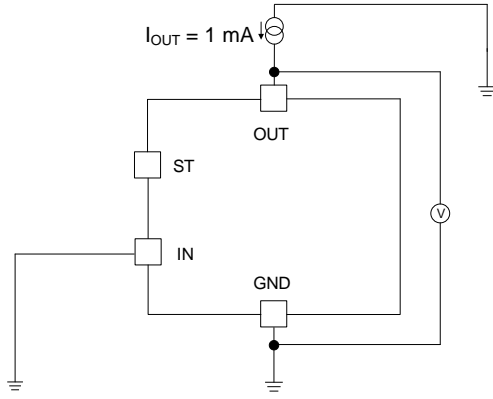
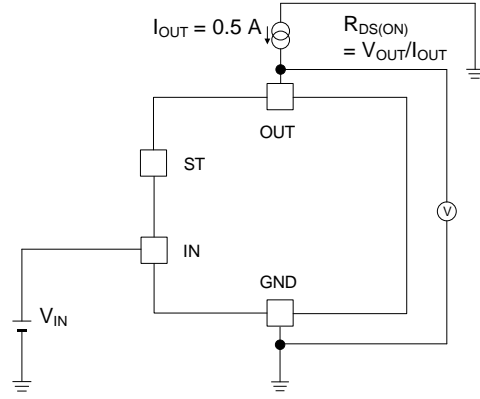

Figure 34. Active Clamp Energy (Single Pulse) vs Output Current (Start)

Measurement Circuit for Typical Performance Curves



Measurement Circuit for Figure 10



Measurement Circuit for Figure 11,12

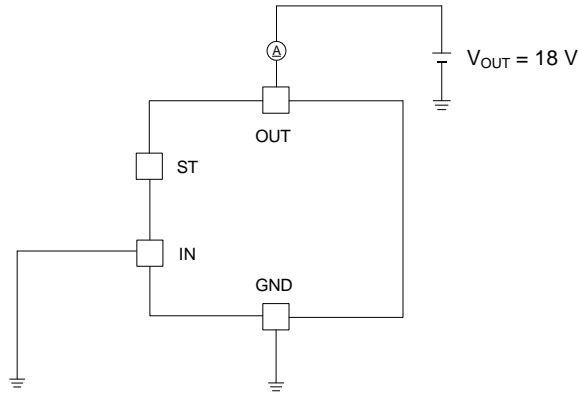

Measurement Circuit for Figure 13

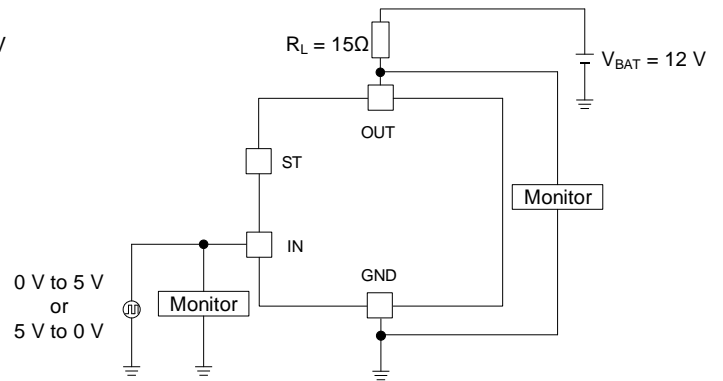

Measurement Circuit for Figure 14,15,16,17,18,19,20,21

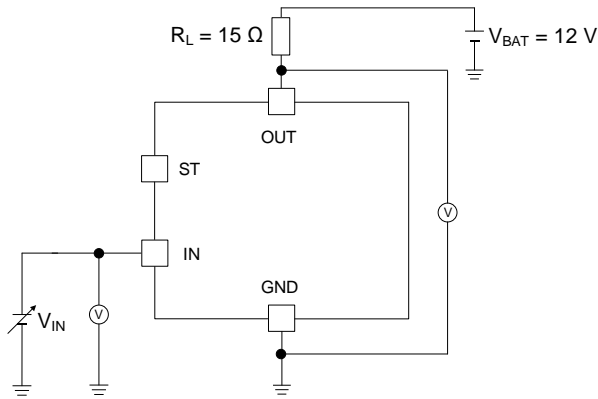

Measurement Circuit for Figure 22

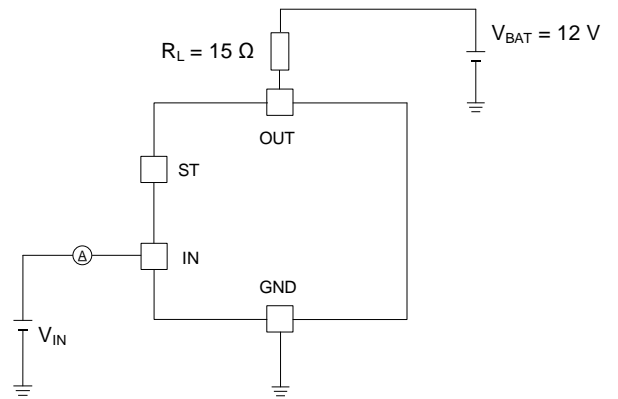

Measurement Circuit for Figure 23,24

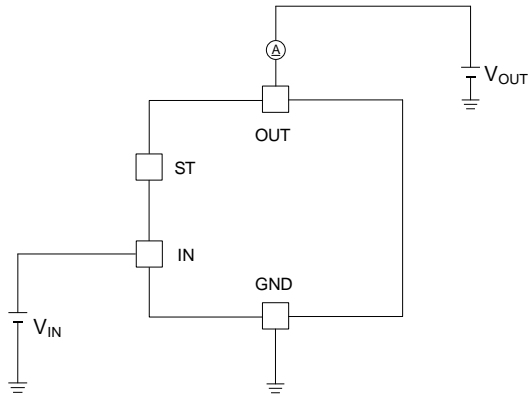

Measurement Circuit for Figure 25,26

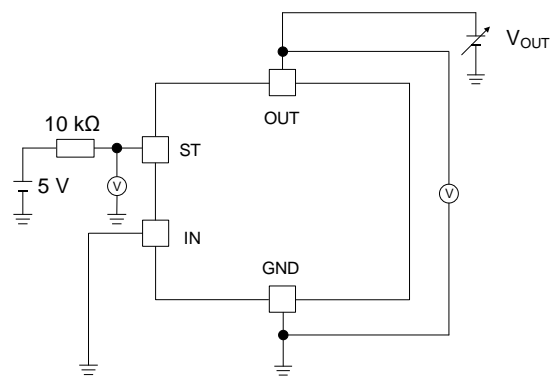

Measurement Circuit for Figure 27

Measurement Circuit for Typical Performance Curves – continued

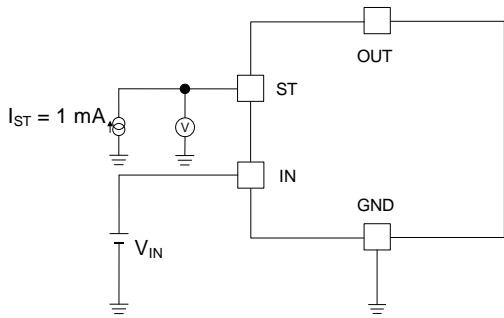

Measurement Circuit for Figure 28

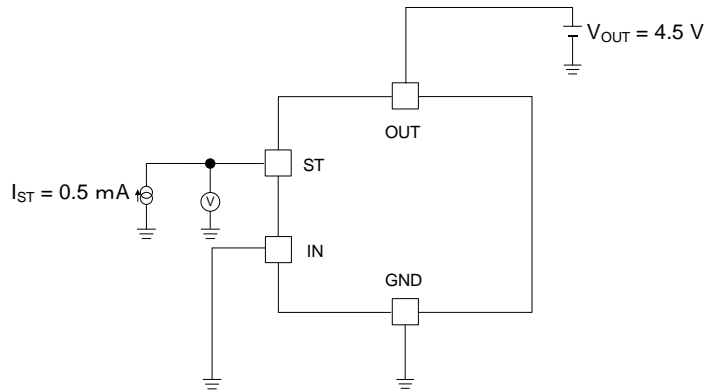

Measurement Circuit for Figure 29

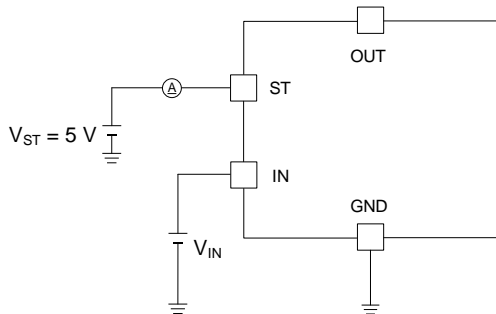

Measurement Circuit for Figure 30

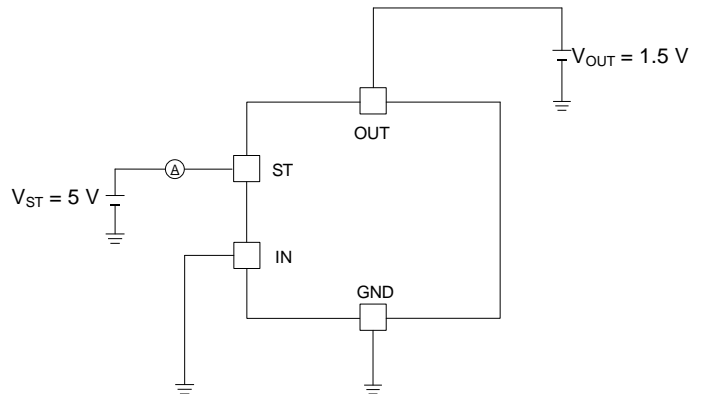

Measurement Circuit for Figure 31

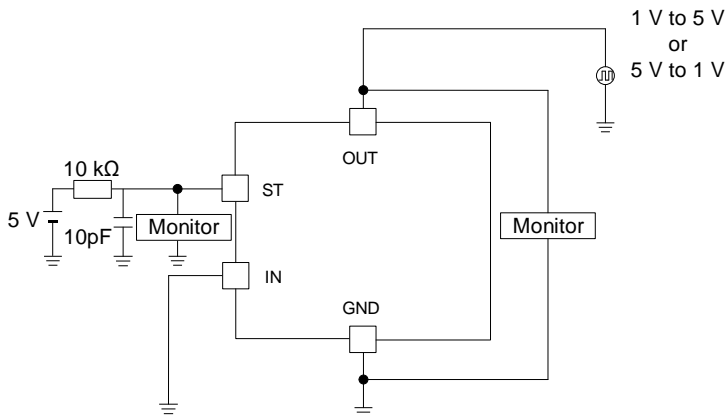

Measurement Circuit for Figure 32,33

I/O Pin Truth Table

■ Output Function

Input Signal	Operating Status	Output Status
L	Standby	OFF
H	Normal	ON
H	Over Current	Current Limiting
H	Over Temperature	OFF

■ Diagnostic Function of Abnormal Status

Diagnoses the presence or absence of an abnormal condition. By combining High and Low of the input signal and the ST pin, it is possible to grasp overcurrent, heating state, load open state.

Input Signal	ST Signal	Diagnosis Result
L	L	No Abnormality
L	H	Load Open
H	L	Over Current or Over Temperature
H	H	No Abnormality

Timing Chart

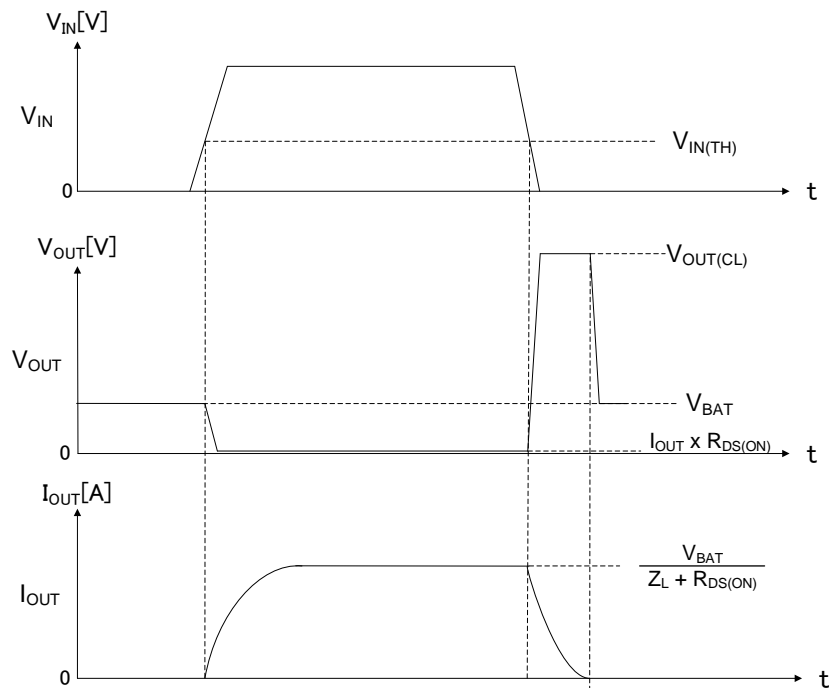

Figure 35. Inductive Load Operation

Timing Chart – continued

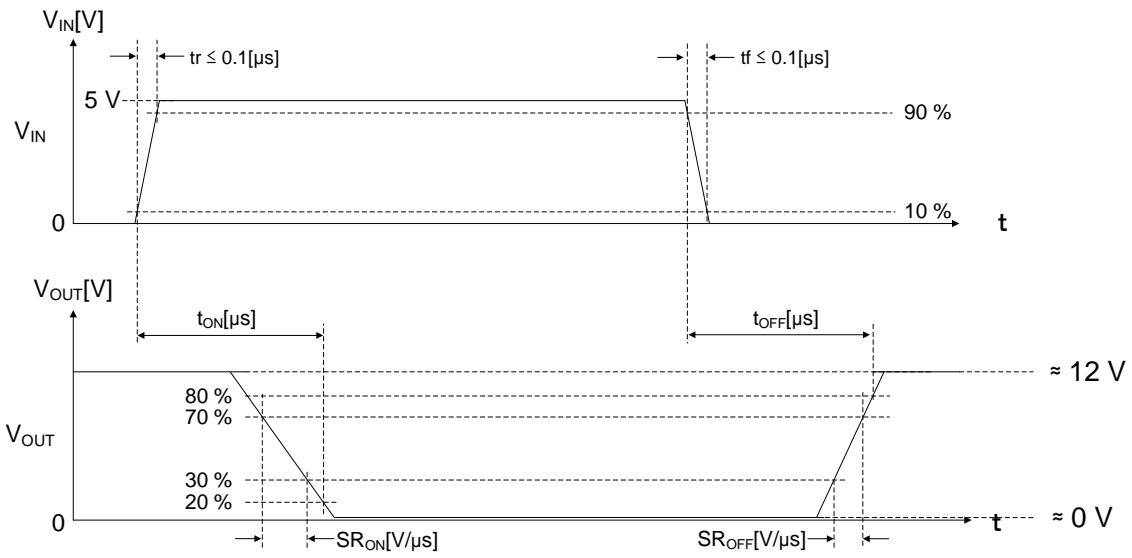

Figure 36. Switching Time

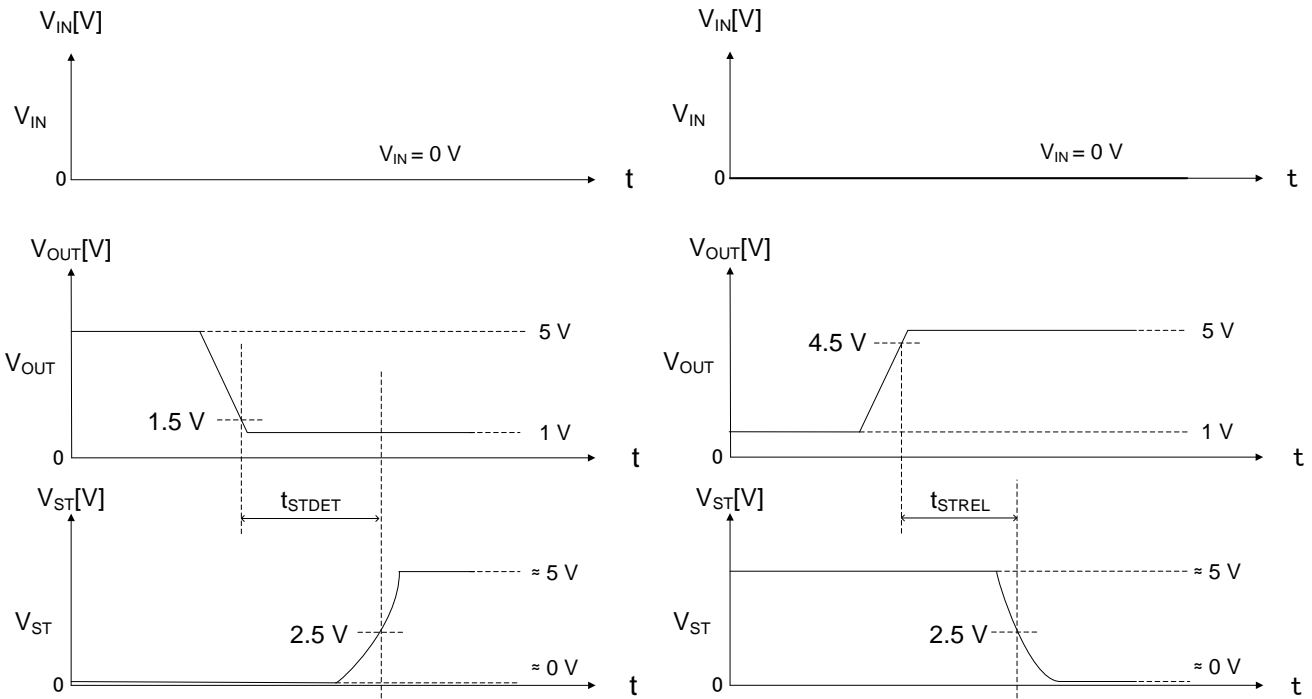

Figure 37. ST Output Delay Time

Operational Notes

1. Ground Voltage

Ensure that no pins are at a voltage below that of the ground pin at any time, even during transient condition.

2. Ground Wiring Pattern

When using both small-signal and large-current ground traces, the two ground traces should be routed separately but connected to a single ground at the reference point of the application board to avoid fluctuations in the small-signal ground caused by large currents. Also ensure that the ground traces of external components do not cause variations on the ground voltage. The ground lines must be as short and thick as possible to reduce line impedance.

3. Recommended Operating Conditions

The function and operation of the IC are guaranteed within the range specified by the recommended operating conditions. The characteristic values are guaranteed only under the conditions of each item specified by the electrical characteristics.

4. Testing on Application Boards

When testing the IC on an application board, connecting a capacitor directly to a low-impedance output pin may subject the IC to stress. Always discharge capacitors completely after each process or step. The IC's power supply should always be turned off completely before connecting or removing it from the test setup during the inspection process. To prevent damage from static discharge, ground the IC during assembly and use similar precautions during transport and storage.

5. Inter-pin Short and Mounting Errors

Ensure that the direction and position are correct when mounting the IC on the PCB. Incorrect mounting may result in damaging the IC. Avoid nearby pins being shorted to each other especially to ground, power supply and output pin. Inter-pin shorts could be due to many reasons such as metal particles, water droplets (in very humid environment) and unintentional solder bridge deposited in between pins during assembly to name a few.

6. Ceramic Capacitor

When using a ceramic capacitor, determine a capacitance value considering the change of capacitance with temperature and the decrease in nominal capacitance due to DC bias and others.

7. Thermal Shutdown Function (TSD)

This IC has a built-in thermal shutdown function that prevents heat damage to the IC. Normal operation should always be within the IC's maximum junction temperature rating. If however the rating is exceeded for a continued period, the junction temperature (T_j) will rise which will activate the TSD function that will turn OFF power output pins. When the T_j falls below the TSD threshold, the circuits are automatically restored to normal operation.

Note that the TSD function operates in a situation that exceeds the absolute maximum ratings and therefore, under no circumstances, should the TSD function be used in a set design or for any purpose other than protecting the IC from heat damage.

8. Over Current Protection Function (OCP)

This IC incorporates an integrated over current protection function that is activated when the load is shorted. This protection function is effective in preventing damage due to sudden and unexpected incidents. However, the IC should not be used in applications characterized by continuous operation or transitioning of the protection function.

9. Active Clamp Operation

The IC integrates the active clamp function to internally absorb the reverse energy which is generated when the inductive load is turned off. When the active clamp operates, the thermal shutdown function does not work. Please do not exceed active clamp endurance when inductive load is used.

Operational Notes – continued

10. Negative Current of Output

When supply a negative current from the OUT(DRAIN) pin in the state that supplied the voltage to the IN pin. The current pass from the IN pin to the OUT(DRAIN) pin through a parasitic transistor and voltage of the IN pin descend as shown in Figure 38 and Figure 39.

As shown in Figure 38 power MOS is turned on, set the OUT(DRAIN) pin is -0.3 V or higher. Because a negative current may be passed to the OUT(DRAIN) pin from a power supply of the connection of the IN pin (MCU, and so on).

As shown in Figure 39 power MOS is turned off, add a restriction resistance 330 Ω or higher to the IN pin. Because a negative current may be passed to the OUT(DRAIN) pin from GND of the connection of the IN pin. The restriction resistance value, set up in consideration of the voltage descent caused by the IN pin current.

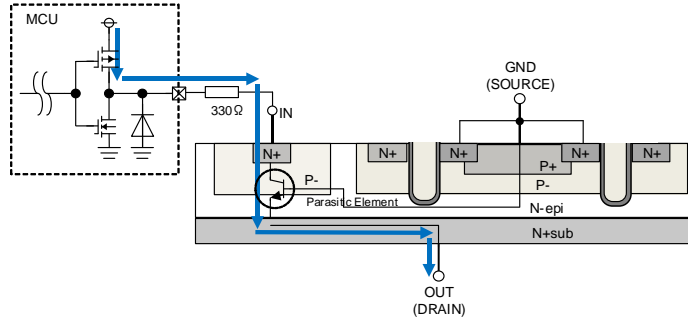

Figure 38. Negative current path (when power MOS is turned on)

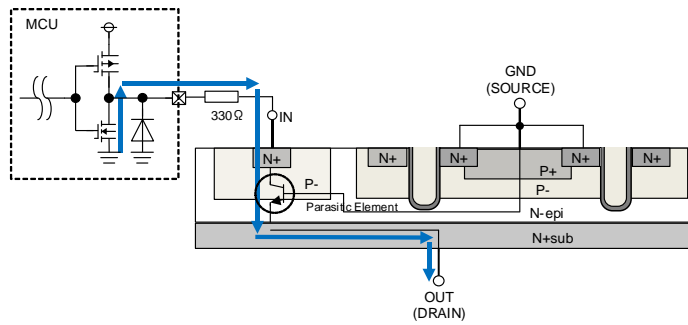
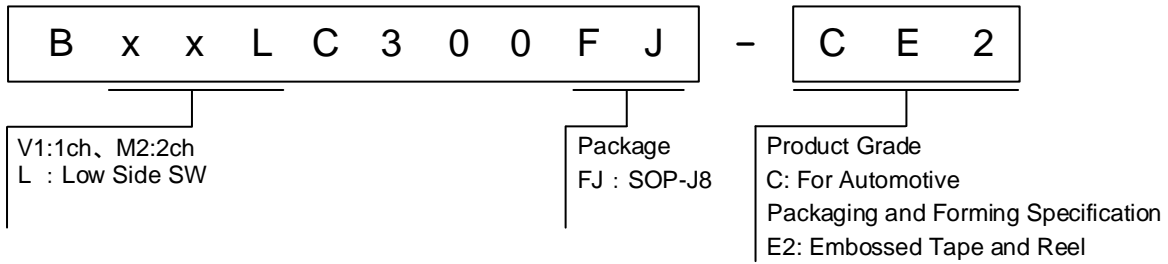

Figure 39. Negative current path (when power MOS is turned off)

Ordering Information



Marking Diagram

- BV1LC300FJ-C

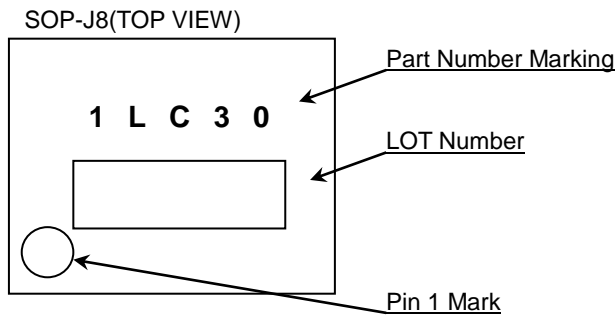

- BM2LC300FJ-C

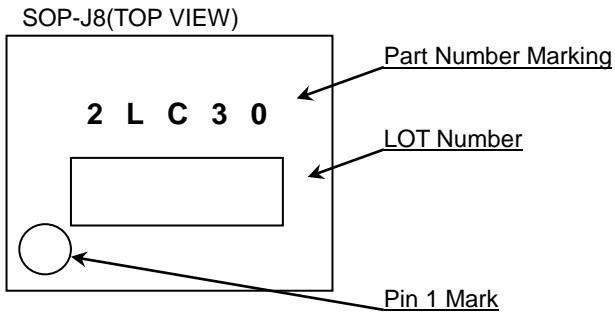

Physical Dimension and Packing Information

Package Name	SOP-J8
--------------	--------

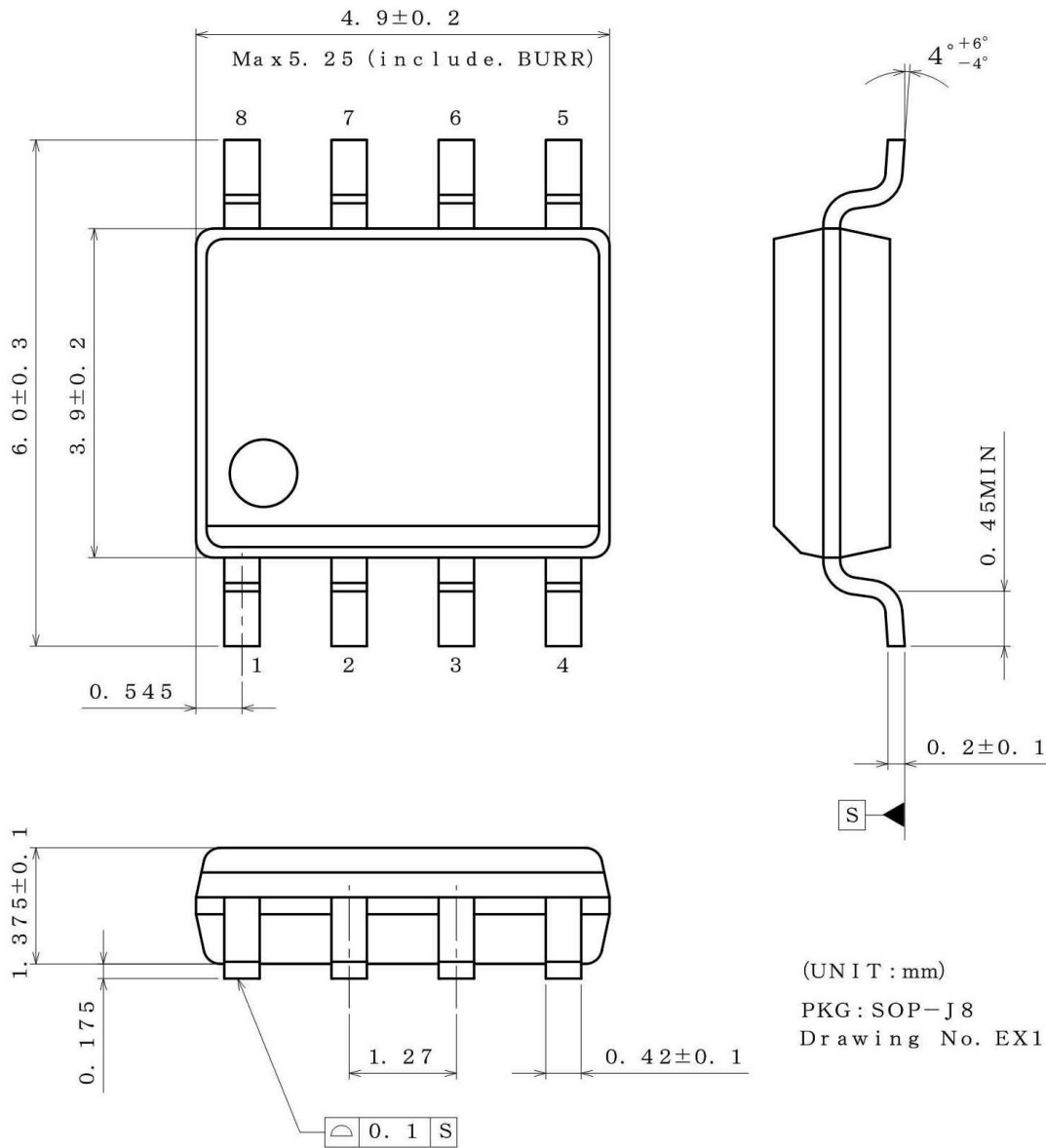

(UNIT : mm)
 PKG : SOP-J8
 Drawing No. EX111-5002

<Tape and Reel information>

Tape	Embossed carrier tape
Quantity	2500pcs
Direction of feed	E2 (The direction is the 1pin of product is at the upper left when you hold reel on the left hand and you pull out the tape on the right hand)

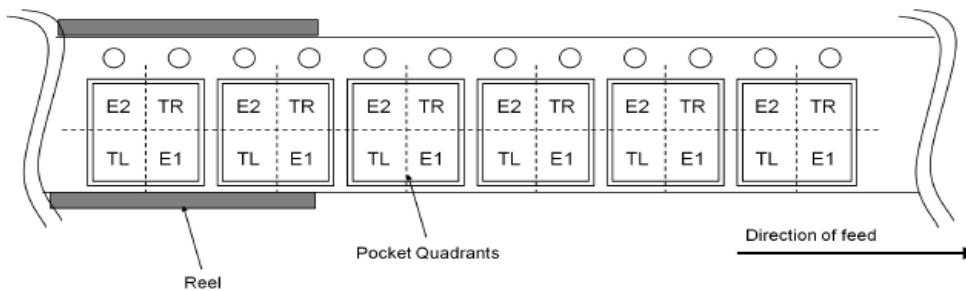

Revision History

Date	Revision	Changes
22.Mar.2018	001	New Release

Notice

Precaution on using ROHM Products

1. If you intend to use our Products in devices requiring extremely high reliability (such as medical equipment ^(Note 1), aircraft/spacecraft, nuclear power controllers, etc.) and whose malfunction or failure may cause loss of human life, bodily injury or serious damage to property ("Specific Applications"), please consult with the ROHM sales representative in advance. Unless otherwise agreed in writing by ROHM in advance, ROHM shall not be in any way responsible or liable for any damages, expenses or losses incurred by you or third parties arising from the use of any ROHM's Products for Specific Applications.

(Note1) Medical Equipment Classification of the Specific Applications

JAPAN	USA	EU	CHINA
CLASS III	CLASS III	CLASS II b	CLASS III
CLASS IV		CLASS III	

2. ROHM designs and manufactures its Products subject to strict quality control system. However, semiconductor products can fail or malfunction at a certain rate. Please be sure to implement, at your own responsibilities, adequate safety measures including but not limited to fail-safe design against the physical injury, damage to any property, which a failure or malfunction of our Products may cause. The following are examples of safety measures:
 - [a] Installation of protection circuits or other protective devices to improve system safety
 - [b] Installation of redundant circuits to reduce the impact of single or multiple circuit failure
3. Our Products are not designed under any special or extraordinary environments or conditions, as exemplified below. Accordingly, ROHM shall not be in any way responsible or liable for any damages, expenses or losses arising from the use of any ROHM's Products under any special or extraordinary environments or conditions. If you intend to use our Products under any special or extraordinary environments or conditions (as exemplified below), your independent verification and confirmation of product performance, reliability, etc. prior to use, must be necessary:
 - [a] Use of our Products in any types of liquid, including water, oils, chemicals, and organic solvents
 - [b] Use of our Products outdoors or in places where the Products are exposed to direct sunlight or dust
 - [c] Use of our Products in places where the Products are exposed to sea wind or corrosive gases, including Cl₂, H₂S, NH₃, SO₂, and NO₂
 - [d] Use of our Products in places where the Products are exposed to static electricity or electromagnetic waves
 - [e] Use of our Products in proximity to heat-producing components, plastic cords, or other flammable items
 - [f] Sealing or coating our Products with resin or other coating materials
 - [g] Use of our Products without cleaning residue of flux (even if you use no-clean type fluxes, cleaning residue of flux is recommended); or Washing our Products by using water or water-soluble cleaning agents for cleaning residue after soldering
 - [h] Use of the Products in places subject to dew condensation
4. The Products are not subject to radiation-proof design.
5. Please verify and confirm characteristics of the final or mounted products in using the Products.
6. In particular, if a transient load (a large amount of load applied in a short period of time, such as pulse. is applied, confirmation of performance characteristics after on-board mounting is strongly recommended. Avoid applying power exceeding normal rated power; exceeding the power rating under steady-state loading condition may negatively affect product performance and reliability.
7. De-rate Power Dissipation depending on ambient temperature. When used in sealed area, confirm that it is the use in the range that does not exceed the maximum junction temperature.
8. Confirm that operation temperature is within the specified range described in the product specification.
9. ROHM shall not be in any way responsible or liable for failure induced under deviant condition from what is defined in this document.

Precaution for Mounting / Circuit board design

1. When a highly active halogenous (chlorine, bromine, etc.) flux is used, the residue of flux may negatively affect product performance and reliability.
2. In principle, the reflow soldering method must be used on a surface-mount products, the flow soldering method must be used on a through hole mount products. If the flow soldering method is preferred on a surface-mount products, please consult with the ROHM representative in advance.

For details, please refer to ROHM Mounting specification

Precautions Regarding Application Examples and External Circuits

1. If change is made to the constant of an external circuit, please allow a sufficient margin considering variations of the characteristics of the Products and external components, including transient characteristics, as well as static characteristics.
2. You agree that application notes, reference designs, and associated data and information contained in this document are presented only as guidance for Products use. Therefore, in case you use such information, you are solely responsible for it and you must exercise your own independent verification and judgment in the use of such information contained in this document. ROHM shall not be in any way responsible or liable for any damages, expenses or losses incurred by you or third parties arising from the use of such information.

Precaution for Electrostatic

This Product is electrostatic sensitive product, which may be damaged due to electrostatic discharge. Please take proper caution in your manufacturing process and storage so that voltage exceeding the Products maximum rating will not be applied to Products. Please take special care under dry condition (e.g. Grounding of human body / equipment / solder iron, isolation from charged objects, setting of Ionizer, friction prevention and temperature / humidity control).

Precaution for Storage / Transportation

1. Product performance and soldered connections may deteriorate if the Products are stored in the places where:
 - [a] the Products are exposed to sea winds or corrosive gases, including Cl₂, H₂S, NH₃, SO₂, and NO₂
 - [b] the temperature or humidity exceeds those recommended by ROHM
 - [c] the Products are exposed to direct sunshine or condensation
 - [d] the Products are exposed to high Electrostatic
2. Even under ROHM recommended storage condition, solderability of products out of recommended storage time period may be degraded. It is strongly recommended to confirm solderability before using Products of which storage time is exceeding the recommended storage time period.
3. Store / transport cartons in the correct direction, which is indicated on a carton with a symbol. Otherwise bent leads may occur due to excessive stress applied when dropping of a carton.
4. Use Products within the specified time after opening a humidity barrier bag. Baking is required before using Products of which storage time is exceeding the recommended storage time period.

Precaution for Product Label

A two-dimensional barcode printed on ROHM Products label is for ROHM's internal use only.

Precaution for Disposition

When disposing Products please dispose them properly using an authorized industry waste company.

Precaution for Foreign Exchange and Foreign Trade act

Since concerned goods might be fallen under listed items of export control prescribed by Foreign exchange and Foreign trade act, please consult with ROHM in case of export.

Precaution Regarding Intellectual Property Rights

1. All information and data including but not limited to application example contained in this document is for reference only. ROHM does not warrant that foregoing information or data will not infringe any intellectual property rights or any other rights of any third party regarding such information or data.
2. ROHM shall not have any obligations where the claims, actions or demands arising from the combination of the Products with other articles such as components, circuits, systems or external equipment (including software).
3. No license, expressly or implied, is granted hereby under any intellectual property rights or other rights of ROHM or any third parties with respect to the Products or the information contained in this document. Provided, however, that ROHM will not assert its intellectual property rights or other rights against you or your customers to the extent necessary to manufacture or sell products containing the Products, subject to the terms and conditions herein.

Other Precaution

1. This document may not be reprinted or reproduced, in whole or in part, without prior written consent of ROHM.
2. The Products may not be disassembled, converted, modified, reproduced or otherwise changed without prior written consent of ROHM.
3. In no event shall you use in any way whatsoever the Products and the related technical information contained in the Products or this document for any military purposes, including but not limited to, the development of mass-destruction weapons.
4. The proper names of companies or products described in this document are trademarks or registered trademarks of ROHM, its affiliated companies or third parties.

General Precaution

1. Before you use our Products, you are requested to carefully read this document and fully understand its contents. ROHM shall not be in any way responsible or liable for failure, malfunction or accident arising from the use of any ROHM's Products against warning, caution or note contained in this document.
2. All information contained in this document is current as of the issuing date and subject to change without any prior notice. Before purchasing or using ROHM's Products, please confirm the latest information with a ROHM sales representative.
3. The information contained in this document is provided on an "as is" basis and ROHM does not warrant that all information contained in this document is accurate and/or error-free. ROHM shall not be in any way responsible or liable for any damages, expenses or losses incurred by you or third parties resulting from inaccuracy or errors of or concerning such information.