



# P-DUKE POWER

## MSD65 Single Series

AC-DC POWER SUPPLIES  
Up to 65 Watts

**5**  
YEARS  
WARRANTY

ROHS  
COMPLIANT

REACH  
COMPLIANT

+85°C  
-40°C  
AMBIENT TEMP.



Medical



Automation



Datacom



IPC



Industry



Measurement



Telecom



Automobile



Boat



Charger



PV



Railway

UL US CB CE UK CA



2 X MOPP	4000 VAC Reinforced Insulation	ADJ. Output Voltage	Internal EN55032 Class Filter <b>B</b>	LOW Leakage Current	LOW Standby Power	Operating Altitude <b>5000</b> meter	POWER GOOD Indicator	Protection Class I Class II	OCP	OVP	SCP
----------------	---	---------------------------	--	---------------------------	-------------------------	---	----------------------------	-----------------------------------	-----	-----	-----

### PART NUMBER STRUCTURE

M	S	D	65	U	S	12		-		
Application	Dimension Code	Output Power (W)	Input Voltage (VAC)	Output Quantity	Output Voltage (VDC)	Protection Type	Connector Options	Package Options		
Medical Application			U: Universal 85 ~ 264	S: Single	05:5 7P5:7.5 09:9 12:12 15:15 18:18 24:24 241:24 28:28 281:28 36:36 48:48 53:53	<input type="checkbox"/> :CLASS I <input type="checkbox"/> :CLASS II	<input type="checkbox"/> : JST <input type="checkbox"/> : Pin Type <input type="checkbox"/> : Molex <input type="checkbox"/> : Terminal Block	<input type="checkbox"/> : None <input type="checkbox"/> : Din rail type		

**TECHNICAL SPECIFICATION** All specifications are typical at 230VAC input, full load and 25°C unless otherwise noted

Model Number	Input Range	Output Voltage	Output Current Natural Convection	Max. Output Power	Input Power @No Load	Efficiency	Maximum Capacitor Load
	VAC	VDC	A	W	W	%	µF
MSD65US05-D MSD65US05-T	85 ~ 264	5	10	50	0.11	90	20000
MSD65US7P5-D MSD65US7P5-T	85 ~ 264	7.5	8.67	65	0.11	90	11560
MSD65US09-D MSD65US09-T	85 ~ 264	9	7.23	65	0.11	91	8033
MSD65US12-D MSD65US12-T	85 ~ 264	12	5.42	65	0.11	92.5	4520
MSD65US15-D MSD65US15-T	85 ~ 264	15	4.34	65	0.11	93.5	2900
MSD65US18-D MSD65US18-T	85 ~ 264	18	3.62	65	0.11	93	2015
MSD65US24-D MSD65US24-T	85 ~ 264	24	2.71	65	0.11	93.5	1130
MSD65US241-D MSD65US241-T	85 ~ 264	24	2.71	65	0.11	92	1130
MSD65US28-D MSD65US28-T	85 ~ 264	28	2.33	65	0.11	93.5	830
MSD65US281-D MSD65US281-T	85 ~ 264	28	2.33	65	0.11	91.5	830
MSD65US36-D MSD65US36-T	85 ~ 264	36	1.81	65	0.11	92.5	520
MSD65US48-D MSD65US48-T	85 ~ 264	48	1.36	65	0.11	93	285
MSD65US53-D MSD65US53-T	85 ~ 264	53	1.24	65	0.11	92.5	235

INPUT SPECIFICATIONS						
Parameter	Conditions		Min.	Typ.	Max.	Unit
Operating input voltage range	AC input		85		264	VAC
	DC input		120		370	VDC
Input frequency	AC input		47		63	Hz
Input current	100VAC and Full Load				1.6	A
	240VAC and Full Load				0.9	
No load input power	230VAC	Connector type		0.15		Watts
		Pin type		0.11		
Leakage current	264VAC			75		μA
Start up time					1000	ms
Rise time				20		ms
Hold up time	115VAC and Full Load			16		ms
Input inrush current	230VAC			60		A
Input protection	Internal fuse in line and neutral				T3.15A/250VAC	

OUTPUT SPECIFICATIONS						
Parameter	Conditions		Min.	Typ.	Max.	Unit
Output power					65	Watts
Initial set voltage accuracy	230VAC and Full Load		-1.0		+1.0	%
Line regulation	Low Line to High Line at Full Load		-0.2		+0.2	%
Load regulation	No Load to Full Load	5Vout	-0.7		+0.7	%
		Others	-0.5		+0.5	
	10% Load to 90% Load	5Vout	-0.6		+0.6	
		Others	-0.4		+0.4	
Voltage adjustability	Connector type	53Vout	-20		+10	%
		Others	-10		+10	
		Pin type	-10		+10	
Minimum load				0		%
Ripple and noise	Measured by 20MHz bandwidth					mVp-p
	With a 10μF/25V 1206 X7R MLCC	5Vout, 7.5Vout, 9Vout		75		
		12Vout, 15Vout, 18Vout		75		
	With a 1μF/50V 1206 X7R MLCC	24Vout, 28Vout, 36Vout		75		
48Vout, 53Vout			150			
Temperature coefficient			-0.02		+0.02	%/°C
Transient response	Load step from 50 ~ 75% change at 2.5A/μs	Peak deviation			3	% Vout
		Recovery time		600		μs
Over voltage protection	% of Vout(nom); Latch mode		125		140	%
Over load protection	% of Iout rated; Hiccup mode			145		%
Short circuit protection			Continuous, automatic recovery			

GENERAL SPECIFICATIONS						
Parameter	Conditions		Min.	Typ.	Max.	Unit
Isolation voltage	1 minute (2MOPP insulation)	Input to Output	4000			VAC
		Input (Output) to F.G.	2500			
Isolation resistance	500VDC		0.1			GΩ
Switching frequency	230VAC	5Vout		60		kHz
		7.5Vout		80		
		9Vout		70		
		Others		120		
Safety approvals	IEC/ EN/ ANSI/AAMI ES 60601-1					UL:E360199
	IEC/ EN/ UL 62368-1					UL:E193009
						CB:UL(Demko)
Weight		Connector type				295g (10.41oz)
		Pin type				265g (9.35oz)
MTBF	MIL-HDBK-217F, Full load					1.494 x 10 <sup>6</sup> hrs

## ENVIRONMENTAL SPECIFICATIONS

Parameter	Conditions	Min.	Typ.	Max.	Unit
Operating ambient temperature	Natural convection With derating	-40		+85	°C
Storage temperature range		-40		+85	°C
Operating altitude				5000	m
Shock					IEC60068-2-27
Vibration					IEC60068-2-6
Relative humidity	Non-condensing				5% to 95% RH

## EMC SPECIFICATIONS

Parameter	Conditions	Level
EMI	EN55011, EN55032, EN60601-1-2 and FCC Part 18 / 15	Conducted Class B Radiated Class B
Harmonic currents	EN61000-3-2 Full Load	Class A
Voltage flicker	EN61000-3-3	
EMS	EN55035 and EN60601-1-2	
ESD	EN61000-4-2	Perf. Criteria A
Radiated immunity	EN61000-4-3 20 V/m	Perf. Criteria A
Fast transient	EN61000-4-4 ± 2kV	Perf. Criteria A
Surge	EN61000-4-5 DM ± 1kV and CM ± 2kV	Perf. Criteria A
Conducted immunity	EN61000-4-6 20 Vr.m.s	Perf. Criteria A
Power frequency magnetic field	EN61000-4-8 30 A/m	Perf. Criteria A
Dip and interruptions	EN61000-4-11	

## CHARACTERISTIC CURVE

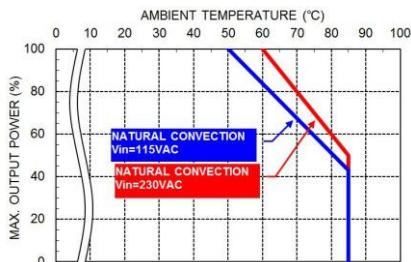

Derating Curve vs. Ambient Temperature  
Connector Option : (□): JST

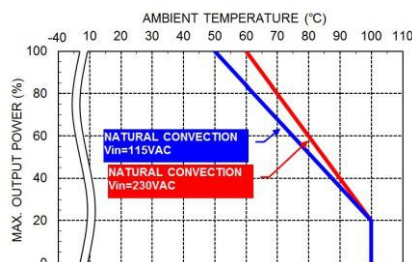

Derating Curve vs. Ambient Temperature  
Connector Option : (-M / -T / -D)

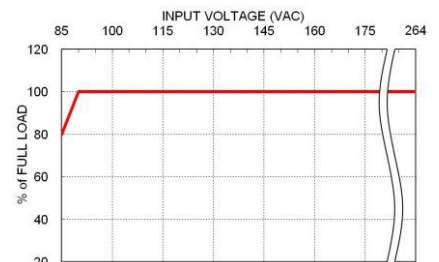

MSD65 Derating Curve vs. Input Voltage

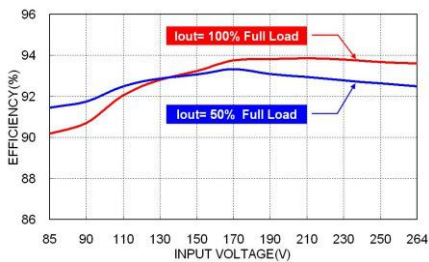

MSD65US24 Efficiency VS Input Voltage

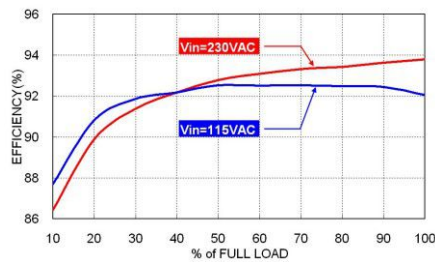

MSD65US24 Efficiency VS Output Load

## MECHANICAL DRAWING

MSD -D Pin Type

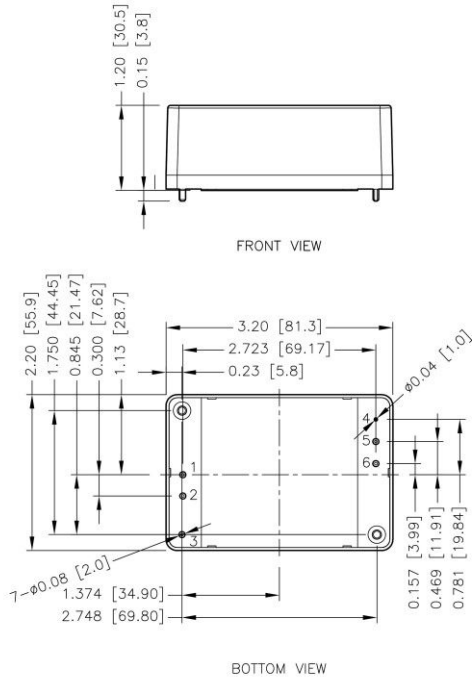

### PIN CONNECTION

#### FOR CLASS I : (MSD65USXX-D)

PIN	SINGLE	DIAMETER
1	Neutral	0.08 Inch
2	Line	0.08 Inch
3	PE	0.08 Inch
4	Trim	0.04 Inch
5	-Vout	0.08 Inch
6	+Vout	0.08 Inch

#### FOR CLASS II: (MSD65USXXB-D)

PIN	SINGLE	DIAMETER
1	Neutral	0.08 Inch
2	Line	0.08 Inch
3	No Pin	No Pin
4	Trim	0.04 Inch
5	-Vout	0.08 Inch
6	+Vout	0.08 Inch

- All dimensions in inch [mm]
- Tolerance :x.xx $\pm$ 0.02 [x.xx $\pm$ 0.5]  
x.xxx $\pm$ 0.010 [x.xx $\pm$ 0.25]

## RECOMMENDED PAD LAYOUT

MSD -D Pin type

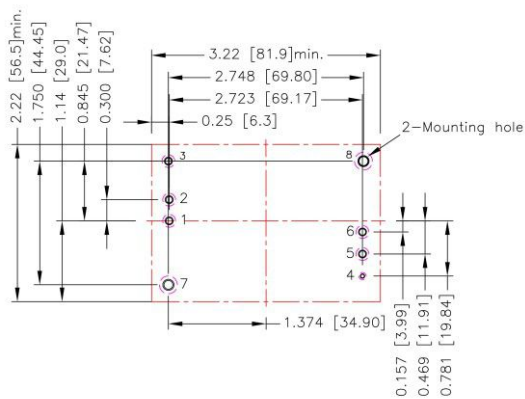

- All dimensions in inch[mm]  
Pad size(lead free recommended)  
Through hole 4: $\phi$ 0.051[1.30]  
Through hole 1.2.3.5.6: $\phi$ 0.091[2.30]  
Through hole of mounting: $\phi$ 0.126[3.20]  
Top view pad 4: $\phi$ 0.064[1.63]  
Top view pad 1.2.3.5.6: $\phi$ 0.113[2.88]  
Top view pad of mounting: $\phi$ 0.157[4.00]  
Bottom view pad 4: $\phi$ 0.102[2.60]  
Bottom view pad 1.2.3.5.6: $\phi$ 0.181[4.60]  
Bottom view pad of mounting: $\phi$ 0.252[6.40]
- The screw locked torque: MAX 3.5Kgf.cm/0.34N.m

## MECHANICAL DRAWING (CONTINUED)

MSD-**T** CLASS I

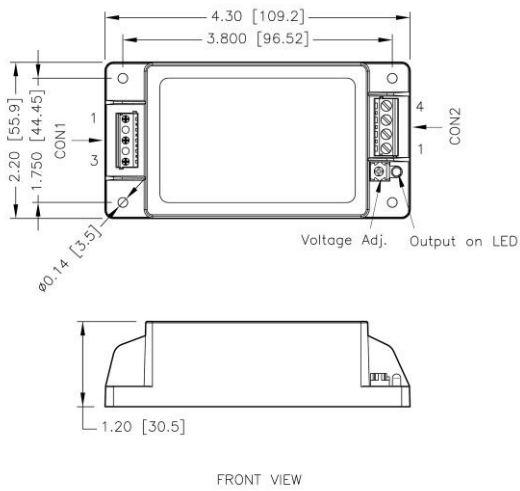

MSD-**T** CLASS II

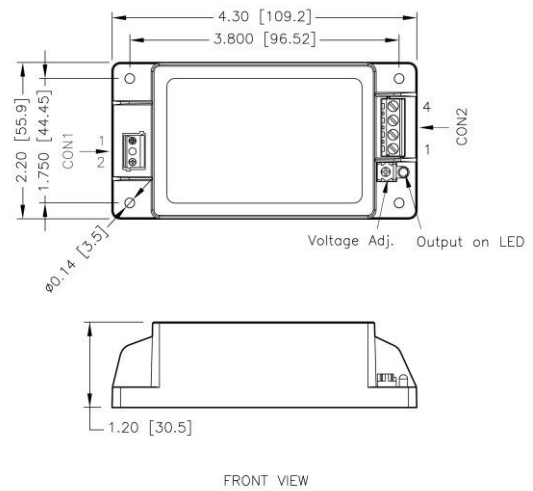

1. All dimensions in inch [mm]

Tolerance : x.xx±0.02 [x.x±0.5] x.xxx±0.010 [x.xx±0.25]

1. All dimensions in inch [mm]

Tolerance : x.xx±0.02 [x.x±0.5] x.xxx±0.010 [x.xx±0.25]

MSD-**TD1** CLASS I

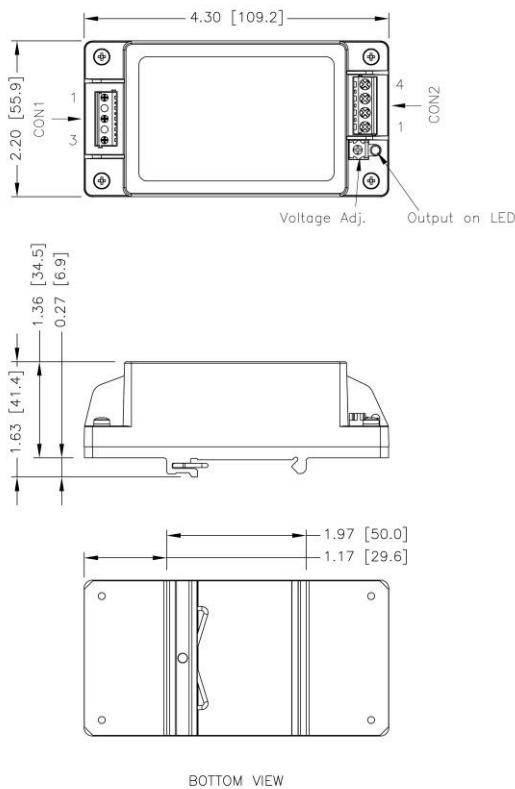

MSD-**TD1** CLASS II

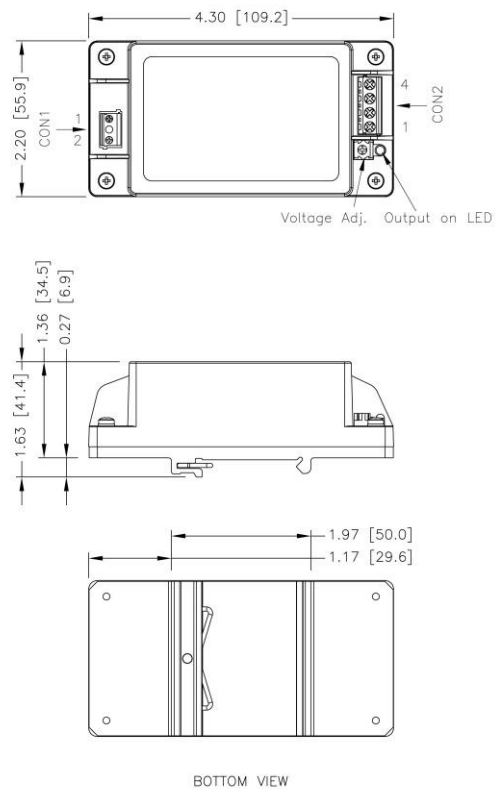

1. All dimensions in inch [mm]

Tolerance : x.xx±0.02 [x.x±0.5] x.xxx±0.010 [x.xx±0.25]

1. All dimensions in inch [mm]

Tolerance : x.xx±0.02 [x.x±0.5] x.xxx±0.010 [x.xx±0.25]

## CONNECTOR CONNECTIONS

### FOR CLASS I

CON1 – Input Connector	
Pin 1	PE
Pin 2	Line
Pin 3	Neutral

CON2 – Output Connector	
Pin 1,2	-Vout
Pin 3,4	+Vout

### FOR CLASS II

CON1 – Input Connector	
Pin 1	Line
Pin 2	Neutral

CON2 – Output Connector	
Pin 1,2	-Vout
Pin 3,4	+Vout

\*Either one of four screws holes of Chassis type can be considered as PE connection for CLASS I application.

## CONNECTOR OPTIONS

### FOR CLASS I

Blank	JST Type
	Mates with housing CON1: <b>VHR-5N</b> CON2: <b>VHR-4N</b>
	Crimp terminals CON1: <b>SVH-21T-P1.1</b> CON2: <b>SVH-21T-P1.1</b>

-M	Molex Type
	Mates with housing CON1: <b>09-50-8051</b> CON2: <b>09-50-8041</b>
	Crimp terminals CON1: <b>SD-2478</b> CON2: <b>SD-2478</b>

-T	Terminal Block
	Mates with <b>Screw locked torque</b> <b>MAX 2Kgf.cm/0.2N.m</b>
	<b>Wire dimension range</b> <b>26 ~ 16AWG</b>

### FOR CLASS II

Blank	JST Type
	Mates with housing CON1: <b>VHR-3N</b> CON2: <b>VHR-4N</b>
	Crimp terminals CON1: <b>SVH-21T-P1.1</b> CON2: <b>SVH-21T-P1.1</b>

-M	Molex Type
	Mates with housing CON1: <b>09-50-8031</b> CON2: <b>09-50-8041</b>
	Crimp terminals CON1: <b>SD-2478</b> CON2: <b>SD-2478</b>

-T	Terminal Block
	Mates with <b>Screw locked torque</b> <b>MAX 2Kgf.cm/0.2N.m</b>
	<b>Wire dimension range</b> <b>26 ~ 16AWG</b>

## OUTPUT VOLTAGE ADJUSTMENT

It allows the user to increase or decrease the output voltage of the module.

This is accomplished by connecting an external resistor between the Trim pin and either the +Vout or -Vout pins.

With an external resistor between the Trim and -Output pin, the output voltage increases.

With an external resistor between the Trim and +Output pin, the output voltage decreases.

The external Trim resistor needs to be at least 1/16W of rated power.

### Trim Up Equation

$$R_U = \left[ \frac{G \times L}{(V_{o,up} - L - K)} - H \right] \Omega$$

### Trim Down Equation

$$R_D = \left[ \frac{(V_{o,down} - L) \times G}{(V_o - V_{o,down})} - H \right] \Omega$$

### Trim Constants

Module	G	H	K	L
MSD65US05-D	5100	2000	0.8	2.5
MSD65US7P5-D	27000	2000	5	2.5
MSD65US09-D	30000	2000	6.5	2.5
MSD65US12-D	51000	2000	9.5	2.5
MSD65US15-D	51000	2000	12.5	2.5
MSD65US18-D	91000	2000	15.5	2.5
MSD65US24-D	120000	2000	21.5	2.5
MSD65US241-D	120000	2000	21.5	2.5
MSD65US28-D	150000	2000	25.5	2.5
MSD65US281-D	150000	2000	25.5	2.5
MSD65US36-D	270000	2000	33.5	2.5
MSD65US48-D	270000	2000	45.5	2.5
MSD65US53-D	300000	2000	50.5	2.5

### EXTERNAL OUTPUT TRIMMING

Output can be externally trimmed by using the method shown below.

Trim-up

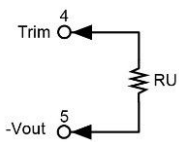

#### US05

$\Delta V$ (%)	1	2	3	4	5	6	7	8	9	10
Vout (V)	5.050	5.100	5.150	5.200	5.250	5.300	5.350	5.400	5.450	5.500
RU (k $\Omega$ )	373.000	185.500	123.000	91.750	73.000	60.500	51.571	44.875	39.667	35.500

#### US7P5

$\Delta V$ (%)	1	2	3	4	5	6	7	8	9	10
Vout (V)	7.575	7.650	7.725	7.800	7.875	7.950	8.025	8.100	8.175	8.250
RU (k $\Omega$ )	898.000	448.000	298.000	223.000	178.000	148.000	126.571	110.500	98.000	88.000

#### US09

$\Delta V$ (%)	1	2	3	4	5	6	7	8	9	10
Vout (V)	9.090	9.180	9.270	9.360	9.450	9.540	9.630	9.720	9.810	9.900
RU (k $\Omega$ )	831.333	414.667	275.778	206.333	164.667	136.889	117.048	102.167	90.593	81.333

#### US12

$\Delta V$ (%)	1	2	3	4	5	6	7	8	9	10
Vout (V)	12.120	12.240	12.360	12.480	12.600	12.720	12.840	12.960	13.080	13.200
RU (k $\Omega$ )	1060.500	529.250	352.167	263.625	210.500	175.083	149.786	130.813	116.056	104.250

#### US15

$\Delta V$ (%)	1	2	3	4	5	6	7	8	9	10
Vout (V)	15.150	15.300	15.450	15.600	15.750	15.900	16.050	16.200	16.350	16.500
RU (k $\Omega$ )	848.000	423.000	281.333	210.500	168.000	139.667	119.429	104.250	92.444	83.000

#### US18

$\Delta V$ (%)	1	2	3	4	5	6	7	8	9	10
Vout (V)	18.180	18.360	18.540	18.720	18.900	19.080	19.260	19.440	19.620	19.800
RU (k $\Omega$ )	1261.889	629.944	419.296	313.972	250.778	208.648	178.556	155.986	138.432	124.389



## OUTPUT VOLTAGE ADJUSTMENT(CONTINUED)

### Trim-up

US24										
$\Delta V$ (%)	1	2	3	4	5	6	7	8	9	10
Vout (V)	24.240	24.480	24.720	24.960	25.200	25.440	25.680	25.920	26.160	26.400
RU (k $\Omega$ )	1248.000	623.000	414.667	310.500	248.000	206.333	176.571	154.250	136.889	123.000

US241										
$\Delta V$ (%)	1	2	3	4	5	6	7	8	9	10
Vout (V)	24.240	24.480	24.720	24.960	25.200	25.440	25.680	25.920	26.160	26.400
RU (k $\Omega$ )	1248.000	623.000	414.667	310.500	248.000	206.333	176.571	154.250	136.889	123.000

US28										
$\Delta V$ (%)	1	2	3	4	5	6	7	8	9	10
Vout (V)	28.280	28.560	28.840	29.120	29.400	29.680	29.960	30.240	30.520	30.800
RU (k $\Omega$ )	1337.286	667.643	444.429	332.821	265.857	221.214	189.327	165.411	146.810	131.929

US281										
$\Delta V$ (%)	1	2	3	4	5	6	7	8	9	10
Vout (V)	28.280	28.560	28.840	29.120	29.400	29.680	29.960	30.240	30.520	30.800
RU (k $\Omega$ )	1337.286	667.643	444.429	332.821	265.857	221.214	189.327	165.411	146.810	131.929

US36										
$\Delta V$ (%)	1	2	3	4	5	6	7	8	9	10
Vout (V)	36.360	36.720	37.080	37.440	37.800	38.160	38.520	38.880	39.240	39.600
RU (k $\Omega$ )	1873.000	935.500	623.000	466.750	373.000	310.500	265.857	232.375	206.333	185.500

US48										
$\Delta V$ (%)	1	2	3	4	5	6	7	8	9	10
Vout (V)	48.480	48.960	49.440	49.920	50.400	50.880	51.360	51.840	52.320	52.800
RU (k $\Omega$ )	1404.250	701.125	466.750	349.563	279.250	232.375	198.893	173.781	154.250	138.625

US53										
$\Delta V$ (%)	1	2	3	4	5	6	7	8	9	10
Vout (V)	53.530	54.060	54.590	55.120	55.650	56.180	56.710	57.240	57.770	58.300
RU (k $\Omega$ )	1413.094	705.547	469.698	351.774	281.019	233.849	200.156	174.887	155.233	139.509

### Trim-down

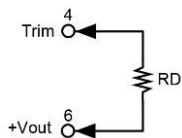

US05										
$\Delta V$ (%)	1	2	3	4	5	6	7	8	9	10
Vout (V)	4.950	4.900	4.850	4.800	4.750	4.700	4.650	4.600	4.550	4.500
RD (k $\Omega$ )	365.500	178.000	115.500	84.250	65.500	53.000	44.071	37.375	32.167	28.000

US7P5										
$\Delta V$ (%)	1	2	3	4	5	6	7	8	9	10
Vout (V)	7.425	7.350	7.275	7.200	7.125	7.050	6.975	6.900	6.825	6.750
RD (k $\Omega$ )	1771.000	871.000	571.000	421.000	331.000	271.000	228.143	196.000	171.000	151.000

US09										
$\Delta V$ (%)	1	2	3	4	5	6	7	8	9	10
Vout (V)	8.910	8.820	8.730	8.640	8.550	8.460	8.370	8.280	8.190	8.100
RD (k $\Omega$ )	2134.667	1051.333	690.222	509.667	401.333	329.111	277.524	238.833	208.741	184.667

US12										
$\Delta V$ (%)	1	2	3	4	5	6	7	8	9	10
Vout (V)	11.880	11.760	11.640	11.520	11.400	11.280	11.160	11.040	10.920	10.800
RD (k $\Omega$ )	3984.500	1965.750	1292.833	956.375	754.500	619.917	523.786	451.688	395.611	350.750

US15										
$\Delta V$ (%)	1	2	3	4	5	6	7	8	9	10
Vout (V)	14.850	14.700	14.550	14.400	14.250	14.100	13.950	13.800	13.650	13.500
RD (k $\Omega$ )	4197.000	2072.000	1363.667	1009.500	797.000	655.333	554.143	478.250	419.222	372.000

US18										
$\Delta V$ (%)	1	2	3	4	5	6	7	8	9	10
Vout (V)	17.820	17.640	17.460	17.280	17.100	16.920	16.740	16.560	16.380	16.200
RD (k $\Omega$ )	7743.111	3825.056	2519.037	1866.028	1474.222	1213.019	1026.444	886.514	777.679	690.611

**OUTPUT VOLTAGE ADJUSTMENT(CONTINUED)**

Trim-down

**US24**

$\Delta V$ (%)	1	2	3	4	5	6	7	8	9	10
Vout (V)	23.760	23.520	23.280	23.040	22.800	22.560	22.320	22.080	21.840	21.600
RD (k $\Omega$ )	10628.000	5253.000	3461.333	2565.500	2028.000	1669.667	1413.714	1221.750	1072.444	953.000

**US241**

$\Delta V$ (%)	1	2	3	4	5	6	7	8	9	10
Vout (V)	23.760	23.520	23.280	23.040	22.800	22.560	22.320	22.080	21.840	21.600
RD (k $\Omega$ )	10628.000	5253.000	3461.333	2565.500	2028.000	1669.667	1413.714	1221.750	1072.444	953.000

**US28**

$\Delta V$ (%)	1	2	3	4	5	6	7	8	9	10
Vout (V)	27.720	27.440	27.160	26.880	26.600	26.320	26.040	25.760	25.480	25.200
RD (k $\Omega$ )	13508.714	6678.357	4401.571	3263.179	2580.143	2124.786	1799.531	1555.589	1365.857	1214.071

**US281**

$\Delta V$ (%)	1	2	3	4	5	6	7	8	9	10
Vout (V)	27.720	27.440	27.160	26.880	26.600	26.320	26.040	25.760	25.480	25.200
RD (k $\Omega$ )	13508.714	6678.357	4401.571	3263.179	2580.143	2124.786	1799.531	1555.589	1365.857	1214.071

**US36**

$\Delta V$ (%)	1	2	3	4	5	6	7	8	9	10
Vout (V)	35.640	35.280	34.920	34.560	34.200	33.840	33.480	33.120	32.760	32.400
RD (k $\Omega$ )	24853.000	12290.500	8103.000	6009.250	4753.000	3915.500	3317.286	2868.625	2519.667	2240.500

**US48**

$\Delta V$ (%)	1	2	3	4	5	6	7	8	9	10
Vout (V)	47.520	47.040	46.560	46.080	45.600	45.120	44.640	44.160	43.680	43.200
RD (k $\Omega$ )	25321.750	12524.875	8259.250	6126.437	4846.750	3993.625	3384.250	2927.219	2571.750	2287.375

**US53**

$\Delta V$ (%)	1	2	3	4	5	6	7	8	9	10
Vout (V)	52.470	51.940	51.410	50.880	50.350	49.820	49.290	48.760	48.230	47.700
RD (k $\Omega$ )	28282.906	13990.453	9226.302	6844.226	5414.981	4462.151	3781.558	3271.113	2874.101	2556.491