



P-DUKE POWER

FKC15W Series

DC-DC Converter
Up to 15 Watts

3
YEARS
WARRANTY

ROHS
COMPLIANT

REACH
COMPLIANT



Automation



Datacom



IPC



Industry



Measurement



Telecom



Automobile



Boat



Charger



Medical



PV



Railway

UL US CB CE UK CA

1600
VDC
Isolation
Voltage

4 : 1
Wide
Input
Range

Internal
EN55032
Class
Filter **A**

LOW
Standby
Power

NO
Min. Load
Required

REMOTE
ON
OFF

OCP

SCP

UVP

PART NUMBER STRUCTURE

FKC15 -	48	S	05	W
Series Name	Input Voltage (VDC)	Output Quantity	Output Voltage (VDC)	Input Range
	24:9~36 48:18~75	S:Single	3P3:3.3 05:5.1 12:12 15:15	4 : 1
		D:Dual	05:±5 12:±12 15:±15	

TECHNICAL SPECIFICATION All specifications are typical at nominal input, full load and 25°C unless otherwise noted

Model Number	Input Range	Output Voltage	Output Current @ Full Load	Input Current @ No Load	Efficiency	Maximum Capacitor Load
	VDC	VDC	mA	mA	%	µF
FKC15-24S3P3W	9 ~ 36	3.3	4000	6	88	4700
FKC15-24S05W	9 ~ 36	5.1	3000	6	90	3300
FKC15-24S12W	9 ~ 36	12	1250	6	90	600
FKC15-24S15W	9 ~ 36	15	1000	6	90	400
FKC15-24D05W	9 ~ 36	±5	±1500	6	86	±1500
FKC15-24D12W	9 ~ 36	±12	±625	6	89	±288
FKC15-24D15W	9 ~ 36	±15	±500	6	90	±200
FKC15-48S3P3W	18 ~ 75	3.3	4000	4	89	4700
FKC15-48S05W	18 ~ 75	5.1	3000	4	89	3300
FKC15-48S12W	18 ~ 75	12	1250	4	90	600
FKC15-48S15W	18 ~ 75	15	1000	4	90	400
FKC15-48D05W	18 ~ 75	±5	±1500	4	86	±1500
FKC15-48D12W	18 ~ 75	±12	±625	4	89	±288
FKC15-48D15W	18 ~ 75	±15	±500	4	90	±200

INPUT SPECIFICATIONS

Parameter	Conditions	Min.	Typ.	Max.	Unit
Operating input voltage range	24Vin(nom) 48Vin(nom)	9 18	24 48	36 75	VDC
Start up voltage	24Vin(nom) 48Vin(nom)			9 18	VDC
Shutdown voltage	24Vin(nom) 48Vin(nom)	7 15	8 16	8.8 17.5	VDC
Start up time	Constant resistive load Power up Remote ON/OFF			60 60	ms
Input surge voltage	1 second, max. 24Vin(nom) 48Vin(nom)			50 100	VDC
Input filter				Pi type	
Remote ON/OFF	Referred to -Vin pin Positive logic DC-DC ON DC-DC OFF Input current of Ctrl pin Remote off input current	-0.5	2.5	Open or 3.0 ~ 12VDC Short or 0 ~ 1.2VDC +0.5	mA mA

OUTPUT SPECIFICATIONS

Parameter	Conditions	Min.	Typ.	Max.	Unit
Voltage accuracy		-1.0		+1.0	%
Line regulation	Low Line to High Line at Full Load	-0.2		+0.2	%
Load regulation	No Load to Full Load	Single		+0.5	%
		Dual		+1.0	
	10% Load to 90% Load	Single	-0.3		+0.3
		Dual	-0.8		+0.8
Cross regulation	Asymmetrical load 25%/100% FL	-5.0		+5.0	%
Ripple and noise	20MHz bandwidth With a 1µF/25V X7R MLCC		60		mVp-p
Temperature coefficient		-0.02		+0.02	%/°C
Transient response recovery time	25% load step change		250		µs
Over voltage protection		3.3Vout	3.9		VDC
		5.1Vout	6.2		
		12Vout	15		
		15Vout	18		
Over load protection	% of Iout rated; Hiccup mode		150		%
Short circuit protection					Continuous, automatic recovery

GENERAL SPECIFICATIONS

Parameter	Conditions	Min.	Typ.	Max.	Unit
Isolation voltage	1 minute Input to Output Input (Output) to Case	1600 1600			VDC
Isolation resistance	500VDC	1			GΩ
Isolation capacitance				2000	pF
Switching frequency		297	330	363	kHz
Safety approvals	IEC/ EN/ UL62368-1				UL:E193009 CB:UL(Demko)
Case material					Nickel-coated copper
Base material					FR4 PCB
Potting material					Silicone (UL94 V-0)
Weight					16.2g (0.57oz)
MTBF	MIL-HDBK-217F				1.603 x 10 ⁶ hrs

ENVIRONMENTAL SPECIFICATIONS

Parameter	Conditions	Min.	Typ.	Max.	Unit
Operating ambient temperature	With derating	-40		+105	°C
Maximum case temperature				105	°C
Storage temperature range		-55		+125	°C
Thermal impedance			20		°C/W
Thermal shock					MIL-STD-810F
Vibration					MIL-STD-810F
Relative humidity					5% to 95% RH

EMC SPECIFICATIONS

Parameter	Conditions	Level
EMI	EN55032 Without external components With external components	Class A Class B
EMS	EN55035	
ESD	EN61000-4-2 Air ± 8kV and Contact ± 6kV	Perf. Criteria A
Radiated immunity	EN61000-4-3 10 V/m	Perf. Criteria A
Fast transient	EN61000-4-4 ± 2kV	Perf. Criteria A
Surge	EN61000-4-5 ± 2kV With an external input filter capacitor (Nippon chemi-con KY series, 220μF/100V.)	Perf. Criteria A
Conducted immunity	EN61000-4-6 10 Vr.m.s	Perf. Criteria A
Power frequency magnetic field	EN61000-4-8 100A/m continuous; 1000A/m 1 second	Perf. Criteria A

CAUTION: This power module is not internally fused. An input line fuse must always be used.

CHARACTERISTIC CURVE

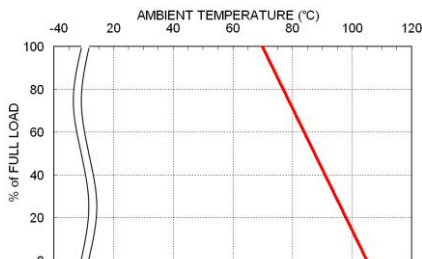

FKC15-48S05W Derating Curve

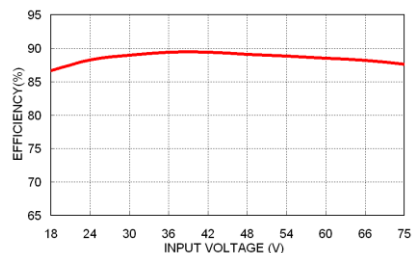

FKC15-48S05W Efficiency vs. Input Voltage

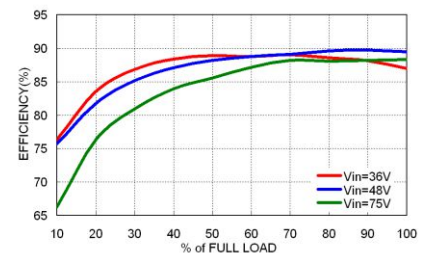

FKC15-48S05W Efficiency vs. Output Load

FUSE CONSIDERATION

This power module is not internally fused. An input line fuse must always be used.

This encapsulated power module can be used in a wide variety of applications, ranging from simple stand-alone operation to an integrated part of sophisticated power architecture.

To maximum flexibility, internal fusing is not included; however, to achieve maximum safety and system protection, always use an input line fuse.

The input line fuse suggest as below :

Model	Fuse Rating (A)	Fuse Type
FKC15-24S□□W、FKC15-24D□□W	3.15	Slow-Blow
FKC15-48S□□W、FKC15-48D□□W	1.6	Slow-Blow

The table based on the information provided in this data sheet on inrush energy and maximum DC input current at low Vin.

MECHANICAL DRAWING

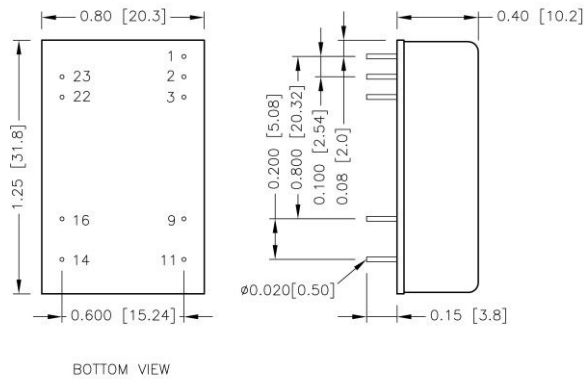

PIN CONNECTION

PIN	SINGLE	DUAL	PIN	SINGLE	DUAL
1	Ctrl	Ctrl			
2	-Vin	-Vin	23	+Vin	+Vin
3	-Vin	-Vin	22	+Vin	+Vin
9	NC	Common	16	-Vout	Common
11	NC	-Vout	14	+Vout	+Vout

- All dimensions in inch [mm]
- Tolerance :x.xx±0.02 [x.x±0.5]
x.xxx±0.01 [x.xx±0.25]
- Pin pitch tolerance ±0.01 [0.25]
- Pin dimension tolerance ±0.004[0.10]

RECOMMENDED PAD LAYOUT

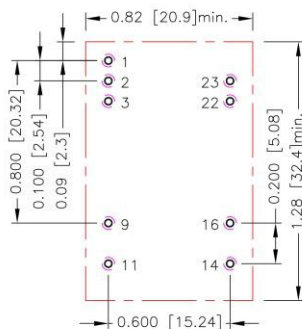

- All dimensions in inch[mm]
 Pad size(lead free recommended)
 Through hole 1.2.3.9.11.14.16.22.23: Φ0.031[0.80]
 Top view pad 1.2.3.9.11.14.16.22.23: Φ0.039[1.00]
 Bottom view pad 1.2.3.9.11.14.16.22.23: Φ0.063[1.60]

THERMAL CONSIDERATIONS

The power module operates in a variety of thermal environments.

However, sufficient cooling should be provided to help ensure reliable operation of the unit.

Heat is removed by conduction, convection, and radiation to the surrounding environment.

Proper cooling can be verified by measuring the point as the figure below.

The temperature at this location should not exceed "Maximum case temperature".

When operating, adequate cooling must be provided to maintain the test point temperature at or below "Maximum case temperature".

You can limit this temperature to a lower value for extremely high reliability.

- Thermal test condition with vertical direction by natural convection (20LFM).

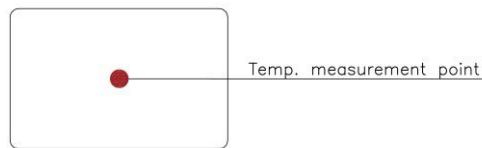

TOP VIEW