

NOTES.

1. 嵌合相手 : 501189****
MATE WITH : 501189****

2. ソルダーピン及びネイル平坦度は0.1MAX.
SOLDER PIN AND NAIL COPLANARITY TO BE 0.1MAX.

③ 極数/2 = 偶数に適用
APPLY FOR CKT SIZE/2=EVEN

④ トレードマーク : MXプラス1文字のアルファベットにて構成
TRADE MARK : FORMED BY MX AND 1 MORE LETTER OF ALPHABET.

キャビティー番号 : 1桁から2桁の数字にて構成
CAVITY No. : FORMED BY 1-2 DIGIT NUMBERS.

金型番号 : アルファベット1文字にて構成
MOLD No. : FORMED BY 1 LETTER OF ALPHABET.

番号 NO.	部品 PART	材質 MATERIAL
①	ウェハー WAFER	ポリアミド、UL94V-0、色 : 自然色 POLYAMIDE, UL94V-0, COLOR : NAURAL
②	ソルダーピン SOLDER PIN	りん青銅 PHOSPHOR BRONZE 金メッキ : 0.76 MICRO METER MINIMUM. GOLD PLATING ニッケルメッキ (下地) : 1.27 MICRO METER MINIMUM. NICKEL (UNDER PLATING)
③	ネイル NAIL	りん青銅 PHOSPHOR BRONZE 錫メッキ : 1.0 MICRO METER MINIMUM. TIN PLATING ニッケルメッキ (下地) : 1.0 MICRO METER MINIMUM. NICKEL (UNDER PLATING)
④	カバーテープ COVER TAPE	ポリイミドテープ POLYIMIDE TAPE

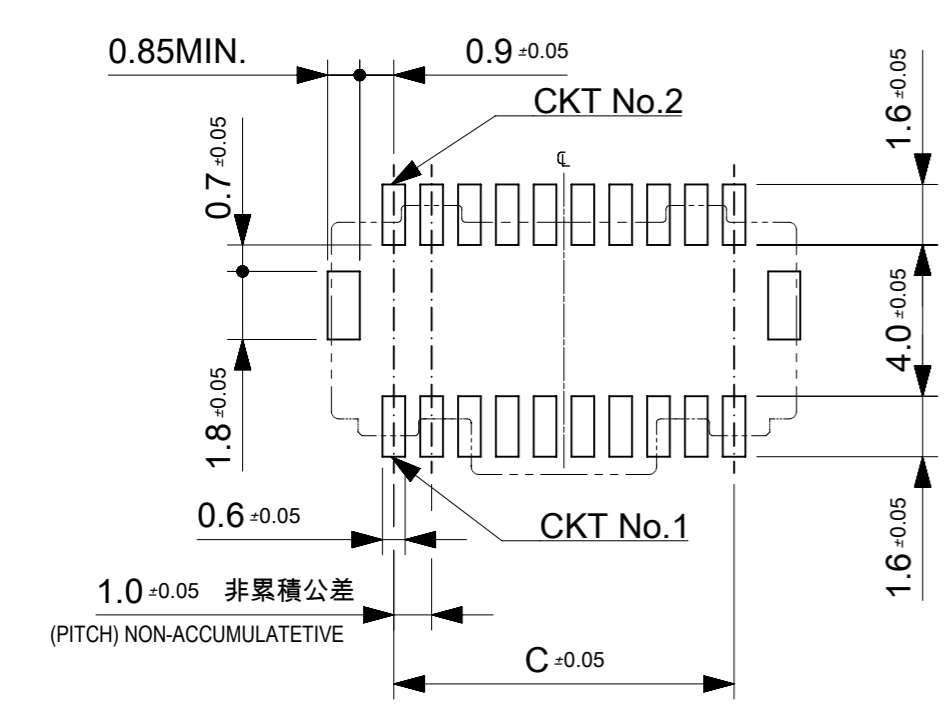
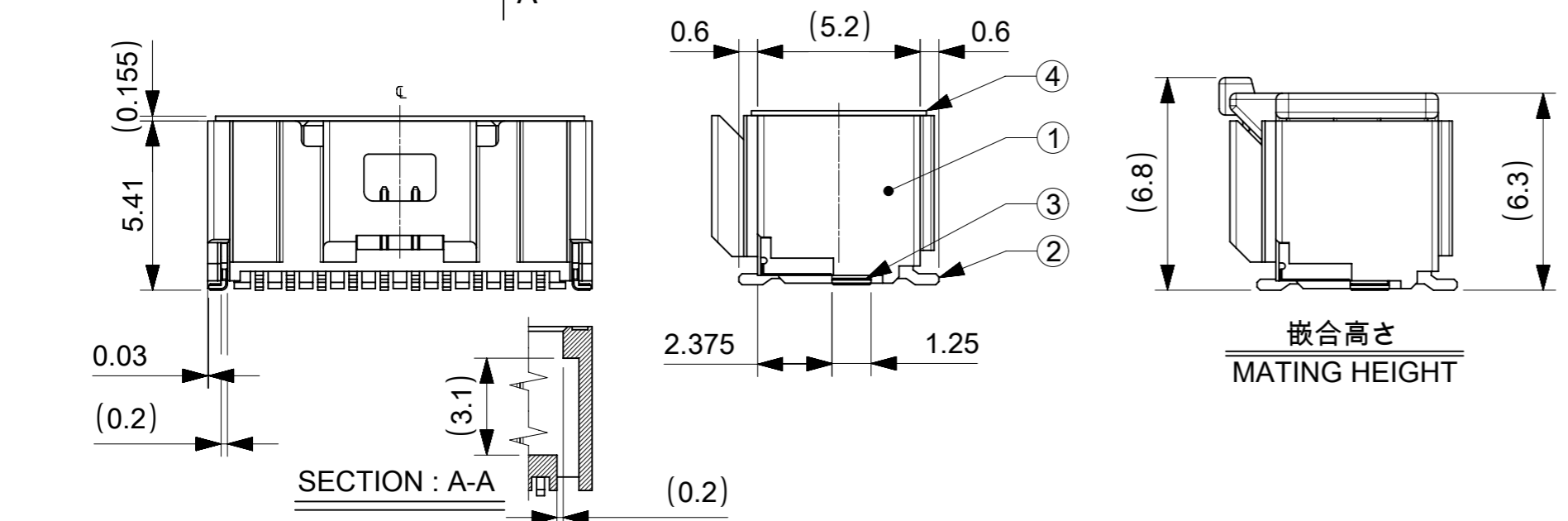

参考パターンレイアウト
RECOMMENDED PATTERN DIM.
(REF.)

無 NO	24	27.3	2035655027	50
	19	22.3	2035654027	40
	14	17.3	2035653027	30
	9	12.3	2035652027	20
有 YES	24	26.8 27.3	2035655017	50
	19	21.8 22.3	2035654017	40
	14	16.8 17.3	2035653017	30
	9	11.8 12.3	2035652017	20
カバーテープの有無 COVER TAPE	C B A	EMBOSSED PACKAGE オーダー番号: ORDER No.		CKT

CONNECTOR SERIES No.: 203565***9

THIS DRAWING CONTAINS INFORMATION THAT IS PROPRIETARY TO MOLEX ELECTRONIC TECHNOLOGIES, LLC AND SHOULD NOT BE USED WITHOUT WRITTEN PERMISSION

EC NO: 168346 DRWN: KYAMADA02 CHK'D: SAKIYAMA APPR: TKANEKO	2017/11/14	GENERAL TOLERANCES (UNLESS SPECIFIED)	DIMENSION UNITS	SCALE	molex		
	2017/11/30		mm	5:1			
	2017/12/01		DRWN BY	DATE		PICO-CLASP 1.0W/B DUAL-ROW ST WAFER ASSY 20-50CKT (GOLD VERSION 0.76)	
			KYAMADA02	2017/11/14			
		ANGULAR TOL ± 3.0 °	CHK'D BY	DATE	PRODUCT CUSTOMER DRAWING		
		4 PLACES ± 0.2	SAKIYAMA	2017/11/30			
		3 PLACES ± 0.2	APPR BY	DATE	SERIES	MATERIAL NUMBER	CUSTOMER
		2 PLACES ± 0.2	TKANEKO	2017/12/01	203565	SEE CHART	GENERAL
		1 PLACE ± 0.2	DRAWING SIZE	THIRD ANGLE PROJECTION	DOCUMENT NUMBER		
		0 PLACES ± 0.2	A3		2035652017-SD		
		DRAFT WHERE APPLICABLE MUST REMAIN WITHIN DIMENSIONS			DOC TYPE	DOC PART	SHEET NUMBER
					PSD	000	1 OF 3

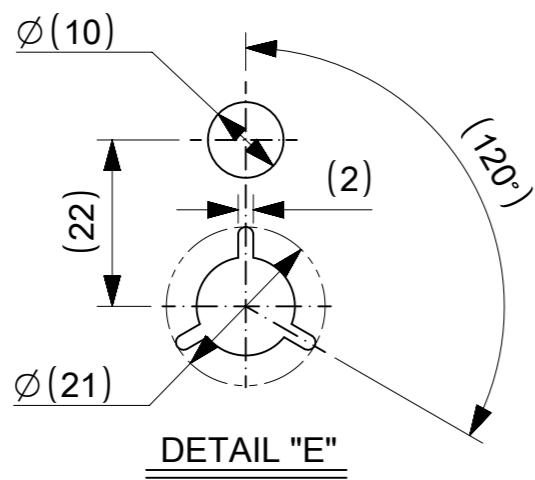
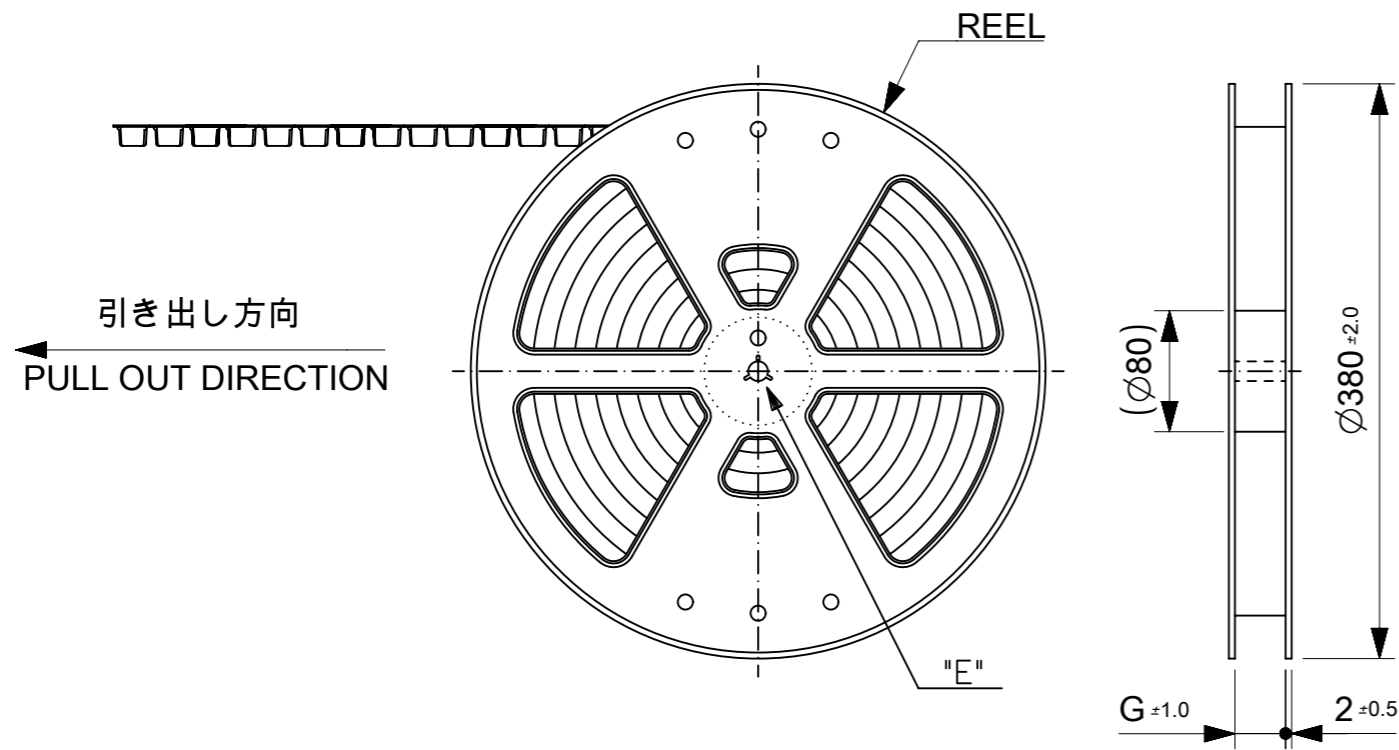

NOTES.

6.梱包数量：1,100個/リール
 NUMBER OF CONNECTORS : 1,100PIECES/REEL

7.リードテープ長さ
 LEAD TAPE LENGTH.

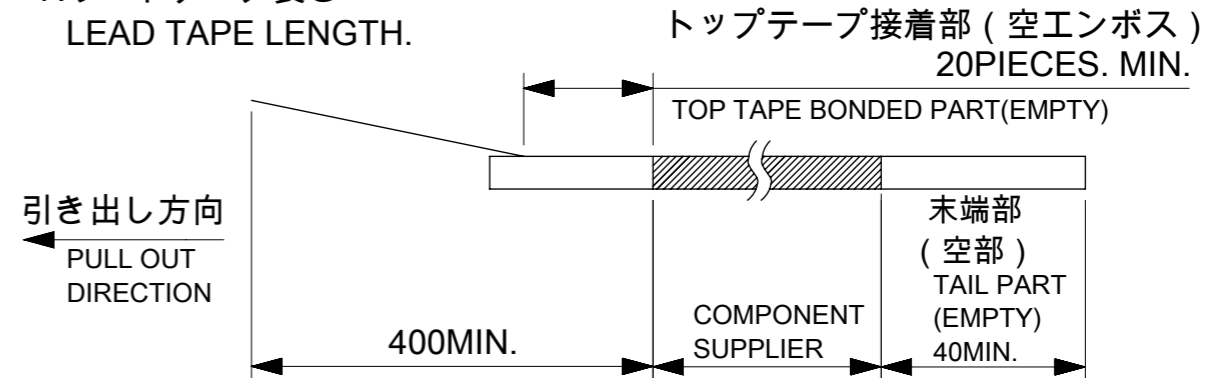

8.トップテープの剥離強度：0.1～1.3N (10.2～132.5gf)(剥離方向は下図参照)
 PEELING OFF FORCE OF TOP TAPE
 (PEELING DIRECTION AS SHOWN IN FOLLOWING FIGURE)
 尚、本規格値は、出荷時に適用。(但し、輸送時に剥離が発生しないこと)
 THIS REQUIREMENT SHOULD BE APPLIED AT SHIPMENT.
 PEEL OFF SHOULD NOT BE ALLOWED, DURING TRANSPORTION.

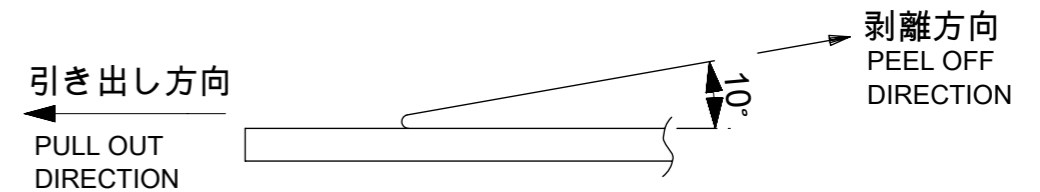

9.材料

MATERIAL

キャリアテープ：ポリプロピレン(PP)

CARRIER TAPE : POLYPROPYLENE

トップテープ：ポリエステル(PET),ポリエチレン(PE),ポリエチレン フラノエート(PEF),

TOP TAPE : POLYESTER, POLYETHYLENE, POLYETHYLENE FURANOATE

リール：ポリスチレン(PS),(リサイクル材を含む)

REEL : POLYSTYRENE (RECYCLE MATERIAL CONTAINED)

THIS DRAWING CONTAINS INFORMATION THAT IS PROPRIETARY TO MOLEX ELECTRONIC TECHNOLOGIES, LLC AND SHOULD NOT BE USED WITHOUT WRITTEN PERMISSION

EC NO: 168346 DRWN: KYAMADA02 CHK'D: SAKIYAMA APPR: TKANEKO	2017/11/14 2017/11/30 2017/12/01	GENERAL TOLERANCES (UNLESS SPECIFIED) ANGULAR TOL ± 3.0 ° 4 PLACES ± 0.2 3 PLACES ± 0.2 2 PLACES ± 0.2 1 PLACE ± 0.2 0 PLACES ± 0.2	DIMENSION UNITS: mm SCALE: 1:1 DRWN BY: KYAMADA02 DATE: 2017/11/14 CHK'D BY: SAKIYAMA DATE: 2017/11/30 APPR BY: TKANEKO DATE: 2017/12/01		
	DRAFT WHERE APPLICABLE MUST REMAIN WITHIN DIMENSIONS		DRAWING SIZE: A3 THIRD ANGLE PROJECTION		PICO-CLASP 1.0W/B DUAL-ROW ST WAFER ASSY 20-50CKT (GOLD VERSION 0.76)
			PRODUCT CUSTOMER DRAWING		SERIES: 203565 MATERIAL NUMBER: SEE CHART CUSTOMER: GENERAL
			DOCUMENT NUMBER: 2035652017-SD DOC TYPE: PSD DOC PART: 000 SHEET NUMBER: 2 OF 3		

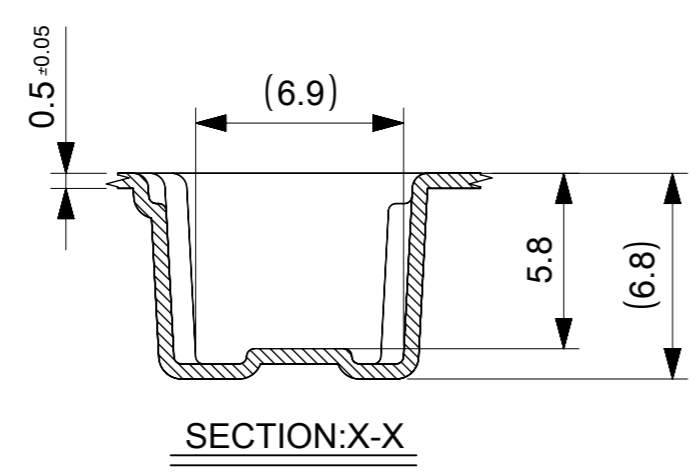
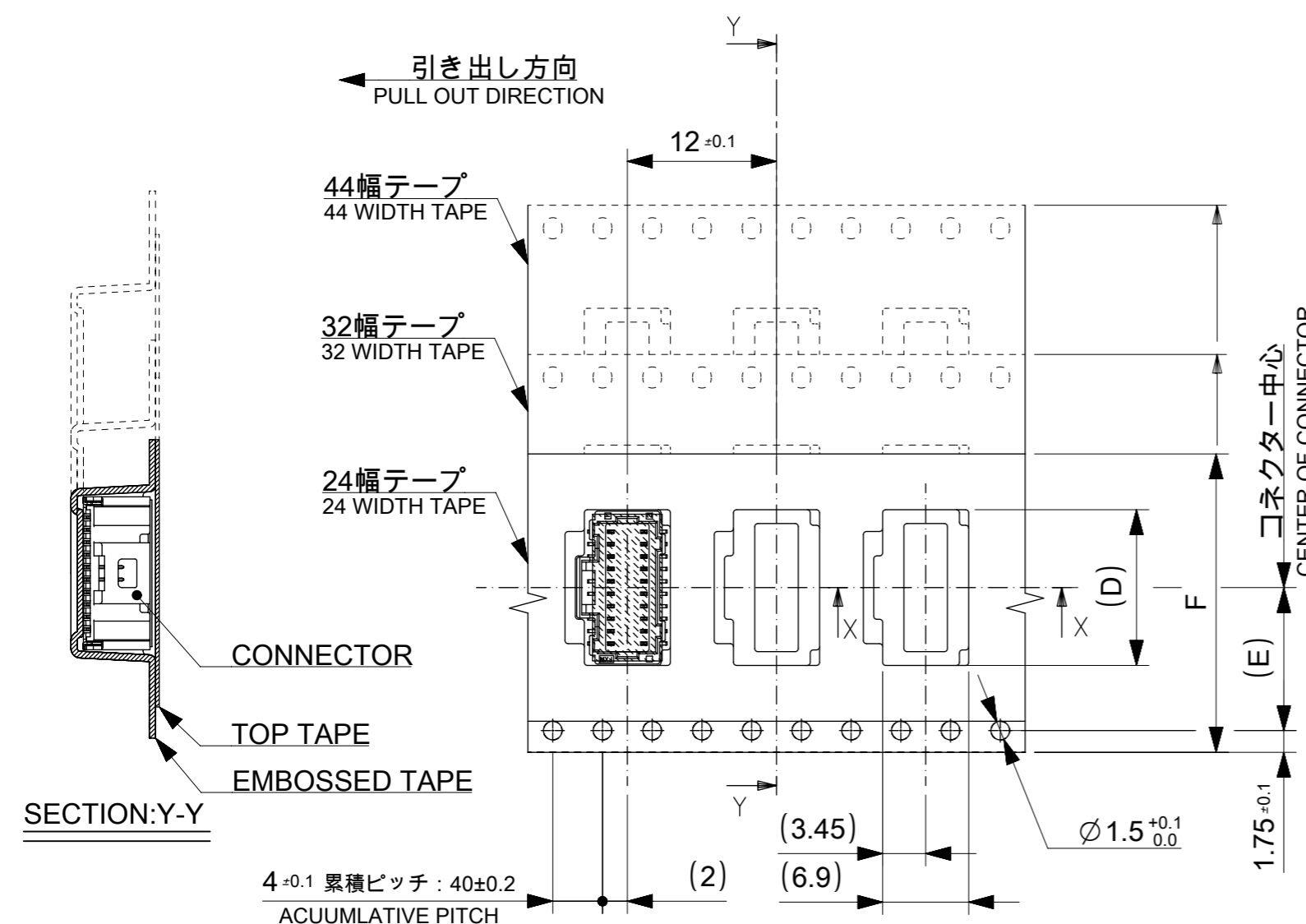

45.5	44 \pm 0.3	20.2	27.6	50
			22.6	40
33.5	32 \pm 0.3	14.2	17.6	30
25.5	24 \pm 0.3	11.5	12.6	20
G	F CARRIER TAPE WIDTH	(E)	(D)	CKT

THIS DRAWING CONTAINS INFORMATION THAT IS PROPRIETARY TO MOLEX ELECTRONIC TECHNOLOGIES, LLC AND SHOULD NOT BE USED WITHOUT WRITTEN PERMISSION

EC NO: 168346 DRWN: KYAMADA02 CHK'D: SAKIYAMA APPR: TKANEKO	2017/11/14	GENERAL TOLERANCES (UNLESS SPECIFIED)		DIMENSION UNITS	SCALE	
	2017/11/30	ANGULAR TOL \pm 3.0 °		mm	1:1	
	2017/12/01	4 PLACES	\pm 0.2	DRWN BY	DATE	
		3 PLACES	\pm 0.2	KYAMADA02	2017/11/14	
		2 PLACES	\pm 0.2	CHK'D BY	DATE	
	1 PLACE	\pm 0.2	SAKIYAMA	2017/11/30		
	0 PLACES	\pm 0.2	APPR BY	DATE		
			TKANEKO	2017/12/01		
DRAFT WHERE APPLICABLE MUST REMAIN WITHIN DIMENSIONS				DRAWING SIZE	THIRD ANGLE PROJECTION	
				A3		

PRODUCT CUSTOMER DRAWING		
SERIES	MATERIAL NUMBER	CUSTOMER
203565	SEE CHART	GENERAL
DOCUMENT NUMBER	DOC TYPE	DOC PART
2035652017-SD	PSD	000
SHEET NUMBER		
3 OF 3		