

- NOTE:
- MATERIAL :
HOUSING : GLASS FILLED LIQUID CRYSTAL POLYMER UL94-V0 BLACK
CONTACT: COPPER ALLOY
 - FINISH : SEE TABLE
 - PRODUCT SPECIFICATION : SEE TABLE
 - PACKAGING SPECIFICATION : PRODUCT SHALL BE PACKED IN TRAY, SEE TABLE
 - APPLICATION SPECIFICATION : 2072620193-AS
 - MATING CARD THICKNESS : 1.57 ±0.13
 - PCB THICKNESS : 1.57±0.15
 - MOLEX LOGO, DATECODE & PART NUMBER INDICATED ON HOUSING.
 - OPTION WITH M2 X 0.4 X 6.0 SCREW ATTACHED

THIS DRAWING CONTAINS INFORMATION THAT IS PROPRIETARY TO MOLEX ELECTRONIC TECHNOLOGIES, LLC AND SHOULD NOT BE USED WITHOUT WRITTEN PERMISSION		CURRENT REV DESC: REVISED		molex	
DIMENSION UNITS	SCALE				
mm	NTS			EDGELINE SLIVER 4C 1.57MM PCB 140CKT STRADDLE MOUNT	
GENERAL TOLERANCES (UNLESS SPECIFIED)				PRODUCT CUSTOMER DRAWING	
ANGULAR TOL ± 0.3°				DOCUMENT NUMBER	
4 PLACES ±		EC NO: 730748	2022/11/30	2086100002	
3 PLACES ±		DRWN: ASWINA	2022/12/06	PSD	000
2 PLACES ±	0.25	CHK'D: JAKEEMEW	2022/12/07	C2	
1 PLACE ±		APPR: SHLENI		REVISION	
0 PLACES ±		INITIAL REVISION:			
DRAFT WHERE APPLICABLE MUST REMAIN WITHIN DIMENSIONS		DRWN: SKANG	2018/11/16		
THIRD ANGLE PROJECTION		APPR: SHLENI	2019/06/16		
DRAWING		SERIES	MATERIAL NUMBER	CUSTOMER	
A3-SIZE		208610	SEE TABLE	GENERAL MARKET	
SHEET NUMBER		1 OF 4			

AIC MATING CARD

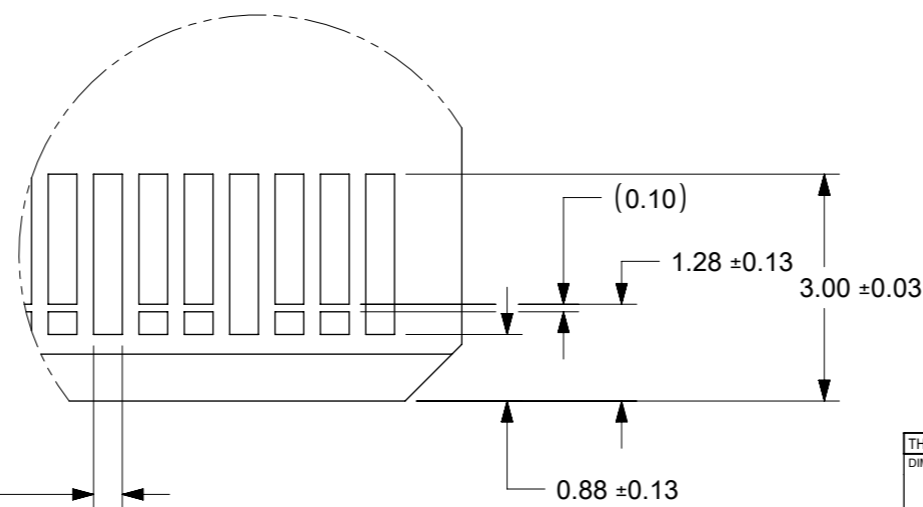
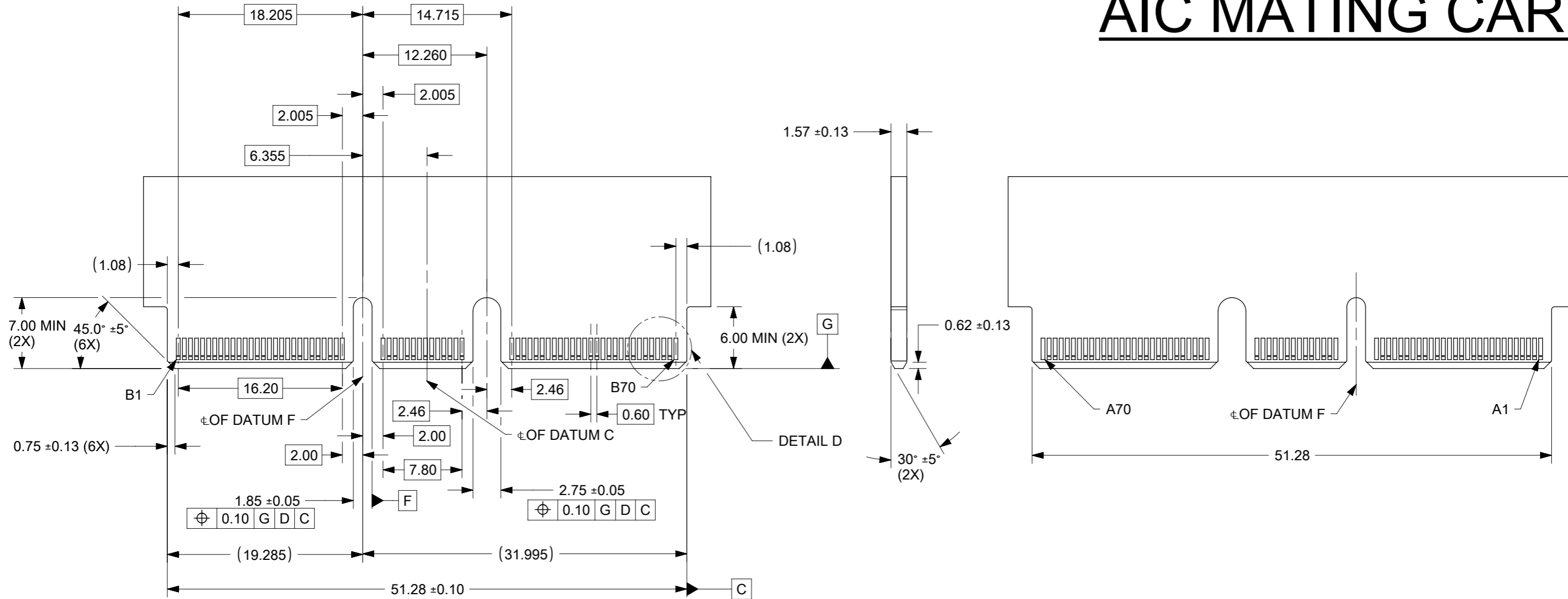

THIS DRAWING CONTAINS INFORMATION THAT IS PROPRIETARY TO MOLEX ELECTRONIC TECHNOLOGIES, LLC AND SHOULD NOT BE USED WITHOUT WRITTEN PERMISSION															
DIMENSION UNITS		SCALE		CURRENT REV DESC: REVISED											
mm		NTS													
GENERAL TOLERANCES (UNLESS SPECIFIED)															
ANGULAR TOL ± 0.3°				EC NO: 730748 DRWN: ASWINA 2022/11/30 CHK'D: JAKEEMEW 2022/12/06 APPR: SHLENI 2022/12/07											
4 PLACES ±															
3 PLACES ±				PRODUCT CUSTOMER DRAWING											
2 PLACES ± 0.25															
1 PLACE ±				INITIAL REVISION:		DOCUMENT NUMBER		DOC TYPE		DOC PART		REVISION			
0 PLACES ±				DRWN: SKANG 2018/11/16		2086100002		PSD		000		C2			
DRAFT WHERE APPLICABLE MUST REMAIN WITHIN DIMENSIONS				THIRD ANGLE PROJECTION		DRAWING		SERIES		MATERIAL NUMBER		CUSTOMER		SHEET NUMBER	
						A3-SIZE		208610		SEE TABLE		GENERAL MARKET		2 OF 4	

CONNECTOR FOOTPRINT

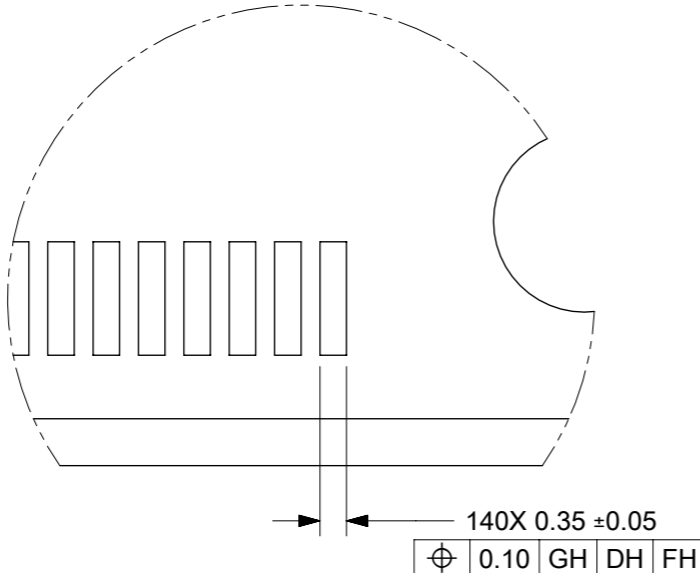
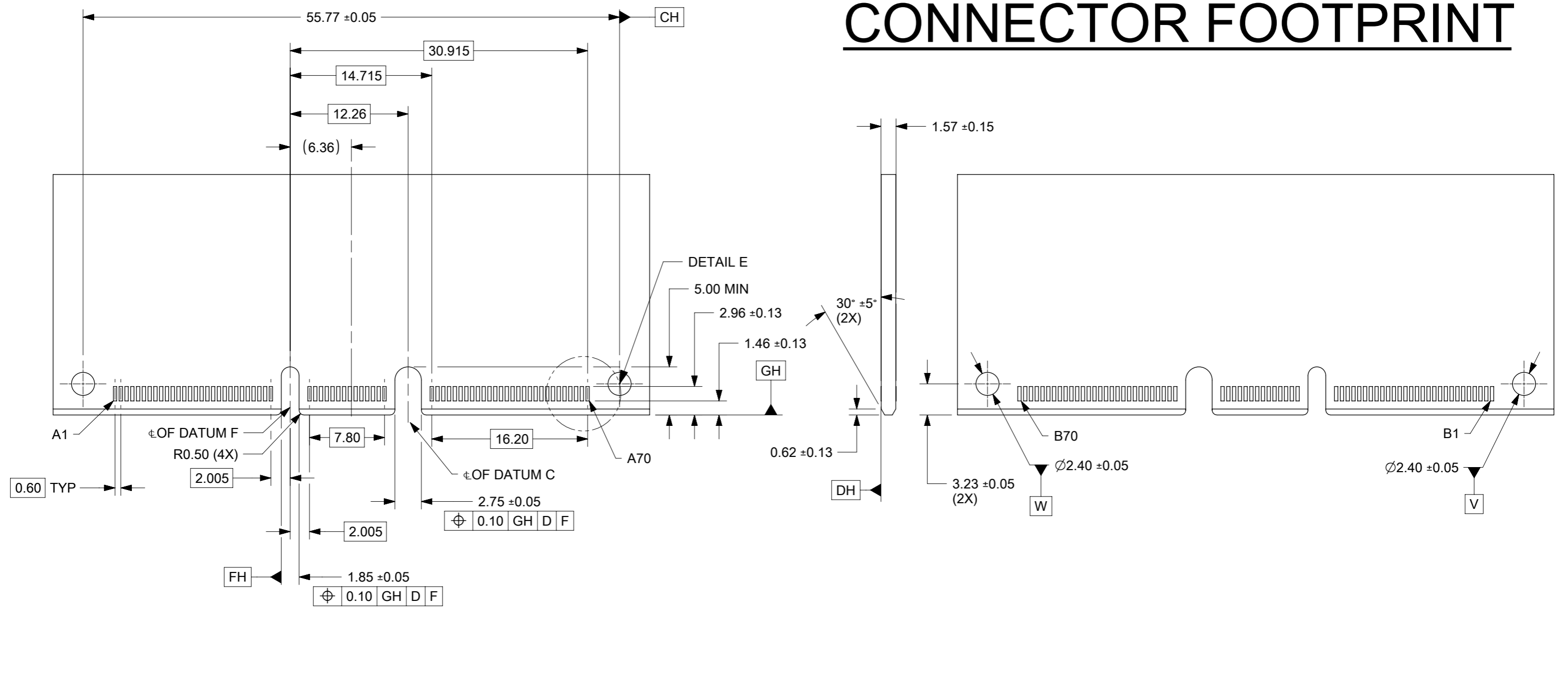

THIS DRAWING CONTAINS INFORMATION THAT IS PROPRIETARY TO MOLEX ELECTRONIC TECHNOLOGIES, LLC AND SHOULD NOT BE USED WITHOUT WRITTEN PERMISSION														
DIMENSION UNITS		SCALE		CURRENT REV DESC: REVISED						molex		EDGELINE SLIVER 4C 1.57MM PCB 140CKT STRADDLE MOUNT		
mm		NTS												
GENERAL TOLERANCES (UNLESS SPECIFIED)														
ANGULAR TOL ± 0.3°														
4 PLACES		±		EC NO: 730748				DOCUMENT NUMBER		DOC TYPE				
3 PLACES		±		DRWN: ASWINA 2022/11/30				2086100002		PSD				
2 PLACES		± 0.25		CHK'D: JAKEEMEW 2022/12/06				000		C2				
1 PLACE		±		APPR: SHLENI 2022/12/07				REVISION						
0 PLACES		±		INITIAL REVISION:										
				DRWN: SKANG 2018/11/16										
				APPR: SHLENI 2019/06/16										
DRAFT WHERE APPLICABLE MUST REMAIN WITHIN DIMENSIONS			THIRD ANGLE PROJECTION		DRAWING		SERIES		MATERIAL NUMBER		CUSTOMER		SHEET NUMBER	
			THIRD ANGLE PROJECTION		A3-SIZE		208610		SEE TABLE		GENERAL MARKET		3 OF 4	

F
E
D
C
B
A

ASSEMBLY PART NO.	CIRCUIT	PLATING OPTION	SCREW ATTACHED	PRODUCT SPECIFICATION	PACKAGING SPECIFICATION
2086100157	140	0.76µm/30µIn MIN. GOLD ON CONTACT 2.54µm/100µIn MIN. PURE MATTE TIN ON SOLDERTAILS OVER 1.27µm/50µIn MIN. NICKEL UNDERPLATE	NO	2086100157-PS	2072620140-PK
2086101140 			YES		2072621140-PK

THIS DRAWING CONTAINS INFORMATION THAT IS PROPRIETARY TO MOLEX ELECTRONIC TECHNOLOGIES, LLC AND SHOULD NOT BE USED WITHOUT WRITTEN PERMISSION

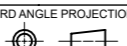
DIMENSION UNITS	SCALE	CURRENT REV DESC: REVISED		molex		
mm	NTS					
GENERAL TOLERANCES (UNLESS SPECIFIED)		EC NO: 730748		EDGELINE SLIVER 4C 1.57MM PCB 140CKT STRADDLE MOUNT		
ANGULAR TOL	± 0.3 °	DRWN: ASWINA 2022/11/30		PRODUCT CUSTOMER DRAWING		
4 PLACES	±	CHK'D: JAKEEMEW 2022/12/06		DOCUMENT NUMBER		
3 PLACES	±	APPR: SHLENI 2022/12/07		2086100002		
2 PLACES	± 0.25	INITIAL REVISION:		DOC TYPE	DOC PART	REVISION
1 PLACE	±	DRWN: SKANG 2018/11/16		PSD	000	C2
0 PLACES	±	APPR: SHLENI 2019/06/16		SHEET NUMBER		
DRAFT WHERE APPLICABLE MUST REMAIN WITHIN DIMENSIONS		THIRD ANGLE PROJECTION	DRAWING	SERIES	MATERIAL NUMBER	CUSTOMER
			A3-SIZE	208610	SEE TABLE	GENERAL MARKET
						4 OF 4