

**DESIGNED & DIMENSIONED  
IN MILLIMETERS [INCHES]**

**DO NOT  
SCALE FROM  
THIS PRINT**

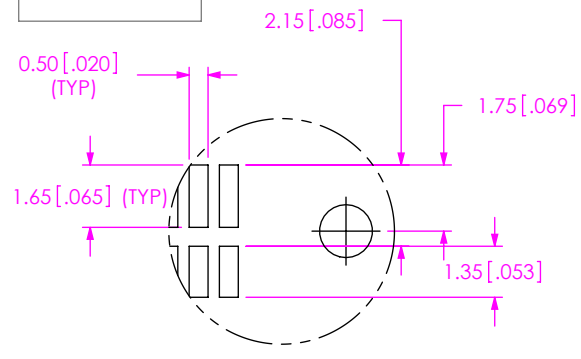

**DETAIL 'A'  
SCALE 5 : 1**

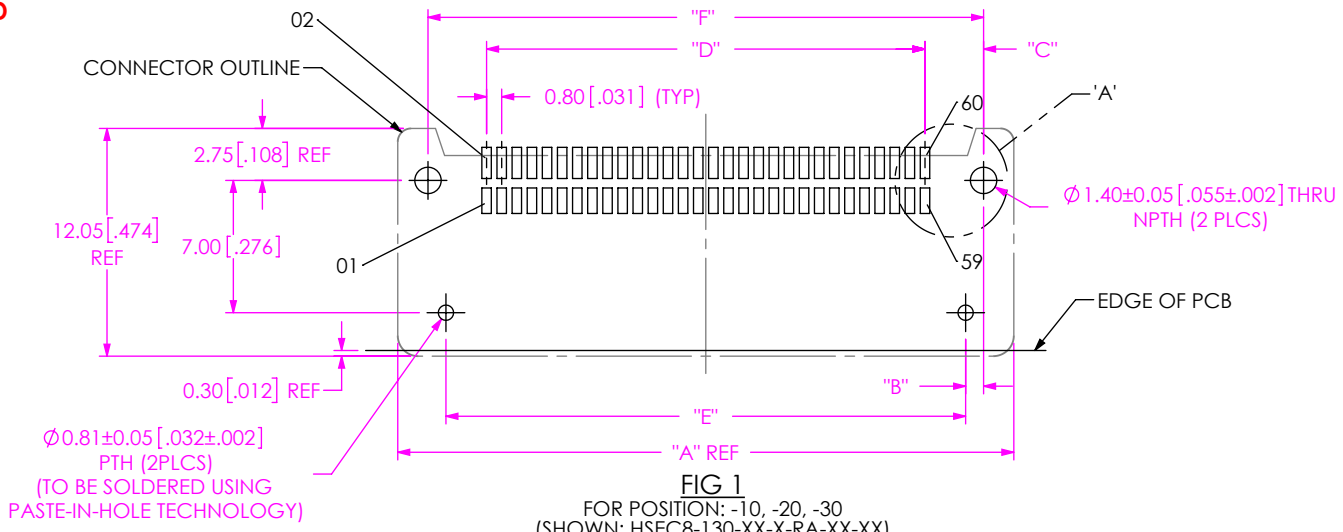

**FIG 1  
FOR POSITION: -10, -20, -30  
(SHOWN: HSEC8-130-XX-X-RA-XX-XX)**

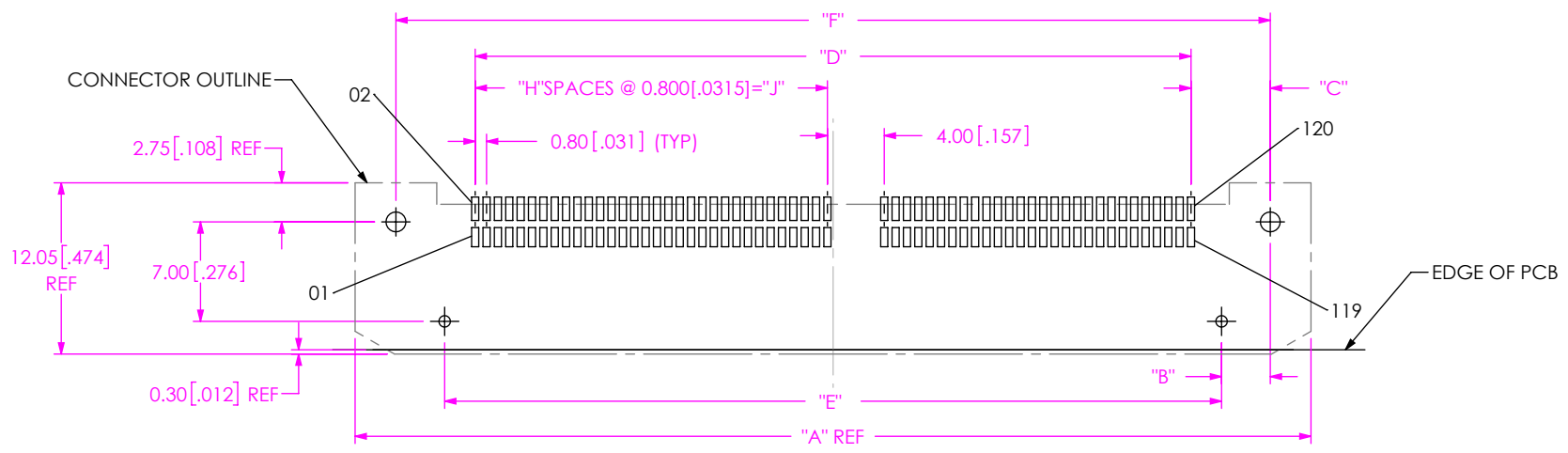

**FIG 2  
FOR POSITION: -09, -13, -25, -40, -49, -50, -60, -09-BL, -13-BL, -25-BL, -40-BL, -49-BL, -50-BL, -60-BL, -09-L2, -13-L2, -25-L2, -49-L2  
(SHOWN: HSEC8-160-XX-X-RA-XX-XX)  
(SAME AS FIG 1 EXCEPT AS SHOWN)**

**TABLE 1**

No OF POSITIONS	"A"	"B"	"C"	"D"	"E"	"F"	"H"	"J"
10	16.60 [0.654]	0.95 [0.037]	3.10 [0.122]	7.20 [0.283]	11.50 [0.453]	13.40 [0.528]	N/A	N/A
20	24.60 [0.969]	0.95 [0.037]	3.10 [0.122]	15.20 [0.598]	19.50 [0.768]	21.40 [0.843]	N/A	N/A
30	32.60 [1.283]	0.95 [0.037]	3.10 [0.122]	23.20 [0.913]	27.50 [1.083]	29.40 [1.157]	N/A	N/A
09	19.00 [0.748]	0.95 [0.037]	3.10 [0.122]	9.60 [0.378]	13.90 [0.547]	15.80 [0.622]	3	2.40 [0.094]
13	22.20 [0.874]	0.95 [0.037]	3.10 [0.122]	12.80 [0.504]	17.10 [0.673]	19.00 [0.748]	5	4.00 [0.157]
25	31.80 [1.252]	0.95 [0.037]	3.10 [0.122]	22.40 [0.882]	26.70 [1.051]	28.60 [1.126]	5	4.00 [0.157]
40	43.80 [1.724]	0.95 [0.037]	3.10 [0.122]	34.40 [1.354]	38.70 [1.524]	40.60 [1.598]	21	16.80 [0.661]
49	51.00 [2.008]	0.95 [0.037]	3.10 [0.122]	41.60 [1.638]	45.90 [1.807]	47.80 [1.882]	26	20.80 [0.819]
50	51.80 [2.039]	0.95 [0.037]	3.10 [0.122]	42.40 [1.669]	46.70 [1.839]	48.60 [1.913]	26	20.80 [0.819]
60	59.80 [2.354]	0.95 [0.037]	3.10 [0.122]	50.40 [1.984]	54.70 [2.154]	56.60 [2.228]	31	24.80 [0.976]
09-BL	42.38 [1.669]	3.43 [0.135]	5.58 [0.220]	9.60 [0.378]	13.90 [0.547]	20.75 [0.817]	3	2.40 [0.094]
13-BL	45.58 [1.794]	3.43 [0.135]	5.58 [0.220]	12.80 [0.504]	17.10 [0.673]	23.95 [0.943]	5	4.00 [0.157]
25-BL	55.18 [2.172]	3.43 [0.135]	5.58 [0.220]	22.40 [0.882]	26.70 [1.051]	33.55 [1.321]	5	4.00 [0.157]
40-BL	67.18 [2.645]	3.43 [0.135]	5.58 [0.220]	34.40 [1.354]	38.70 [1.524]	45.55 [1.793]	21	16.80 [0.661]
49-BL	74.38 [2.928]	3.43 [0.135]	5.58 [0.220]	41.60 [1.638]	45.90 [1.807]	52.75 [2.077]	26	20.80 [0.819]
50-BL	75.18 [2.960]	3.43 [0.135]	5.58 [0.220]	42.40 [1.669]	46.70 [1.839]	53.55 [2.108]	26	20.80 [0.819]
60-BL	83.18 [3.275]	3.43 [0.135]	5.58 [0.220]	50.40 [1.984]	54.70 [2.154]	61.55 [2.423]	31	24.80 [0.976]
09-L2	20.86 [0.821]	0.02 [0.001]	3.10 [0.122]	9.60 [0.378]	15.76 [0.620]	15.80 [0.622]	3	2.40 [0.094]
13-L2	24.06 [0.947]	0.02 [0.001]	3.10 [0.122]	12.80 [0.504]	18.96 [0.746]	19.00 [0.748]	5	4.00 [0.157]
25-L2	33.66 [1.325]	0.02 [0.001]	3.10 [0.122]	22.40 [0.882]	28.56 [1.124]	28.60 [1.126]	5	4.00 [0.157]
49-L2	52.86 [2.081]	0.02 [0.001]	3.10 [0.122]	41.60 [1.638]	47.76 [1.880]	47.80 [1.882]	26	20.80 [0.819]

F:\dwg\misc\mktg\footprnt\HSEC8-1XX-XX-X-RA-XX-XX-FOOTPRINT.sldrw

UNLESS OTHERWISE SPECIFIED,  
DIMENSIONS ARE IN MILLIMETERS.  
TOLERANCES ARE:  
DECIMALS      ANGLES  
X.X: ±0.3[.01]      5°  
X.XX: ±0.10[.004]  
X.XXX: ±0.051[.0020]

**PROPRIETARY NOTE**  
THIS DOCUMENT CONTAINS CONFIDENTIAL AND PROPRIETARY INFORMATION AND ALL DESIGN, MANUFACTURING, REPRODUCTION, USE, PATENT RIGHTS AND SALES RIGHTS ARE EXPRESSLY RESERVED BY SAMTEC, INC. THIS DOCUMENT SHALL NOT BE DISCLOSED, IN WHOLE OR PART, TO ANY UNAUTHORIZED PERSON OR ENTITY NOR REPRODUCED, TRANSFERRED OR INCORPORATED IN ANY OTHER PROJECT IN ANY MANNER WITHOUT THE EXPRESS WRITTEN CONSENT OF SAMTEC, INC.



520 PARK EAST BLVD, NEW ALBANY, IN 47150  
PHONE: 812-944-6733      FAX: 812-948-5047  
e-Mail info@SAMTEC.com      code 55322

NOTE:  
STENCIL TO BE 0.15 [.006] THICK.

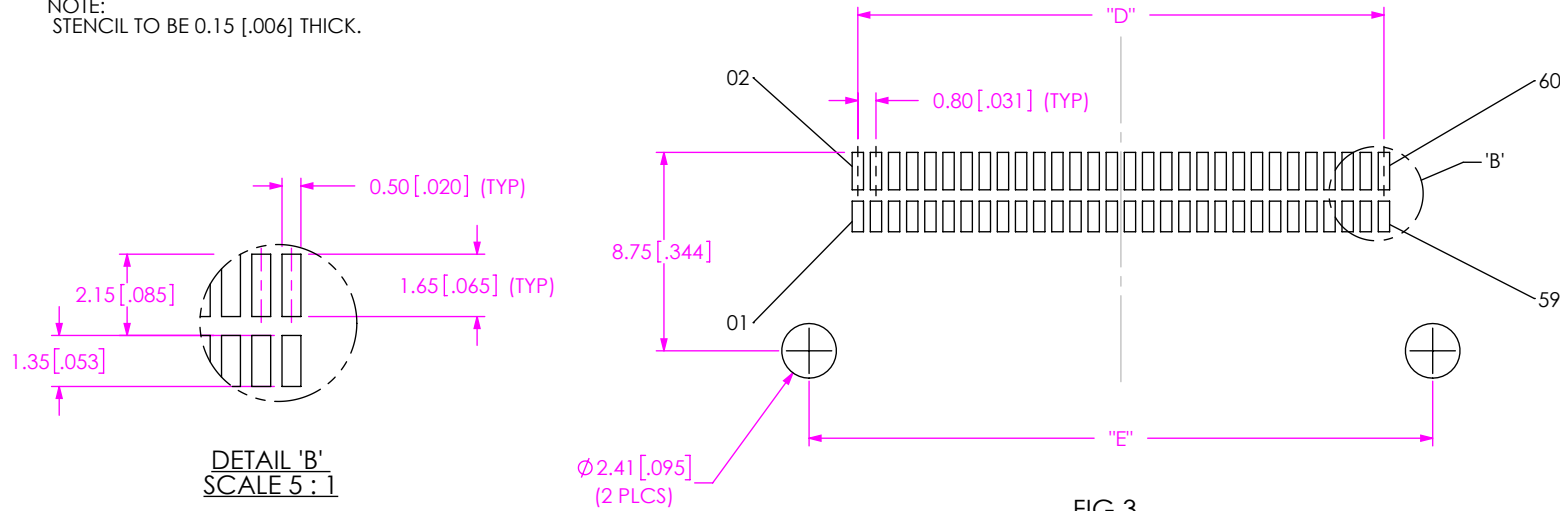

FIG 3  
FOR POSITION: -10, -20, -30  
(SHOWN: HSEC8-130-XX-X-RA-XX-XX)

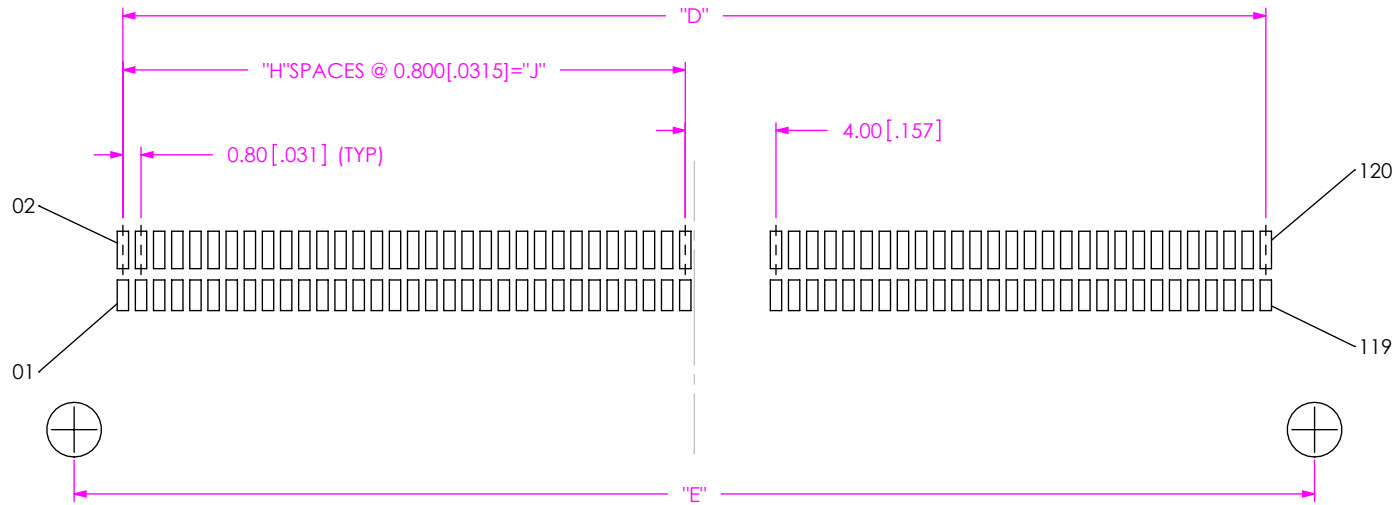

FIG 4  
FOR POSITION: -09, -13, -25, -40, -49, -50, -60, -09-BL, -13-BL, -25-BL, -40-BL, -49-BL, -50-BL,  
-60-BL, -09-L2, -13-L2, -25-L2, -49-L2  
(SHOWN: HSEC8-160-XX-X-RA-XX-XX)  
(SAME AS FIG 3 EXCEPT AS SHOWN)

PROPRIETARY NOTE  
THIS DOCUMENT CONTAINS CONFIDENTIAL AND PROPRIETARY INFORMATION AND ALL DESIGN, MANUFACTURING, REPRODUCTION, USE, PATENT RIGHTS AND SALES RIGHTS ARE EXPRESSLY RESERVED BY SAMTEC, INC. THIS DOCUMENT SHALL NOT BE DISCLOSED, IN WHOLE OR PART, TO ANY UNAUTHORIZED PERSON OR ENTITY NOR REPRODUCED, TRANSFERRED OR INCORPORATED IN ANY OTHER PROJECT IN ANY MANNER WITHOUT THE EXPRESS WRITTEN CONSENT OF SAMTEC, INC.



520 PARK EAST BLVD, NEW ALBANY, IN 47150  
PHONE: 812-944-6733 FAX: 812-948-5047  
e-Mail info@SAMTEC.com code 55322

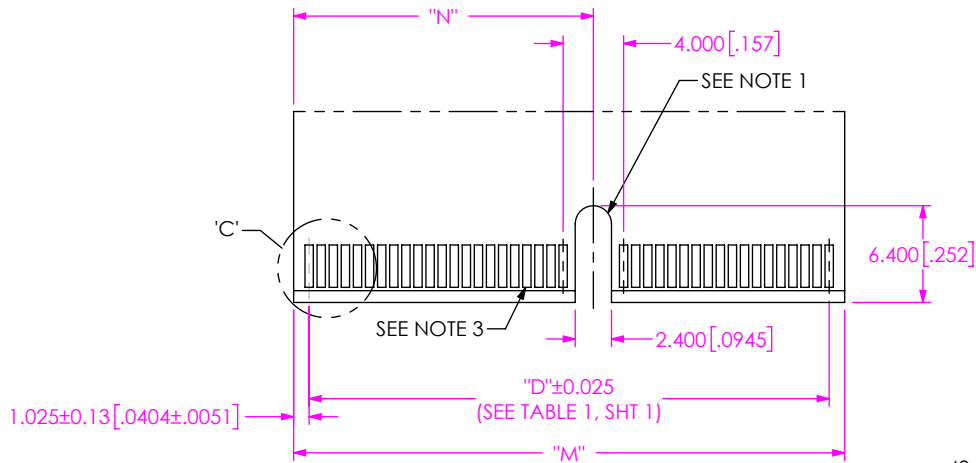

FIG 5  
-40 POSITION SHOWN  
(FOR POSITION: -09, -13, -25, -40, -49, -50, -60, -09-L2, -13-L2, -25-L2, -49-L2)

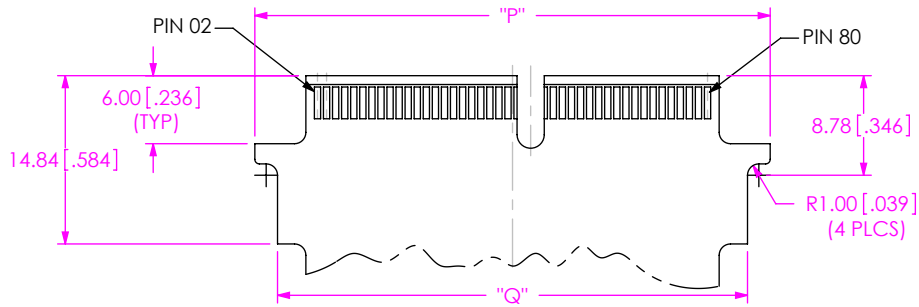
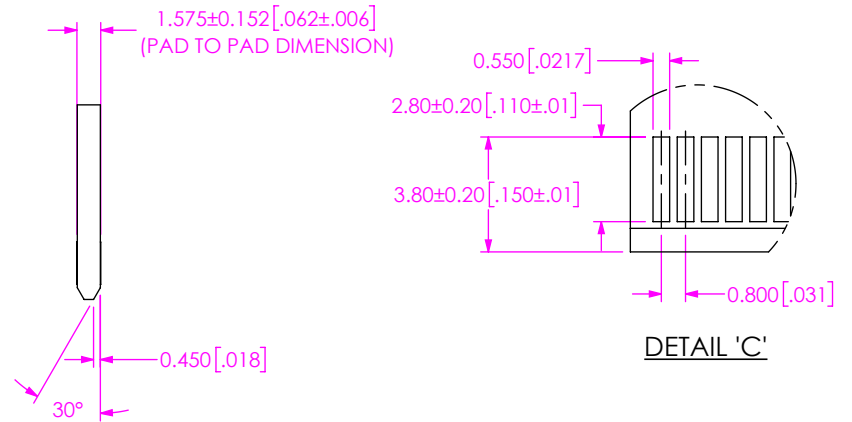
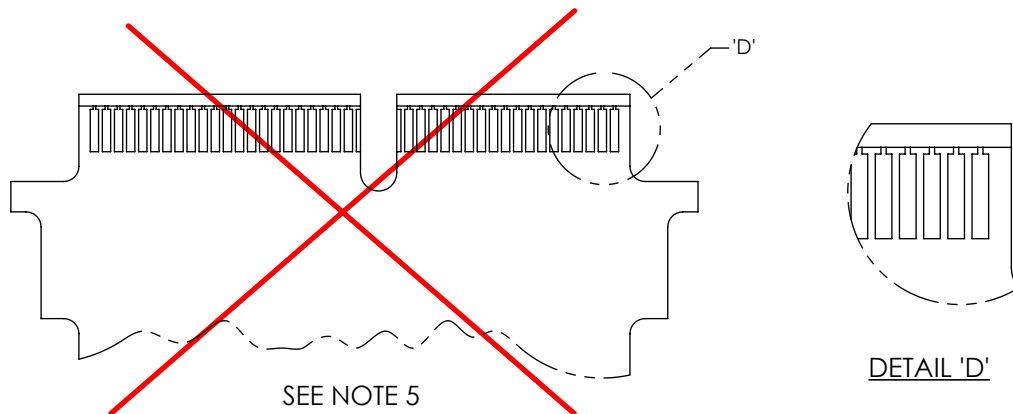

FIG 7  
-40 POSITION WITH -BL OPTION SHOWN  
(SAME AS FIG 5, EXCEPT AS SHOWN)  
(FOR POSITION: -09, -13, -25, -40, -49, -50, & -60)

TABLE 2				
No OF POSITIONS	"M"	"N"	"P"	"Q"
10	9.25 [0.364]	N/A	N/A	N/A
20	17.25 [0.679]	N/A	N/A	N/A
30	25.25 [0.994]	N/A	N/A	N/A
09	11.65 [0.459]	5.43 [0.214]	N/A	N/A
13	14.85 [0.585]	7.03 [0.277]	N/A	N/A
25	24.45 [0.963]	7.03 [0.277]	N/A	N/A
40	36.45 [1.435]	19.83 [0.781]	N/A	N/A
49	43.65 [1.719]	23.83 [0.938]	N/A	N/A
50	44.45 [1.750]	23.83 [0.938]	N/A	N/A
60	52.45 [2.065]	27.83 [1.095]	N/A	N/A
09-BL	11.65 [0.459]	5.43 [0.214]	20.65 [0.813]	16.65 [0.656]
13-BL	14.85 [0.585]	7.03 [0.277]	23.85 [0.939]	19.85 [0.781]
25-BL	24.45 [0.963]	7.03 [0.277]	33.45 [1.317]	29.45 [1.159]
40-BL	36.45 [1.435]	19.83 [0.781]	45.45 [1.789]	41.45 [1.632]
49-BL	43.65 [1.719]	23.83 [0.938]	52.65 [2.073]	48.65 [1.915]
50-BL	44.45 [1.750]	23.83 [0.938]	53.45 [2.104]	49.45 [1.947]
60-BL	52.45 [2.065]	27.83 [1.095]	61.45 [2.419]	57.45 [2.262]
09-L2	11.65 [0.459]	5.43 [0.214]	N/A	N/A
13-L2	14.85 [0.585]	7.03 [0.277]	N/A	N/A
25-L2	24.45 [0.963]	7.03 [0.277]	N/A	N/A
49-L2	43.65 [1.719]	23.83 [0.938]	N/A	N/A



NOTES:

1. -10, -20 AND -30 CARDS HAVE NO SLOT.
2. ALL DIMENSIONS ARE SYMMETRIC ABOUT THE CENTERLINE.
3. PLATING TO BE .000030 INCHES GOLD WITH A HARDNESS OF 130-200 KNOOP PER ASTM B 488 TYPE 2, GRADE C.
4. NOTE DELETED.
5. FOR PROPER CONTACT REGISTRATION, PLATING BUS TIE TO BE THE WIDTH OF THE EDGE FINGER.
6. FOR APPLICATIONS REQUIRING INVERTED REFLOW SOLDERING, USE OF AN EPOXY ADHESIVE IS RECOMMENDED.

**Z** PROPRIETARY NOTE  
THIS DOCUMENT CONTAINS CONFIDENTIAL AND PROPRIETARY INFORMATION AND ALL DESIGN, MANUFACTURING, REPRODUCTION, USE, PATENT RIGHTS AND SALES RIGHTS ARE EXPRESSLY RESERVED BY SAMTEC, INC. THIS DOCUMENT SHALL NOT BE DISCLOSED, IN WHOLE OR IN PART, TO ANY UNAUTHORIZED PERSON OR ENTITY NOR REPRODUCED, TRANSFERRED OR INCORPORATED IN ANY OTHER PROJECT IN ANY MANNER WITHOUT THE EXPRESS WRITTEN CONSENT OF SAMTEC, INC.



520 PARK EAST BLVD, NEW ALBANY, IN 47150  
PHONE: 812-944-6733 FAX: 812-948-5047  
e-Mail info@SAMTEC.com code 55322