

PRESSURE TRANSDUCERS WITH AMP. PA-100

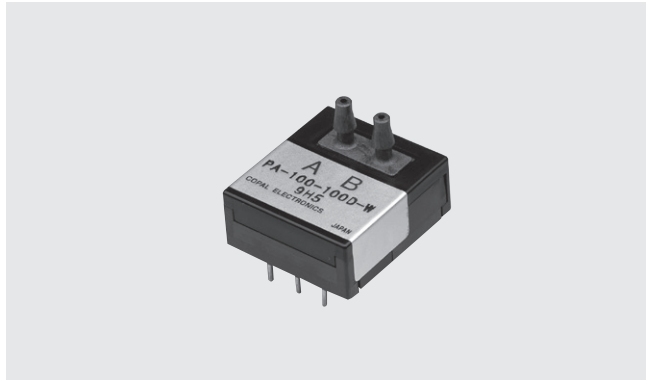

FEATURES

- Covers low pressure range
- Built-in a compact amplifier circuit
- Measures differential pressure

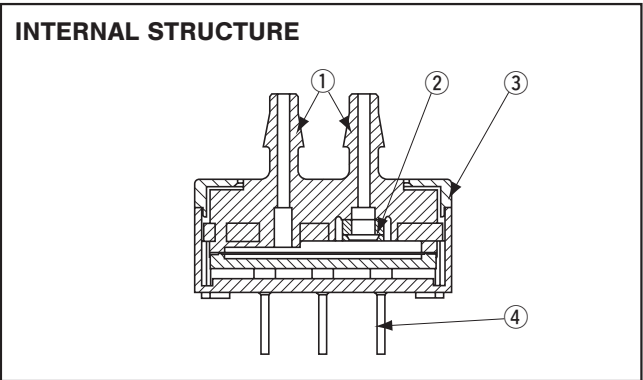

Part name	Material
① Pressure Port	LCP (Liquid crystal polymer)
② Sensor chip	Silicone
③ Housing	POM (Polyoxymethylene) PPS (Polyphenylene sulphide)
④ Terminal pin	Brass + Tin-plated

MODEL NUMBER DESIGNATION

PA-100-100D-S

Series name

Rated pressure range

100D-S : 0 ~ 1 kPa {102 mmH₂O}
 200D-S : 0 ~ 2 kPa {204 mmH₂O}
 500D-S : 0 ~ 5 kPa {510 mmH₂O}
 100D-W : -1 ~ 1 kPa {± 102 mmH₂O}
 200D-W : -2 ~ 2 kPa {± 204 mmH₂O}
 500D-W : -5 ~ 5 kPa {± 510 mmH₂O}

LIST OF MODEL NUMBERS

Pressure reference	Differential					
	kPa Rated pressure range	0 ~ 1	0 ~ 2	0 ~ 5	- 1 ~ 1	- 2 ~ 2
Model number	PA-100-100D-S	PA-100-200D-S	PA-100-500D-S	PA-100-100D-W	PA-100-200D-W	PA-100-500D-W

※ Verify the above model numbers when placing orders.

PA-100

PRESSURE TRANSDUCERS WITH AMP.

STANDARD SPECIFICATIONS

● Unless otherwise specified, the specs are defined at an ambient temperature of 25±5 °C and excitation voltage of 5 VDC.

Item		Model number	PA-100					
			100D-S	200D-S	500D-S	100D-W	200D-W	500D-W
General specifications	Pressure reference		Differential					※ 1
	Rated pressure range	kPa	1	2	5	± 1	± 2	± 5
	Maximum pressure	kPa	5	10	25	± 5	± 10	± 25
	Break-down pressure	kPa	50					
	Line pressure	kPa	50					
	Operating temp. range	°C	- 20 ~ 70					
	Compensated temp. range	°C	0 ~ 50					
	Operating humidity	%RH	35 ~ 85 (No condensation)					
	Storage temp.	°C	- 20 ~ 80 (Atmospheric pressure, humidity 65 %RH maximum)					
	Pressure medium		Non-corrosive gases					
	Insulation resistance	MΩ minimum	100 (50 VDC)					
	Dielectric strength		50 VAC, 60 s (Leakage current 1 mA maximum)					
	Pressure port	mm	∅ 2.5					
	Net weight	g	Approx. 8					
Power	Supply voltage	V DC	5 ± 10 %					
	Consumption current	maximum	5 mA					
Analog output	Output voltage	V	0.5 ~ 4.5					
	Zero voltage	※ 3 V	0.5 ± 0.08			2.5 ± 0.08		
	Span voltage	※ 3 V	4.0 ± 0.08			2.0 ± 0.08		
	Output current	mA maximum	0.5 (Load resistance 10 kΩ minimum)					
	Linearity/Hysteresis	%F.S.	± 0.5					
	Thermal error 0 ~ 50 °C (Reference temp.: 25 °C)	ZERO %F.S.	± 5	± 3	± 2	± 5	± 3	± 2
		SPAN %F.S.	± 2					
※ 2	Response	ms	5					
	Gravitational effect (From vertical position to horizontal position)	%F.S. max.	- 2	- 1	- 0.4	- 2	- 1	- 0.4

※ 1 PA-100 - □□□ D-S pressure range Pressure A port - B port = 0 ~ Rated pressure range
PA-100 - □□□ D-W pressure range Pressure A port - B port = - Rated pressure range ~ Rated pressure range

※ 2 Defined at 5 V of supply voltage.

※ 3 The zero and span voltages vary in proportion to the supply voltage.

PA-100 PRESSURE TRANSDUCERS WITH AMP.

ENVIRONMENTAL CHARACTERISTICS

Test item	Test conditions (At 25 ± 5 °C)	Permissible change
Vibration	10 ~ 500 Hz, 1.5 mm maximum/49 m/s ² , 3 directions for 2 hours each	Zero voltage/Span voltage: ± 2 %F.S. (100D/200D) maximum and ± 1 %F.S. (500D) each
Shock	490 m/s ² , 3 directions for 3 times each	
Pressure cycling	0 ~ Rated pressure, 10 ⁶ cycles	
Moisture resistance	40 °C, 90 ~ 95 %RH, 240 hrs.	

OUTPUT VOLTAGE VS PRESSURE

PA-100 - □□□D-S type

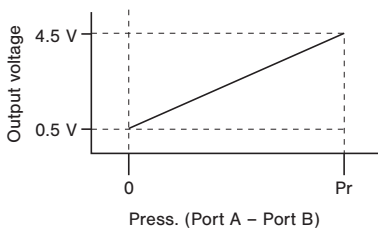

PA-100 - □□□D-W type

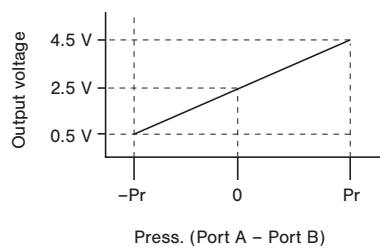

Pin	Connection
1	Power ⊕
2	Output
3	Common
4	N.C.
5	N.C.

OUTLINE DIMENSIONS

Unless otherwise specified, tolerance : ± 0.5 (Unit: mm)

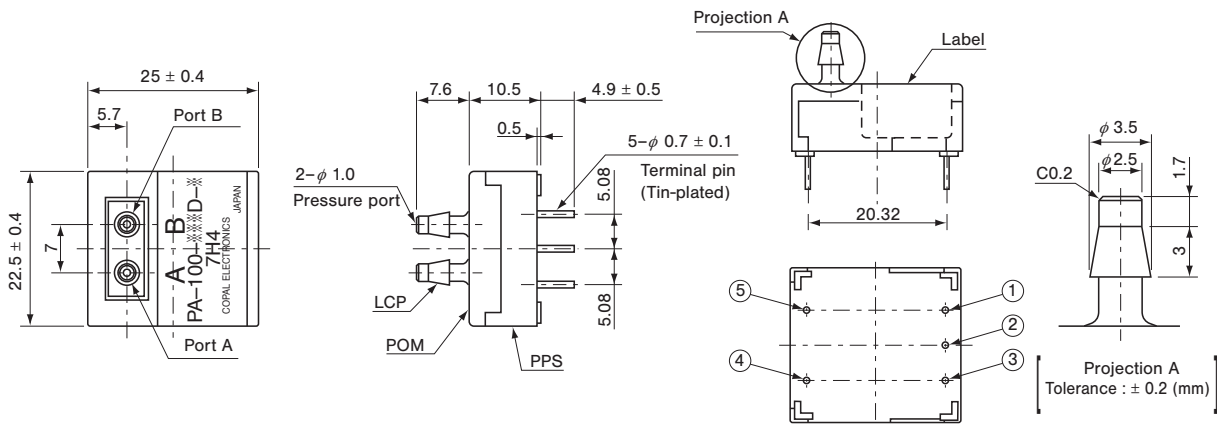

INTERNAL ELECTRICAL SCHEMATICS

