

THIS COPY IS PROVIDED ON A RESTRICTED BASIS AND IS NOT TO BE USED IN ANY WAY DETRIMENTAL TO THE INTERESTS OF PANDUIT CORP.

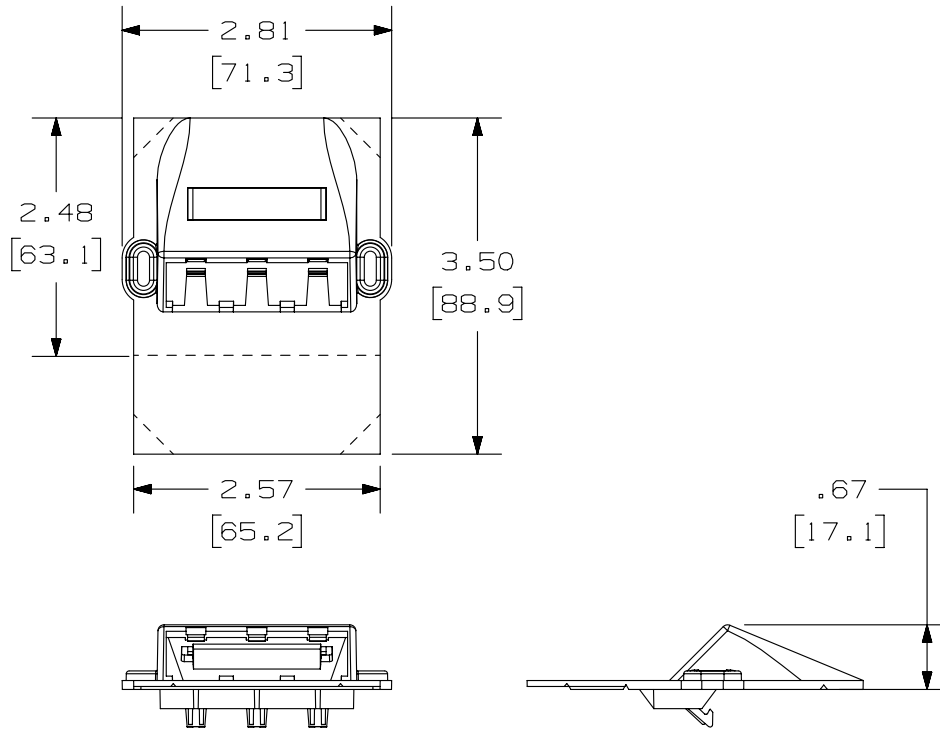

PANDUIT P/N	WEIGHT
CFPGFB3**	.32 LB/10 PCS (144.4 g/10 PCS)

NOTES:

1. SEE CURRENT CATALOG FOR ADDITIONAL PART NUMBER SUFFIXES TO INDICATE COLOR AND OR PACKAGE QUANTITY.
2. SEE CATALOG FOR COMPLETE LIST OF PARTS APPLICABLE FOR USE WITH THIS PART.
3. DASHED LINES INDICATE BREAK OFF LINES.
4. DIMENSIONS IN [] ARE IN METRIC.
5. PART INCLUDES:
 - 1- FLOOR BOX PLATE
 - 1- LABEL
 - 1- LABEL COVER

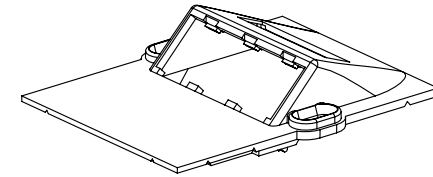

ACKERMANN IS A TRADEMARK OF NOVAR PLC,
WEYBRIDGE, SURREY, UNITED KINGDOM

PART NUMBER		CFPGFB3**	
TITLE			
MINI-COM 3 POSITION ACKERMANN FLOOR BOX		FACEPLATE	
CUSTOMER DRAWING			
ITEM REVISION NAME		M00130BA/02	
DATASET FILE NAME		M00130BA_DC/02B	
UNLESS OTHERWISE SPECIFIED, DIMENSIONAL TOLERANCES ARE: IN [mm]		MATERIAL:	
.x ± .xx ± .03 [.8]		.xxx ± .010 [.3]	
ANGLES ±		ABS	
DRAWING NUMBER:		00130-02	
DRAWN BY		CHK	
JSP		FJD	
DATE		SCALE	
3-19-98		NONE	
DESCRIPTION		SHT 1 OF 1	
ECN		SIZE	
00130-02		A	

REV	DATE	BY	CHK	APR	DESCRIPTION	ECN
1	4/8/14	JSP	REFR	MMR	A. REVISED DRAWING TITLE BLOCK.	00130-02
R	3-19-98	JSP	FJD	FJD	RELEASED TO PRODUCTION	00130-02

D10100DA/14

2

1

2

1