

INSTALLATION INSTRUCTIONS FOR THE **MICRO SWITCH BX SERIES** EXPLOSION-PROOF LIMIT SWITCHES

50083427

Issue 13



Multiple language versions of installation instructions and other documents are available on Honeywell's website. To access:

1. Go to <http://sensing.honeywell.com/hazardousareaswitches>
2. Select the product's instructions from the installation instruction section.

Installationsanweisungen und andere Dokumente stehen in mehreren Sprachen auf der Honeywell-Website zur Verfügung. So greifen Sie darauf zu:

1. Gehen Sie auf die Webseite <http://sensing.honeywell.de/hazardousareaswitches>
2. Wählen Sie im Bereich "Installationsanweisungen" die zum entsprechenden Produkt gehörenden Anweisungen aus.

Versiones de las instrucciones de instalación y otros documentos se encuentran disponibles en el sitio de internet de Honeywell en múltiples idiomas. Para acceder:

1. Vaya a <http://sensing.honeywell.com/hazardousareaswitches>
2. Seleccione las instrucciones del producto en la sección de instrucciones de instalación.

Les instructions d'installation et d'autres documents sont disponibles dans plusieurs langues sur le site Web d'Honeywell. Procédure d'accès :

1. Accédez à la page <http://sensing.honeywell.com/hazardousareaswitches>
2. Sélectionnez les instructions relatives au produit qui vous intéresse dans la section « Installation Instructions

Sul sito Web di Honeywell sono disponibili istruzioni per l'installazione in più lingue e altra documentazione. Per accedere:

1. Andare a <http://sensing.honeywell.com/hazardousareaswitches>
2. Selezionare le istruzioni per il prodotto nella sezione istruzioni per l'installazione.

As versões em diversos idiomas das instruções de instalação e outros documentos estão disponíveis no site da Honeywell. Para acessar:

1. Vá para <http://sensing.honeywell.com/hazardousareaswitches>
2. Selecione as instruções do produto na seção de instruções de instalação.

多语种安装指南和其他文档均可从霍尼韦尔的网站上获取。访问网站:

1. 前往 <http://sensing.honeywell.com/hazardousareaswitches>
2. 从安装指南部分选择具体的产品指南。

설치 지침서 및 기타 설명서의 다국어 언어 버전은 Honeywell의 웹사이트에서 구할 수 있습니다. 액세스 방법:

1. <http://sensing.honeywell.com/hazardousareaswitches>로 이동합니다.
2. 설치 지침 섹션에서 제품 지침서를 선택합니다.

На веб-сайте Honeywell имеются инструкции по установке и другие документы на различных языках. Для доступа к ним выполните следующие действия.

1. Перейдите по адресу <http://sensing.honeywell.com/hazardousareaswitches>
2. Выберите инструкции для изделия в разделе инструкций по установке.

⚠️ WARNING

PERSONAL INJURY

DO NOT USE these products as safety or emergency stop devices or in any other application where failure of the product could result in personal injury.

Failure to comply with these instructions could result in death or serious injury.

⚠️ WARNING

OPENING PRODUCTS HAZARD

DO NOT OPEN these products when energized or in a flammable gas atmosphere.

Failure to comply with these instructions could result in death or serious injury.

⚠️ WARNING

IMPROPER CONDUIT THREAD USE

DO NOT USE any other conduit thread than the one identified on the product. Verify that the mating threaded fitting is identical with the conduit thread shown on the product nameplate.

Failure to comply with these instructions could result in death or serious injury.

⚠️ WARNING

During installation, suitable certified cable entry and closing device approved by Explosion Test Lab with Ex marking "Ex IIC" shall be used and correctly installed. The conduit size should be NPT 1/2", NPT 3/4", M20, PG13.5, or PF1/2". Cable entry for redundancy use should be well and effectively blocked by closing device.

Honeywell

MICRO SWITCH EXPLOSION-PROOF LIMIT SWITCH BX SERIES

Issue 13
50083427

⚠️ WARNING

During installation, BX Series limit switches should not be subjected to a corrosive atmosphere that could corrupt the enclosure, thereby avoiding immediate or future corrosion of the switch's enclosure.

⚠️ WARNING

Do not replace any switch components with those from another switch or replacement part without consulting Honeywell technical support.

⚠️ WARNING

During the switch's installation, use, and maintenance, observe the following standards: GB15577; GB/T3836.13; GB/T3836.15; GB/T3836.16; and GB50257.

⚠️ WARNING

The equipment has a non-conducting coating and may generate an ignition-capable level of electrostatic charges under certain extreme conditions. The user should ensure that the equipment is not installed in a location where it may be subjected to external conditions (such as high pressure steam) which might cause a build up of electrostatic charges on non-conducting surfaces. Additionally, cleaning of the equipment should be done with a damp cloth.

⚠️ WARNING

Any cable glands used with this product shall be provided with protection d for hazardous location category IIC with certificate, according to TP TC 012/2011.

dc voltage	Make & Break Inductive	Resistive
120	0.25	0.80
240	0.15	0.40
Q300/125V	0.55	-
Q300/250V	0.27	-

These products meet the following Protection Classes along with complying with Essential Health and Safety Standards as mentioned in Table 2.

TABLE 2. CERTIFICATIONS

Certification	IECEX	ATEX	INMETRO
Certificate number	IECEX SIR 07.0102X	SIRA 00ATEX1037X	TÜV 14.0556 X
Protection Class	II 2 GD	II 2 GD	-
	Ex db IIC T6 Gb	Ex db IIC T6 Gb	Ex db IIC T6 Gb
	Ex tb IIIC T85°C Db	Ex tb IIIC T85°C Db	Ex tb IIIC T85°C Db
	-	-	IP6X
	-12°C ≤ Tamb ≤ +70°C (Fluorocarbon Seal)		
-40°C ≤ Tamb ≤ +70°C (Fluorosilicone Seal)			
Health and Safety Standards	IEC 60079-0	EN 60079-0	ABNT NBR IEC 60079-0
	IEC 60079-1	EN 60079-1	ABNT NBR IEC 60079-1
	IEC 60079-31	EN 60079-31	ABNT NBR IEC 60079-31 ABNT NBR IEC 60529

SPECIAL CONDITIONS FOR SAFE USE

Honeywell explosion-proof switches are designed specifically for use in hazardous location applications. The BX enclosure is sealed for protection against corrosion, water, dust and oil as defined in NEMA 1, 3, 4, 4X, 6, 13, and IP67 (per IEC60529). The temperature rating for these products depends upon the seal material used. Products using a fluorosilicone seal have a rating of -40°C [-40°F] to 70°C [158°F]. Products using a fluorocarbon seal have a rating of -12°C [10°F] to 70°C [158°F]. MICRO SWITCH BX switches are rated according to the electrical ratings detailed in Table 1.

TABLE 1. ELECTRICAL RATINGS: 10 A CONT.

ac voltage	Single Pole		Double Pole		Power factor
	Break	Make	Break	Make	
120	60	6	30	3	.35
240	30	3	15	1.5	.35
480	15	1.5	7.5	.75	.35
600	12	1.2	6	6	.35
A300/120V	-	-	60	6	.30
A300/240V	-	-	30	3	.30

The maximum construction gap (ic) is less than that required by Table 2 of EN/IEC60079-1, clause 5.2.2 as detailed below in Table 3.

The equipment has a non-conducting coating and may generate an ignition-capable level of electrostatic charges under certain extreme conditions. The user should ensure that the equipment is not installed in a location where it may be subjected to external conditions (such as high pressure steam) that might cause a build up of electrostatic charges on non-conducting surfaces. Additionally, cleaning of the equipment should be done with a damp cloth.

TABLE 3. FLAME PATH MEASUREMENTS

Flame path	Max. gap	Comment
Push rod & bearing	0,076 mm	Cylindrical spigot joint
Bearing & housing	0,02 mm	Cylindrical spigot joint

BX with conduit types 1/2-14NPT, 3/4-14NPT also meet the North American Hazardous Locations Designation: NEMA 7 - Class I, Groups B, C and D; NEMA 9 - Class II, Groups E, F and G and comply with UL Standard: UL 894, CSA Standard: C22.2 No. 25-1966, C22.2 No. 30-M1986.

The BX is ideal for outdoor use or in adverse environments where a combination of explosion-proof plus sealing requirements are needed. To comply with explosion proof requirements the BX has flame paths within the housing, which cool exploding gases below the ignition temperature before they reach explosive gases surrounding the housing. Flame paths on the BX are (1) an extended plunger between the switch cavity and head and (2) the cover-housing threads on the front of the switch.

MOUNT, ADJUST, WIRE MOUNTING

Note mounting dimension drawings for hole locations (Figure 9, page 3). The BX is directly interchangeable with the LSX explosion-proof limit switches: Adapter plate is not required.

ADJUSTING INSTRUCTIONS

To give flexibility in application, the user can perform the adjustments described below in any order before wiring the unit.

ACTUATOR HEAD

The actuator head may be positioned in any of four directions.

1. Loosen the four captive head screws.
2. Place head in the desired position.
3. Securely tighten the four screws to 1,4 Nm to 1,8 Nm [12 in-lb to 16 in-lb] (Figure 1).

REVERSING THE ROLLER LEVER

Except for the offset roller levers, the roller arm may be reversed to face the roller to the inside or outside of the arm.

Figure 1.

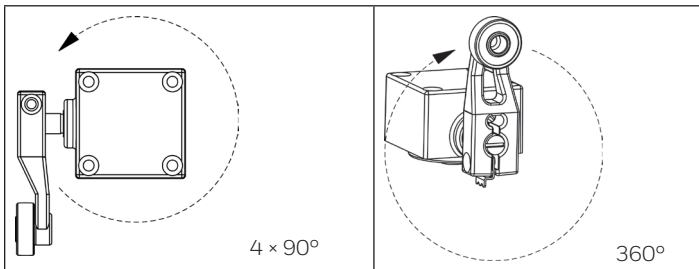

Figure 2.

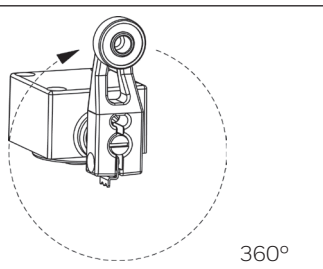
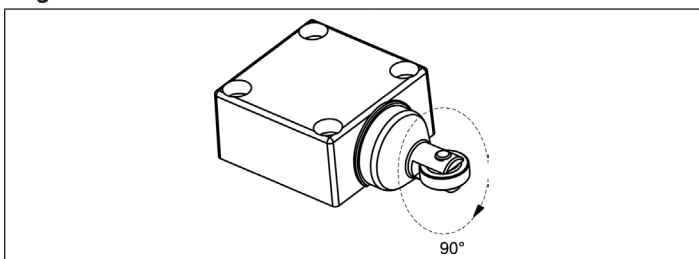

Figure 3.



POSITIONING LEVER

The lever on rotary actuated units is adjustable to any position through 360° around the shaft.

1. Loosen the cap screw with 9/64-inch hexagon key wrench.
2. Move lever to desired position.
3. Securely tighten screw until teller tab can no longer be moved by hand.
4. Tighten screw another 1/8 to 1/4 turn to assure lever is tight on the shaft (Figure 2).

A 9/64-inch hex key wrench is provided in the adjusting tool set LSZ4005.

ADJUSTABLE LENGTH LEVERS

To adjust the length of the adjustable length levers, a 9/64-inch hexagon key wrench is required. A 9/64-inch key wrench is provided in the adjusting tool set LSZ4005.

TOP ROLLER PLUNGER

Position the top roller plunger in the desired roller plane, by adjusting the head as explained under actuator head.

SIDE ROLLER PLUNGER

Grasp the plunger with a pair of pliers and rotate to the desired horizontal or vertical position (Figure 3).

CHANGING DIRECTION OF ACTUATION SIDE ROTARY

Catalog listings with the first three letters BXA, BXH, BXL, BXP, and BXR may be adjusted to operate clockwise, counter-clockwise or both. Catalog listings BXM (center neutral) and BXN (maintained) operate in both directions but cannot be changed. To change the actuation direction for the BXA, BXH, BXL, BXP, and BXR, follow these steps:

1. Loosen the head screws and remove the head from the switch housing.
2. On the bottom of the head, insert a screwdriver in the slot provided (Figure 4) and lift open the hinged cover.
3. Referring to Figure 5, slide the cam all the way back, so cam is free to rotate on the shaft.
4. Using a screwdriver or similar tool, rotate the cam to the desired actuating position (Figure 6).
5. Slide the cam all the way forward to its original position, and close the hinged cover.
6. Replace the operating head on the switch housing and securely tighten the head screws to 1,4 Nm to 1,8 Nm [12 in-lb to 16 in-lb].

MICRO SWITCH EXPLOSION-PROOF LIMIT SWITCH BX SERIES

Issue 13
50083427

Figure 4.

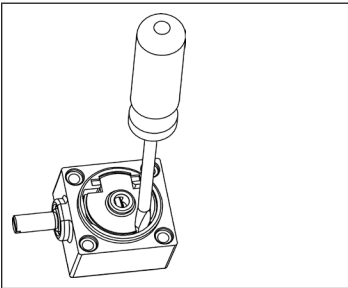

Figure 5.

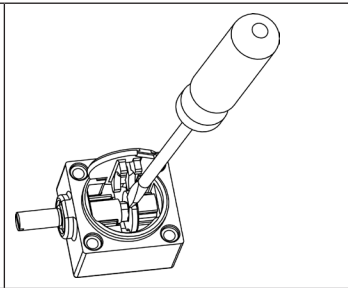
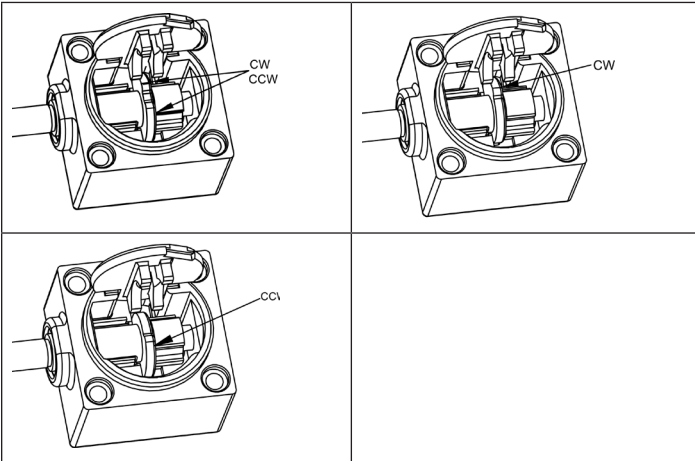

Figure 6.



TOP ROTARY

Follow these steps to change the operating direction of the BXB type switch:

1. Loosen the head screws and remove head from the switch housing.
2. From the bottom of the head, grasp the end of the pin plunger (Figure 7) and remove the pin. It may be necessary to rotate the actuating shaft to expose the end of the pin plunger.
3. Referring to Figure 8, select the correct pin plunger position for the desired direction of actuation.
4. Insert the pin plunger in the position providing the desired direction of actuation.
5. Replace the operating head on the switch housing and securely tighten the head screws to 1,4 Nm to 1,8 Nm [12 in-lb to 16 in-lb].

Figure 7.

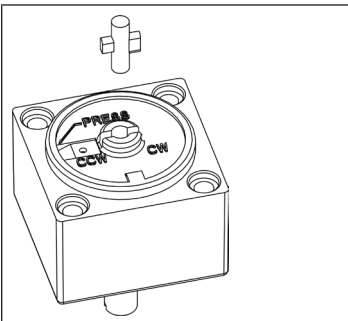

Figure 8.

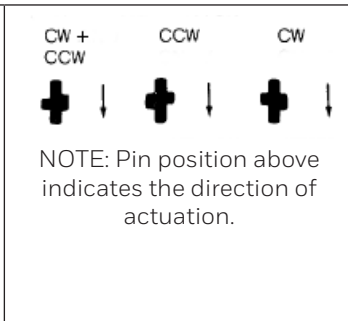
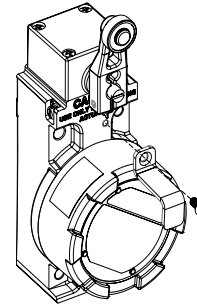

Figure 9. Exploded View of Clamp and Screw



REPLACEMENT LEVERS

Use only non-sparking levers to retain the explosion proof qualities.

WIRING INSTRUCTIONS

1. Unscrew cover to expose the switching element for wiring or replacement. To aid in cover removal, a screwdriver or bar may be used on the wrenching lugs. Use up to size #12 AWG solid or stranded wire to connect to the pressure type connector terminals. Stripped wire ends or any spade and ring connector that will fit the terminals may be used. Spades may be up to 7,9 mm [0.312 in] wide, rings up to 7,9 mm [0.312 in] diameter. With spade or ring type connections preinsulated connectors or heat-shrinkable tubing should be used to provide insulation between terminals. Conduit size, electrical ratings and circuit diagram are shown on the nameplate. Wire the double pole units by connecting lead wires to the terminals nearest the conduit opening first. An internal grounding screw is located on the right side; an external grounding screw is located on the upper left side. Torque all terminal screws and grounding screws to 1 Nm to 1,8 Nm [9 in-lb to 16 in-lb]. Reassemble cover and torque to 10 Nm [90 in-lb].
2. Put cover locking clamp on circular cover and tighten the flat head cross recessed screw to 1,5 Nm to 1,8 Nm [13.27 in-lb to 16 in-lb]. (See Figures 9 and 10)
3. The internal grounding terminal must be used for the equipment grounding connection, and the external terminal is for supplementary bonding connection where local codes or authorities permit or require such connections. (See Figure 11)

Figure 10. Wiring Instructions

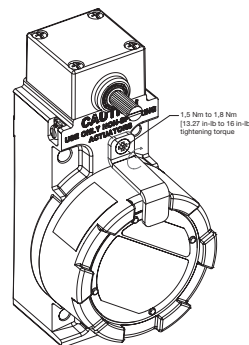
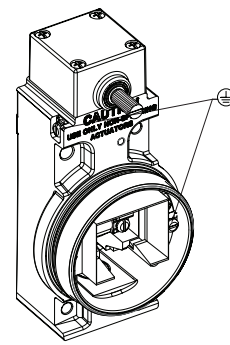
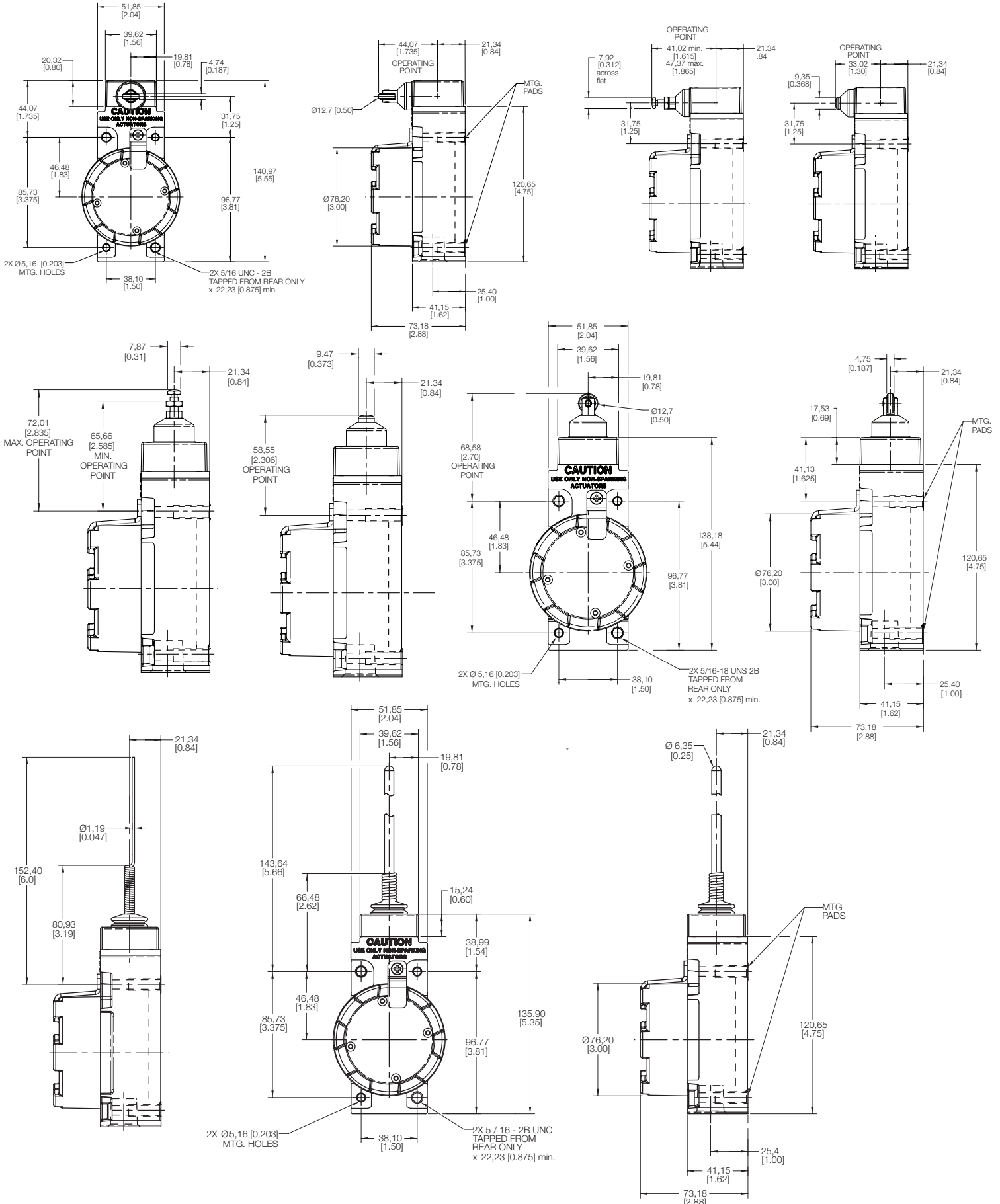

Figure 11. Wiring Instructions



MICRO SWITCH EXPLOSION-PROOF LIMIT SWITCH BX SERIES

Issue 13
50083427



MICRO SWITCH EXPLOSION-PROOF LIMIT SWITCH BX SERIES

Issue 13
50083427

Honeywell

EU Declaration of Conformity

Honeywell International Inc. hereby declare that the products identified below conform to the essential requirements of the EU Directive(s) listed below and that the products supplied are in conformity with the type described in any EU Type Examination Certificate (EU TEC) identified below. This declaration is issued under the sole responsibility of the manufacturer.

Manufacturer: Honeywell International Inc.
315 E. Stephenson St.
Freeport, Illinois 61032
USA

Product: Limit Switch - BX
BX and BX2 Series

<u>Directive (Amendments)</u>	<u>Conformity Details</u>
ATEX 2014/34/EU	Standards applied: EN IEC 60079-0:2018 EN 60079-1:2014 EN 60079-31:2014
	EU TEC No: SIRA 00ATEX1037X
	Notified Body: Notified Body ID 2813 CSA Group Netherlands BV Utrechtseweg 310, 6812 AR Arnhem, Netherlands
	ATEX Markings II 2 GD Ex db IIC T6 Gb, Ex tb IIIC T85C Db

Signed on behalf of Honeywell International Inc.:

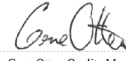

Gene Ottes, Quality Manager, Freeport, IL USA

DoC No: A230
Original Issue Date: 2000

DoC Issue: 15

DoC Date: 19-December-2022

Page 1 of 2

Honeywell

UK Declaration of Conformity

Honeywell International Inc. hereby declare that the products identified below conform to the essential requirements of the UKSI 2016:1107 (as amended) and that the products supplied are in conformity with the type described in any UK Type Examination Certificate (UK TEC) identified below. This declaration is issued under the sole responsibility of the manufacturer.

Manufacturer: Honeywell International Inc.
315 E. Stephenson St.
Freeport, Illinois 61032
USA

Product: Limit Switch - BX
BX and BX2 Series

<u>Directive (Amendments)</u>	<u>Conformity Details</u>
Equipment and Protective Systems Intended for use in Potentially Explosive Atmospheres Regulations	Standards applied: EN IEC 60079-0:2018 EN 60079-1:2014 EN 60079-31:2014
	UK TEC No: CSAE 21UKEX1729X
	Approved Body: Approved Body ID 0518 CSA Group Testing UK Ltd. Unit 6 Hawarden Industrial Park Hawarden, CH5 3US, UK
	Markings II 2 GD Ex db IIC T6 Gb, Ex tb IIIC T85C Db

Signed on behalf of Honeywell International Inc.:



Gene Ottes, Quality Manager, Freeport, IL USA

DoC No: B230
Original Issue Date: 2021

DoC Issue: 2

DoC Date: 19-December-2022

Page 1 of 2

WARRANTY/REMEDY

Honeywell warrants goods of its manufacture as being free of defective materials and faulty workmanship during the applicable warranty period. Honeywell's standard product warranty applies unless agreed to otherwise by Honeywell in writing; please refer to your order acknowledgment or consult your local sales office for specific warranty details. If warranted goods are returned to Honeywell during the period of coverage, Honeywell will repair or replace, at its option, without charge those items that Honeywell, in its sole discretion, finds defective. **The foregoing is buyer's sole remedy and is in lieu of all other warranties, expressed or implied, including those of merchantability and fitness for a particular purpose. In no event shall Honeywell be liable for consequential, special, or indirect damages.**

While Honeywell may provide application assistance personally, through our literature and the Honeywell web site, it is buyer's sole responsibility to determine the suitability of the product in the application.

Specifications may change without notice. The information we supply is believed to be accurate and reliable as of this writing. However, Honeywell assumes no responsibility for its use.

FOR MORE INFORMATION

Honeywell Sensing and Safety Technologies services its customers through a worldwide network of sales offices and distributors. For application assistance, current specifications, pricing or the nearest Authorized Distributor, visit [our website](#) or call:

USA/Canada	+1 302 613 4491
Latin America	+1 305 805 8188
Europe	+44 1344 238258
Japan	+81 (0) 3-6730-7152
Singapore	+65 6355 2828
Greater China	+86 4006396841

Honeywell

Sensing and Safety Technologies

830 East Arapaho Road
Richardson, TX 75081
www.honeywell.com

50083427-13-EN | 13 | 02/23
© 2023 Honeywell International Inc. All rights reserved.

