

PRE - ASSEMBLY INSTRUCTIONS:

Caution: Check gasket on top of base units for damage before assembly. If cut or torn, contact Hammond Manufacturing for immediate replacement.

Note: When assembling total modular system build from the floor up for assembly ease. Plinth > Base Unit > Desk Unit > Turret

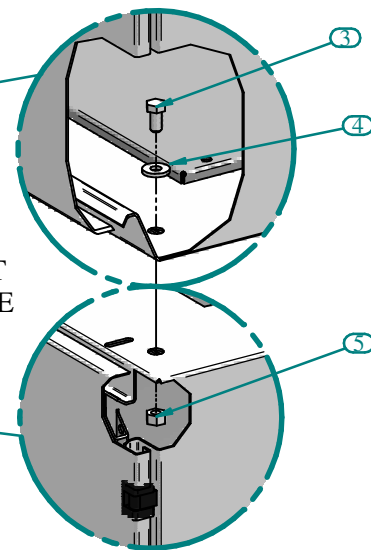

ASSEMBLY INSTRUCTIONS:

- A) Open or remove doors on base unit for ease of assembly. This will allow for visual alignment of mating parts.
- B) Remove .5 dia knockouts in base units before assembly.
- C) Align base #1 (item 1) over top opening in base #2 (item 2). Side edges of base units are to be flush.
- D) Front and rear holes in base unit bottom are to be aligned with mounting holes on base unit top.
- E) Once the base #1 is seated properly on the base #2. Assemble using 3/8-16 x .75 hex head bolts and 3/8 nuts and sealing washers (item 3, 4 & 5). Torque bolts and nuts to 180 in/lbs.

PARTS LIST

ITEM No.	DESCRIPTION	QTY
1	BASE UNIT #1 (TOP)	1
2	BASE UNIT #1 (BOTTOM)	1
3	3/8-16 X 3/4 HEXCAP SCREW	4 or 6
4	3/8 SEALING WASHER	4 or 6
5	3/8 HEX NUT	4 or 6

TOOL BOX

