

Choose the Right Buck Converter for Your USB 3.1 Type C Powered Devices

Introduction

The new USB 3.1 Type C standard promises to dramatically simplify the connection of electronic gadgets. The new standard aims at utilizing the same Type C cable for data and power transfer between any two devices up to 100 watts. This article discusses the characteristics of the always-on buck converter, a key enabler of the handshake required between the source and sink devices to acknowledge connection and negotiate the amount of power delivered.



Figure 1. USB 3.1 Type C Cable

USB 3.1 Type C Standard

USB 3.1 Type C is a new standard which supports high data rates and increased power delivery between electronic products. USB 3.1 can deliver 10Gbps of throughput while delivering up to 3A over standard cables and up to 5A over enhanced cables. The bus voltage can be adjusted up to 20V (60W at 3A with a standard cable or 100W at 5A with an enhanced cable). Many notebook computers today require less than 100W of power, hence new models adopting a Type C connector can be charged via a USB port the way small devices are charged today.

The complexity of the USB 3.1 Type C standard requires a device to negotiate as either a power provider (source) or power user (sink) before power transfer takes place. Accordingly, Type C

cables are 'smart', requiring additional circuitry to know how to correctly route power and data. The connectors at both ends of a Type C cable are identical, allowing for reversible plug in. Each connector is also flippable, which allows it to be plugged in with either side facing up. Type C USB also allows for bi-directional power, hence a peripheral device can be charged, and the same device can also charge a host device. This promises to eliminate many proprietary power adapters and many types of USB cables, ultimately reducing the maze of wires surrounding today's desktops.

USB 3.1 Type C System

Figure 2 illustrates a typical notebook computer power management front end equipped to connect to a USB Type C cable and powered by a stack of three Lithium-Ion batteries (providing a supply voltage between 7.2V and 12.6V).

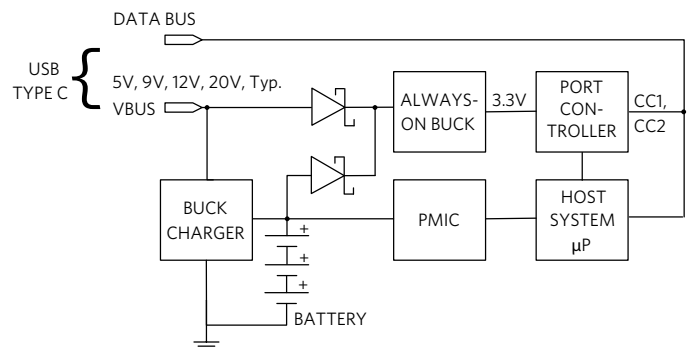

Figure 2. USB 3.1 Type C Power Management System

The power management integrated circuit (PMIC) is powered directly by the batteries, while the always-on buck converter receives power via the Schottky diodes, either from the batteries or from the USB source. In turn, the always-on buck converter powers the port controller, a device arbitrating the power exchange between the host system microprocessor (μ P) and the power source. When the USB is connected the buck charger charges the battery. The sequence below illustrates the steps necessary to recharge a dead battery:

- Step 1. Battery dead
- Step 2. USB Type C cable connected
- Step 3. USB Type C cable detects connection and provides initial 5V
- Step 4. Always-on converter wakes up and powers the port controller
- Step 5. Port controller negotiates power requirement (Example: 5A, 20V)
- Step 6. System receives required power via USB Type C cable
- Step 7. Buck charger initiates battery charge

The always-on buck converter plays a key role in all phases. It provides 3.3V out even with a relatively low input voltage (5V minus the Schottky diode drop) provided initially by the USB. During normal operation, the power source has the ability to change capabilities at any time, forcing the sinking device to renegotiate, hence the necessity for the buck converter to be always 'on'. Accordingly, the always-on buck converter should be selected to consume minimum power.

MAX77596 Always-On Buck Converter

The MAX77596 is a small, synchronous buck converter with integrated switches (T1 and T2 in Figure 3). The device is designed to deliver up to 300mA with input voltages from 3.5V to 24V, while using only 1.1µA quiescent current at no load (fixed-output version). The device can operate near dropout by running at 98% duty cycle, making it ideal for battery-powered applications.

The device offers fixed 3.3V and 5V output versions, as well as an adjustable version. The adjustable version allows the user to program the output voltage between 1V and 10V by using a resistor-divider. Frequency is fixed at 1.7MHz, which allows for small external passives and reduced output ripple. The on-chip power transistor switches warrant a small bill of materials. The device offers both forced PWM and skip modes of operation.

The MAX77596 is available in a small (2mm × 2.5mm) 10-pin TDFN package and operates across the -40°C to +85°C temperature range.

Very Low Quiescent Current

For an always-on device, low quiescent current is critical since the device is never shut down. The MAX77596 fixed output version allows most of the internal circuitry to be biased from the V_{OUT} pin (I_{BIAS} in Figure 3).

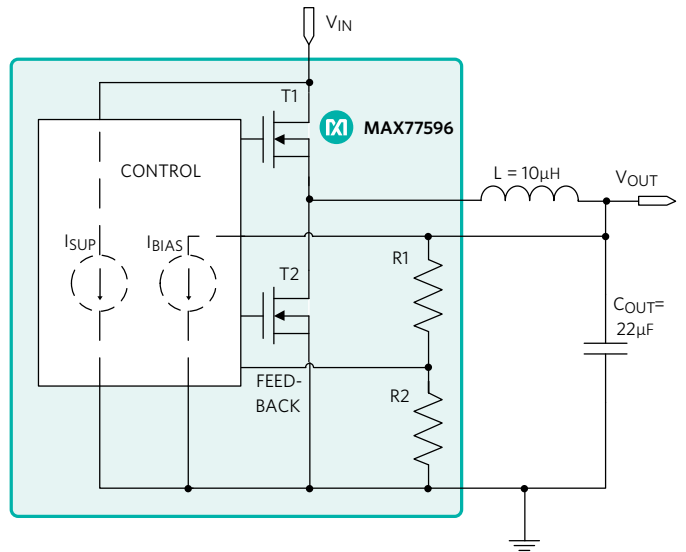

Figure 3. MAX77596 Buck Converter Fixed Output

This way only a residual current of 1.1µA (I_{SUP}) is drawn from the input pin. Figure 4 shows the temperature behavior of the supply current, I_{SUP}.

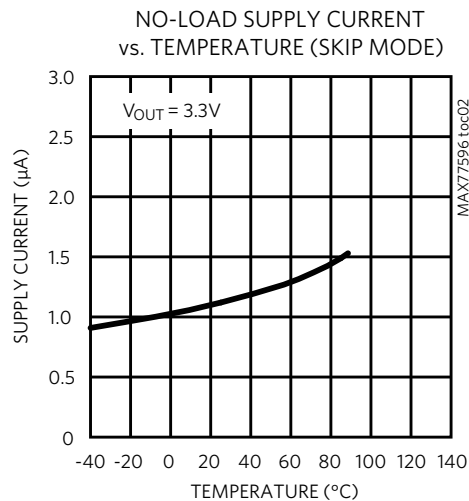

Figure 4. No-Load Supply Current vs Temperature

This clever bias arrangement makes the MAX77596 best in class for low quiescent current operation.

Buck Converter High Efficiency

Low resistance, integrated MOSFET switches enable high efficiency even at a high 1.7MHz operating frequency. The efficiency comparison in Figure 5 shows that the MAX77596 has an advantage of up to 5% versus a competitive device.

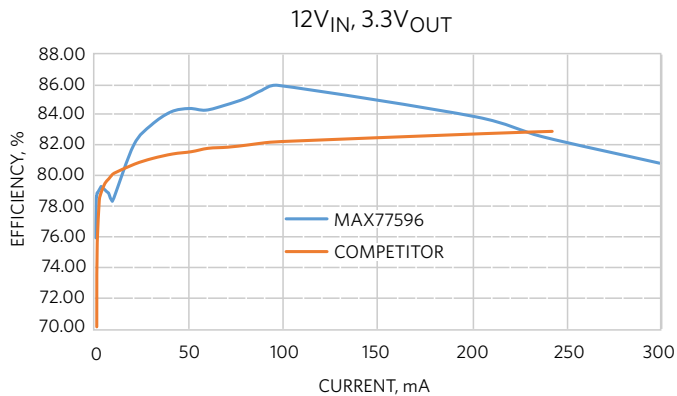

Figure 5. Efficiency Comparison

Conclusion

The USB 3.1 Type C standard allows delivery of more power to more devices with a single Type C cable. One key component in the handshake required between the source and sink devices is the always-on buck converter powering the port controller. The MAX77596, with its best-in-class low quiescent current and high efficiency, is the ideal choice to support USB Type C applications.

Learn more:

[MAX77596 24V, 300mA, Buck Converter with 1.1µA IQ](#)

Design Solutions No. 14

Need Design Support?
Call 888 MAXIM-IC (888 629-4642)

Maxim Integrated
160 Rio Robles
San Jose, CA 95134 USA
408-601-1000
maximintegrated.com

