

Choose the Right Amplifier for Your Active Antenna Design

Introduction

The automotive industry is in the midst of a widespread migration to the use of remote, shark-fin style antenna modules for unified terrestrial and satellite communications. Due to compact antenna geometries and their remote location with respect to the radio, shark-fin modules require high performance, integrated, low-noise amplifiers (LNAs) for optimal antenna performance. Prior to the proliferation of the shark-fin antenna, glass antennas (planar antenna structures printed on window glass) were the dominant technology. Glass antennas continue to be very popular and are often located on a vehicle's rear or side windows. As a result, they are remote from the radio, like a shark-fin antenna, and often employ local LNAs to maximize performance. The common use of LNAs in both shark-fin and glass antenna designs makes active antennas a very common technology in modern automobiles.



The Remote Antenna Problem

Locating the antenna remotely can impact performance in different ways, depending upon the application. In the FM band the antenna is typically matched to the RF cable impedance of 50Ω or 75Ω, enabling optimum power transfer. However, noise figure increases proportionally to the loss in the cable between the antenna and the receiver. For a long cable this may be greater than 1dB, causing an equal loss in sensitivity. Placing an LNA between the antenna and the cable largely eliminates this effect.

In the case of AM operation, remote location of the antenna affects performance in a different way, although the end result is, again, degraded sensitivity. Typical AM antennas have a very high source impedance, frequently modeled as a series capacitor with a value between 3pF and 100pF, depending upon the geometry. Any shunt capacitance in the cable linking the antenna and receiver forms a capacitive divider with the source capacitance. A lengthy cable may have more than 100pF shunt capacitance, which can dramatically attenuate the signal. Placing an LNA with a high impedance input and low impedance output between the antenna and the cable enables maximum signal transfer. For both AM and FM operation, increasing the signal level at the antenna via a remote LNA significantly decreases sensitivity to ambient noise pickup in the cable, creating a more robust radio solution.

Common Active Antenna Solutions

The performance and required features of the active antennas LNA depend upon the application. Some active antenna solutions require automatic gain control (AGC) while others use fixed-gain LNAs for the lowest cost. Some solutions provide a regulated supply voltage to the active antenna, but many operate off the battery. Some designs require especially high gain while other designs may be particularly sensitive to AGC threshold. The resulting challenge for antenna solution suppliers is to meet the wide range of industry requirements without constantly redesigning discrete solutions or using costly ICs which still require a high number of external active and passive components.

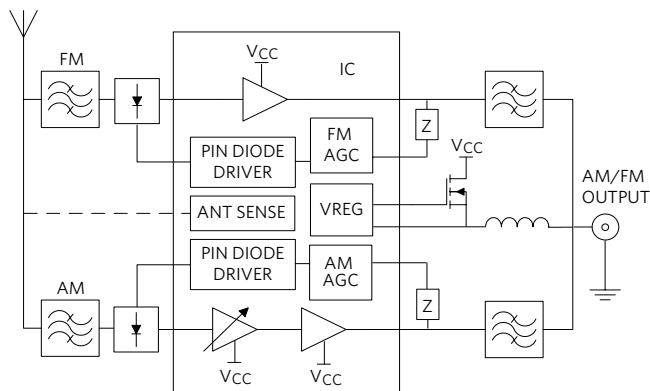

Figure 1. Active antenna solution with external components

A few vendors offer integrated AM/FM solutions for active antennas. Unfortunately, these often require external PIN diodes for AGC, a regulated supply, or an external pass transistor if operating off the battery (Figure 1).

The external components add cost and expand the solution footprint, making them barely more competitive than discrete designs. In addition to larger physical size, another drawback is that changes to the required gain, supply voltage, or footprint may require a board redesign. This in turn requires additional design resources which are always in short supply. With limited resources and space, the ideal solution for antenna providers is a high-performance, low-cost, yet flexible IC which easily meets a range of requirements without redesign, BOM changes, or board spins.

An Ideal Active Antenna Solution

An example of one such solution for active antenna designs is [MAX2180A](#), an AM/FM low-noise amplifier with selectable application configurations. MAX2180A uses a proprietary high-voltage CMOS process that integrates the AM and FM AGC, as well as a high-voltage regulator. By eliminating the need for external PIN diodes and an external regulator or pass transistor MAX2180A minimizes the total antenna solution size. The high level of integration allows the MAX2180A 4mm x 4mm TQFP package to easily fit within the smallest antenna modules.

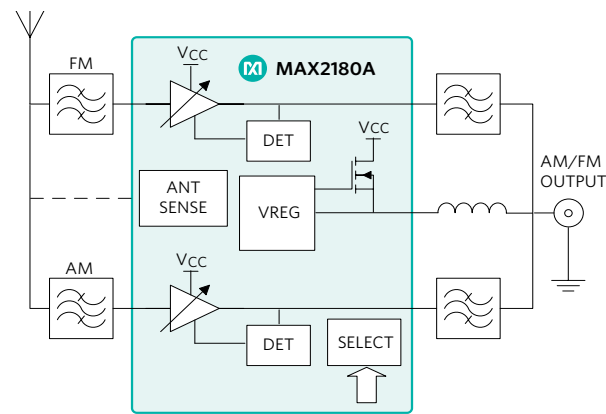

Figure 2. MAX2180A integrated LNA with selectable configurations

The AM and FM signal paths include adjustable maximum gain and AGC thresholds to maximize flexibility and enable seamless interfacing to downstream tuners. These gain values and the AGC attack points are selected via external pins, enabling rapid

implementation of different configurations within the same PC board (Figure 2).

In addition, MAX2180A supports operation down to 6V (Figure 3). This makes it ideal for use in vehicles employing start/stop technology which experience large voltage dips when the engine is starting. Historically, voltage dips have been a minor consideration because once the car started the electrical system maintained a relatively constant 14V supply. With the new start/stop technology the engine is automatically shut off when the car is not moving. The engine must be frequently restarted, and the radio must maintain functionality throughout the repeated restarts and corresponding dips in device supply voltage.

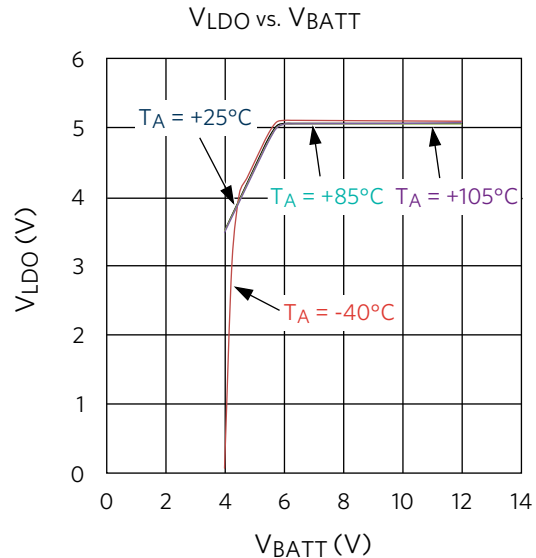

Figure 3. MAX2180A low battery operation

Conclusion

The challenges of rapid implementation of active antennas in automotive applications, in the face of ever shrinking footprint and diverse requirements, were highlighted. An ideal solution was presented which meets these challenges by integrating all active and several passive components into the solution. The solution has added flexibility in the form of selection pins that set the main internal parameters, and in an operating voltage that supports vehicles employing the new start/stop technology.

Learn more: [MAX2180A AM/FM Car Antenna Low-Noise Amplifier](#)

Design Solutions No. 3

Need Design Support?
Call 888 MAXIM-IC (888 629-4642)

Maxim Integrated
160 Rio Robles
San Jose, CA 95134 USA
408-601-1000
maximintegrated.com

