

Customer Information Sheet

DRAWING No.: G125-MS1XX05L2R

IF IN DOUBT - ASK

©

NOT TO SCALE

THIRD ANGLE PROJECTION

ALL DIMENSIONS IN mm

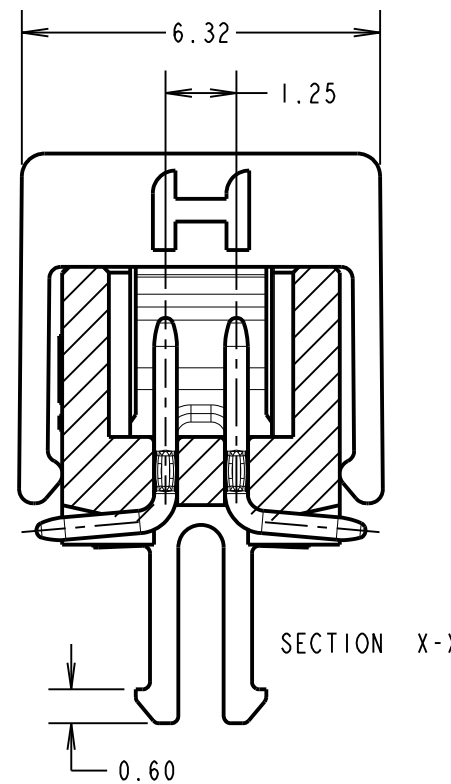
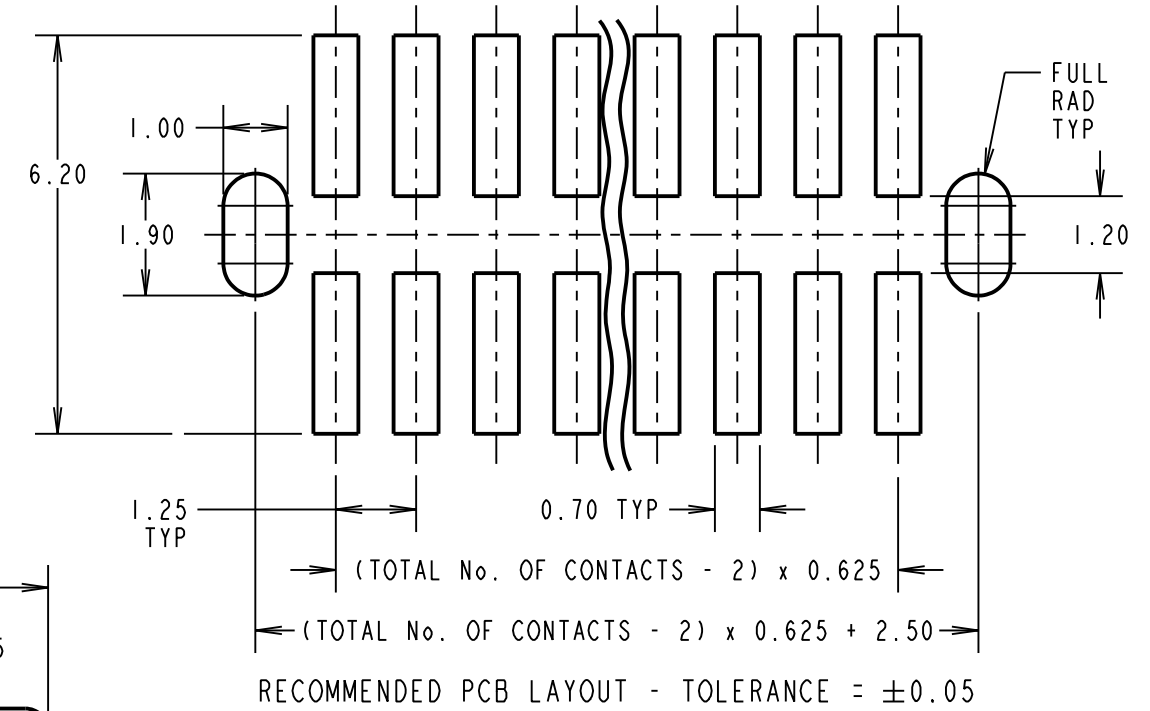
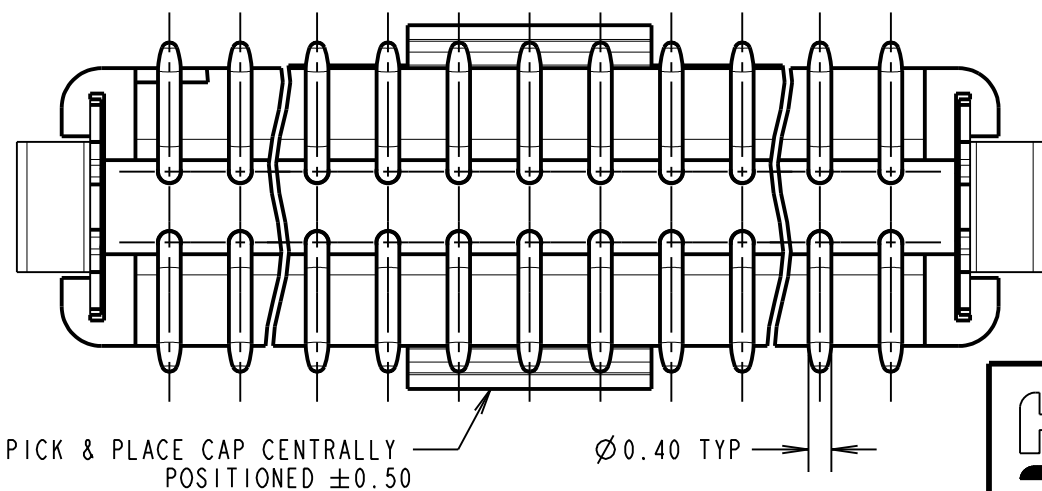
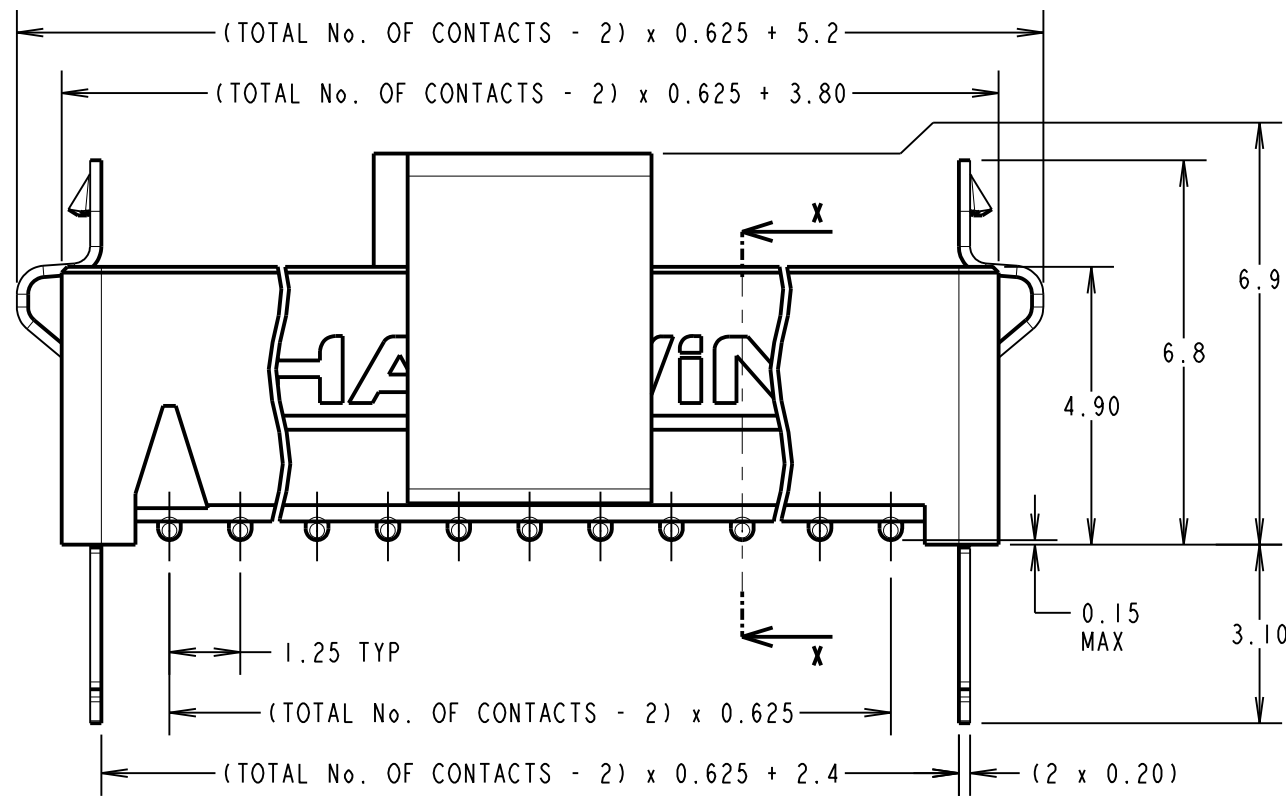
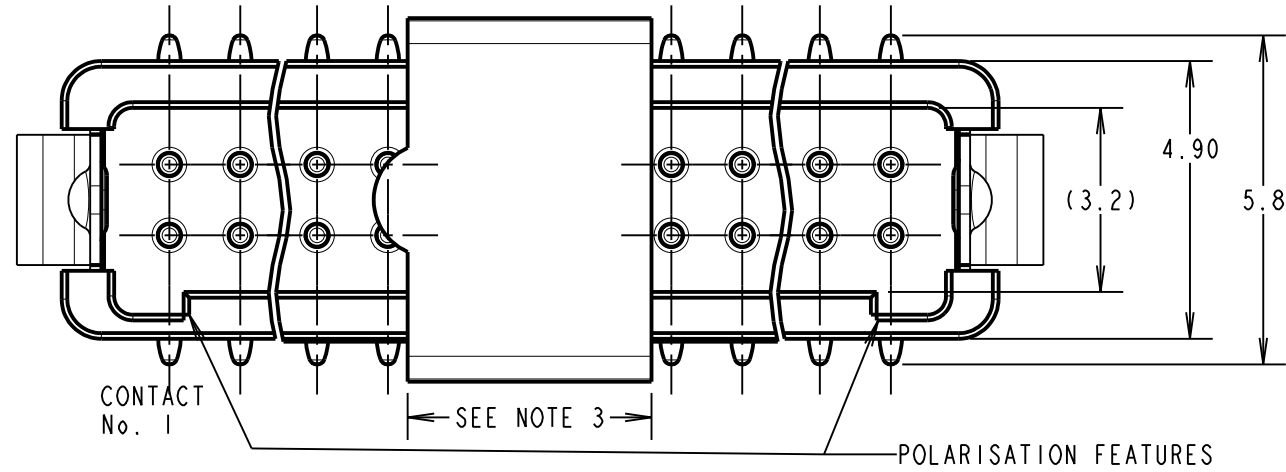

ORDER CODE: **G125-MS1XX05L2R**
 TOTAL No. OF CONTACTS:
 06, 10, 12, 16, 20, 26, 34, 50

CONNECTOR DETAILS AND PCB LAYOUT ONLY. SEE SHEET 5 FOR TAPE AND REEL DETAILS.

NOTES:

- FOR COMPLETE SPECIFICATION, SEE COMPONENT SPECIFICATION C125XX (LATEST ISSUE).
- CO-PLANARITY OF SMT TAILS NOT TO EXCEED 0.10mm. RECOMMENDED SOLDER PASTE THICKNESS = 0.125mm MIN.
- PICK AND PLACE CAP LENGTH = 4.3mm ON ALL PART NUMBERS EXCEPT G125-MS10605L2R ON THIS PART LENGTH = 3.3mm.

MR	7	27.06.22	31567
NAME	ISS.	DATE	CN/CO
APPROVED:		M. RUDKIN	
CHECKED:		R. PORTLOCK	
DRAWN:		S. FLOWER	
CUSTOMER REF.:			
ASSEMBLY DRG:			

HARWIN

www.harwin.com
technical@harwin.com

THIS DRAWING AND ANY INFORMATION OR DESCRIPTIVE MATTER SET OUT HEREON ARE CONFIDENTIAL AND COPYRIGHT PROPERTY OF THE HARWIN GROUP AND MUST NOT BE DISCLOSED, LOANED, COPIED OR USED FOR MANUFACTURING, TENDERING OR FOR ANY OTHER PURPOSE WITHOUT THEIR WRITTEN PERMISSION.

TOLERANCES

X. = ±1mm
 X.X = ±0.50mm
 X.XX = ±0.20mm
 X.XXX = ±0.01mm
 ANGLES = ±5°
 UNLESS STATED

MATERIAL:

SEE SPECIFICATION SHEET

FINISH: SEE SPECIFICATION SHEET

S/AREA: mm²

TITLE:

1.25mm GECKO MALE VERTICAL SMT CONNECTORS IN TAPE & REEL

DRAWING NUMBER:

G125-MS1XX05L2R

SHT
4
OF
5

Customer Information Sheet

DRAWING No.: G125-MS1XX05L2R

IF IN DOUBT - ASK

©

NOT TO SCALE

THIRD ANGLE PROJECTION

ALL DIMENSIONS IN mm

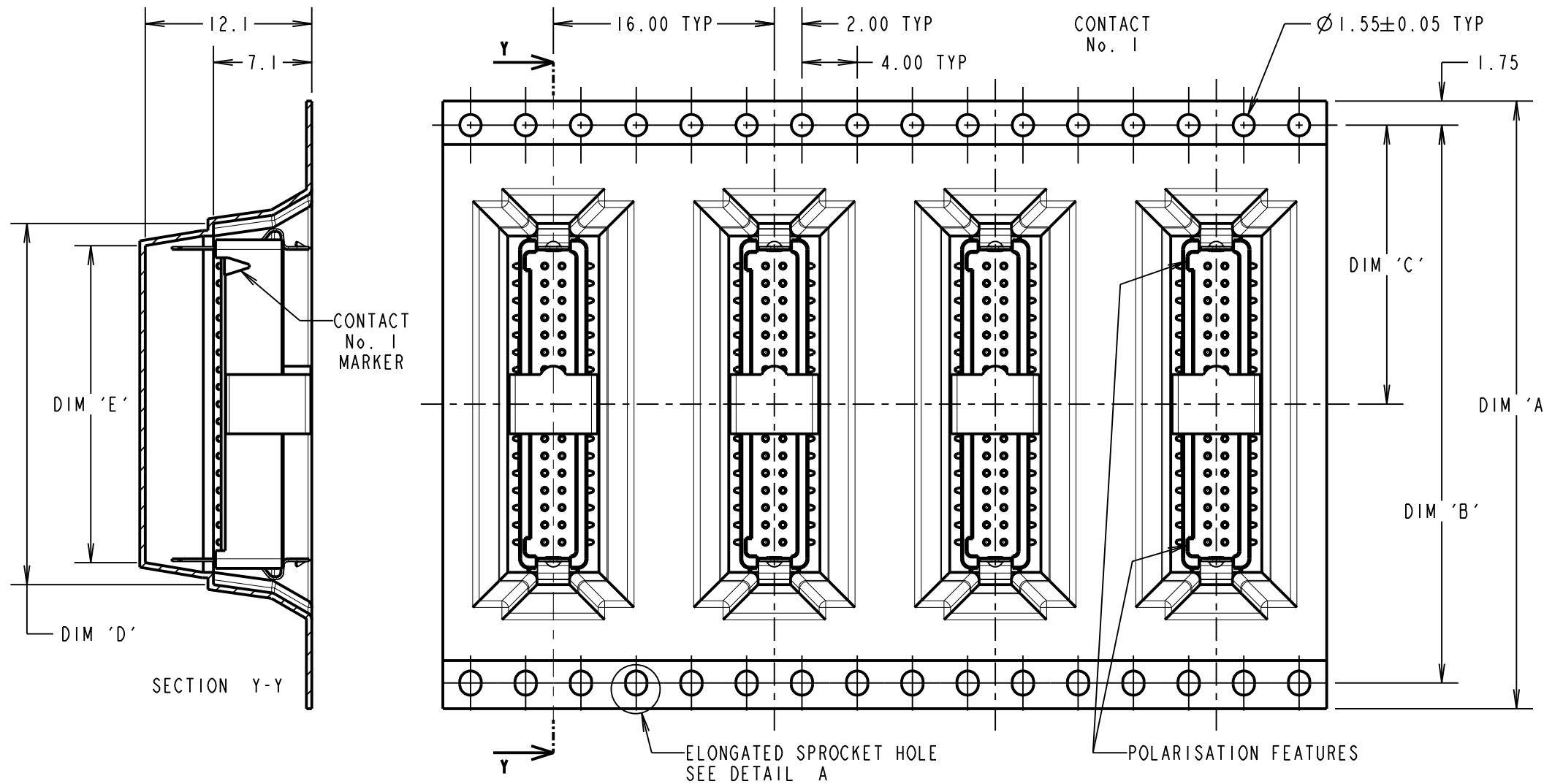

ORDER CODE: **G125-MS1XX05L2R**
 TOTAL No. OF CONTACTS: 06, 10, 12, 16, 20, 26, 34, 50

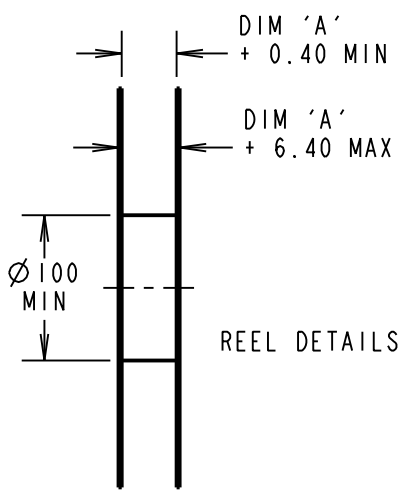
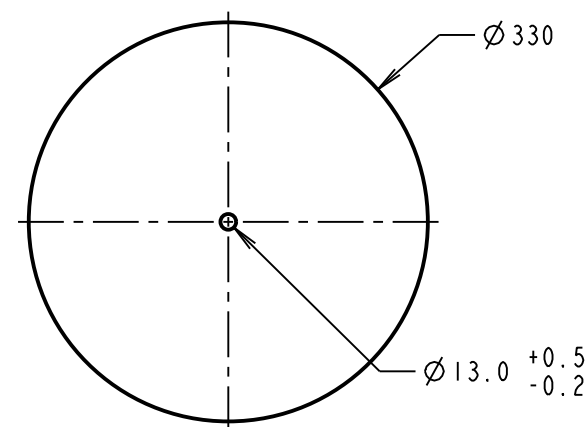
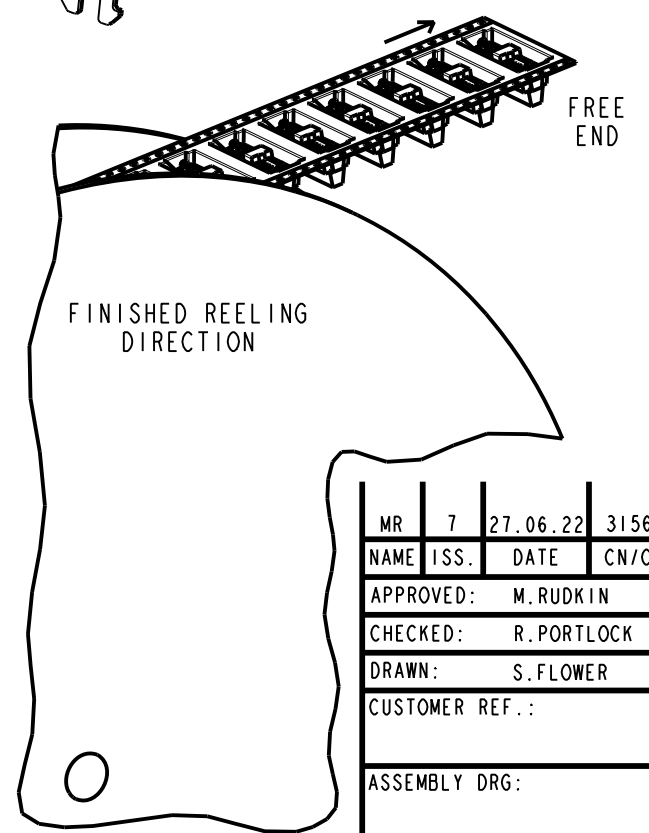
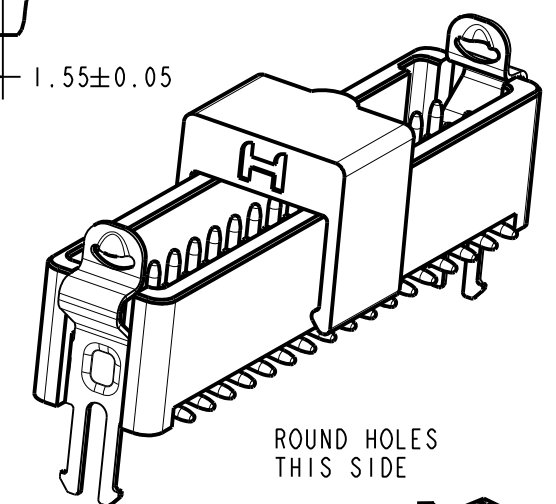
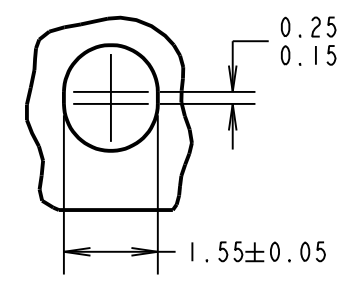

PART No.	DIM 'A'	DIM 'B'	DIM 'C'	DIM 'D'	DIM 'E'
G125-MS10605L2R	24.0±0.3	NO ELONGATED HOLE	11.50	(8.7)	(5.5)
G125-MS11005L2R				(11.2)	(8.0)
G125-MS11205L2R	32.0±0.3	28.40	14.20	(12.4)	(9.2)
G125-MS11605L2R				(14.9)	(11.7)
G125-MS12005L2R	44.0±0.3	40.40	20.2±0.15	(17.4)	(14.2)
G125-MS12605L2R				(21.2)	(18.0)
G125-MS13405L2R				(26.2)	(23.0)
G125-MS15005L2R	56.0±0.3	52.40	26.2±0.15	(36.2)	(33.0)

- NOTES:
1. QUANTITY OF COMPONENTS PER REEL = 250.
 2. FOR OTHER QUANTITIES SEE G125-MS1XX05L2P.
 3. THIS PRODUCT IS TAPED AND REELED IN ACCORDANCE WITH EIA-481-2-A (ELECTRONIC INDUSTRIES ASSOCIATION).
 4. COMPONENTS ARE ORIENTATED IN TAPE POCKETS SO THAT THE POLARISING FEATURES ARE FACING AWAY FROM THE FREE END.
 5. ELONGATED SPROCKET HOLE NOT PRESENT ON 06 & 10 POSITIONS.

HARWIN
 www.harwin.com
 technical@harwin.com

THIS DRAWING AND ANY INFORMATION OR DESCRIPTIVE MATTER SET OUT HEREON ARE CONFIDENTIAL AND COPYRIGHT PROPERTY OF THE HARWIN GROUP AND MUST NOT BE DISCLOSED, LOANED, COPIED OR USED FOR MANUFACTURING, TENDERING OR FOR ANY OTHER PURPOSE WITHOUT THEIR WRITTEN PERMISSION.

TOLERANCES
 X. = ±1mm
 X.X = ±0.50mm
 X.XX = ±0.20mm
 X.XXX = ±0.01mm
 ANGLES = ±5°
 UNLESS STATED

MATERIAL:
 SEE SPECIFICATION SHEET
 FINISH: SEE SPECIFICATION SHEET
 S/AREA: mm²

TITLE:
 1.25mm GECKO MALE VERTICAL SMT CONNECTORS IN TAPE & REEL
 DRAWING NUMBER:
G125-MS1XX05L2R
 SHT 5 OF 5

MR	7	27.06.22	31567
NAME	ISS.	DATE	CN/CO
APPROVED:		M. RUDKIN	
CHECKED:		R. PORTLOCK	
DRAWN:		S. FLOWER	
CUSTOMER REF.:			
ASSEMBLY DRG:			