

# Customer Information Sheet

DRAWING No.: M58-280XX42R

IF IN DOUBT - ASK

©

NOT TO SCALE

THIRD ANGLE PROJECTION

ALL DIMENSIONS IN mm

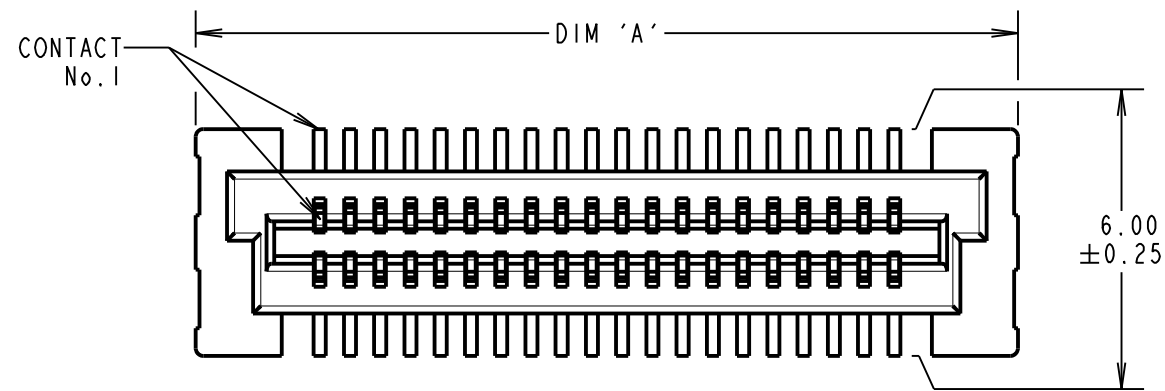

NOTES:

- FOR COMPLETE SPECIFICATION SEE COMPONENT SPECIFICATION C053XX (LATEST ISSUE).
- SEE SHEET 5 FOR TAPE AND REEL DETAILS.
- DRAWING SHOWS M58-2800442R.
- PCB LAYOUT SHOWING FOOTPRINT OF M58-2800642R.

MATED VIEW FOR STACK HEIGHT WHEN MATED WITH M58-380XX42R

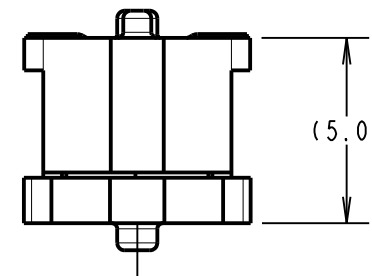
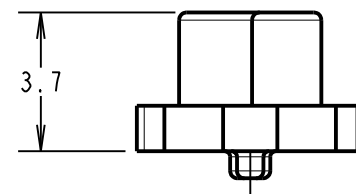
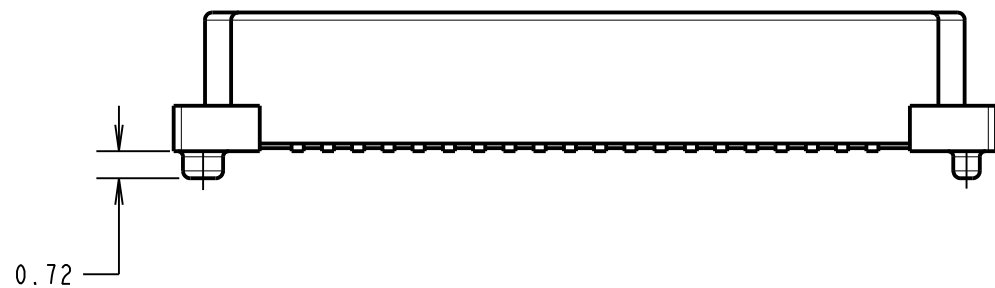

PART No.	DIMENSION			WEIGHT (g)
	DIM 'A'	DIM 'B'	DIM 'C'	
M58-2800342R	17.75	16.20	11.20	0.36
M58-2800442R	21.75	20.20	15.20	0.45
M58-2800642R	29.75	28.20	23.20	0.62
M58-2800842R	37.75	36.20	31.20	0.79
M58-2801042R	45.75	44.20	39.20	0.97
M58-2801242R	53.75	52.20	47.20	1.14

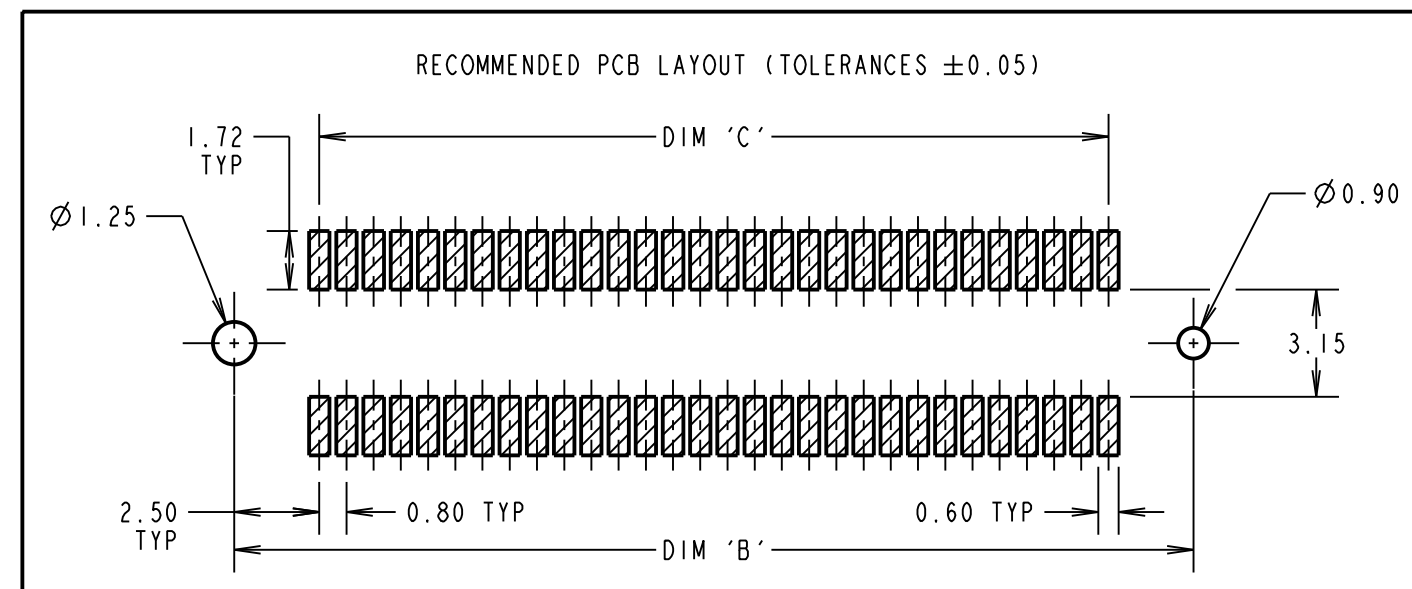
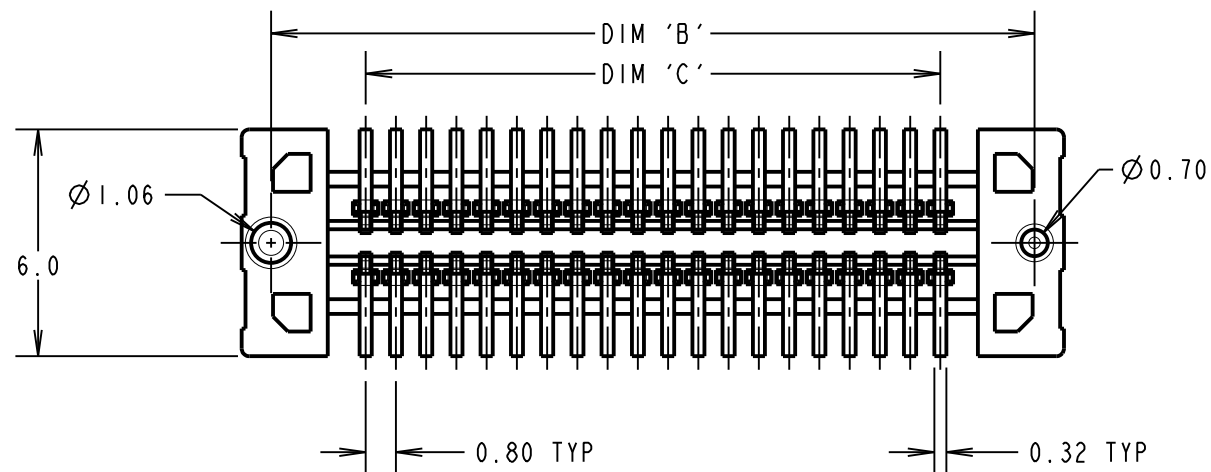

ORDER CODE:

**M58-280XX42R**

No. OF CONTACTS:	
03 = 30 CONTACTS (15+15)	08 = 80 CONTACTS (40+40)
04 = 40 CONTACTS (20+20)	10 = 100 CONTACTS (50+50)
06 = 60 CONTACTS (30+30)	12 = 120 CONTACTS (60+60)

**HARWIN**

www.harwin.com  
technical@harwin.com

THIS DRAWING AND ANY INFORMATION OR DESCRIPTIVE MATTER SET OUT HEREON ARE CONFIDENTIAL AND COPYRIGHT PROPERTY OF THE HARWIN GROUP AND MUST NOT BE DISCLOSED, LOANED, COPIED OR USED FOR MANUFACTURING, TENDERING OR FOR ANY OTHER PURPOSE WITHOUT THEIR WRITTEN PERMISSION.

TOLERANCES

X. = ±1mm  
X.X = ±0.50mm  
X.XX = ±0.20mm  
X.XXX = ±0.01mm  
ANGLES = ±5°  
UNLESS STATED

MATERIAL:

SEE ABOVE

FINISH:

SEE ABOVE

S/AREA:

mm<sup>2</sup>

TITLE:

FEMALE 0.8mm PITCH BOARD TO BOARD VERTICAL SMT

DRAWING NUMBER:

**M58-280XX42R**

RA	2	28.10.21	31179
NAME	ISS.	DATE	CN/CO
APPROVED: R.ALEXANDER			
CHECKED: R.PORTLOCK			
DRAWN: R.ALEXANDER			
CUSTOMER REF.:			
ASSEMBLY DRG:			

# Customer Information Sheet

DRAWING No.:

IF IN DOUBT - ASK

©

NOT TO SCALE

THIRD ANGLE PROJECTION

ALL DIMENSIONS IN mm

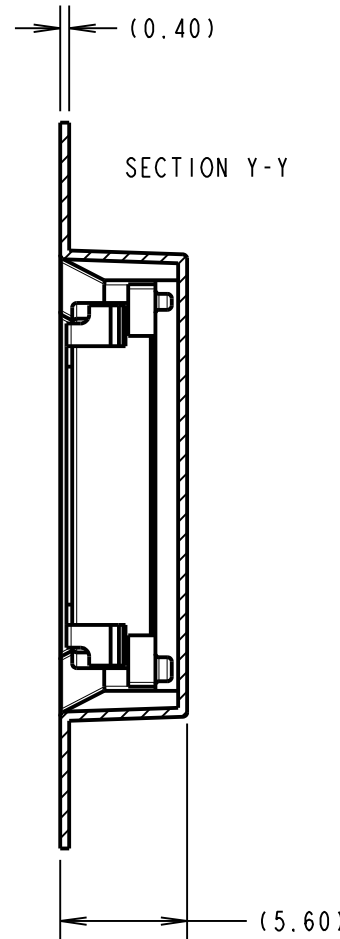
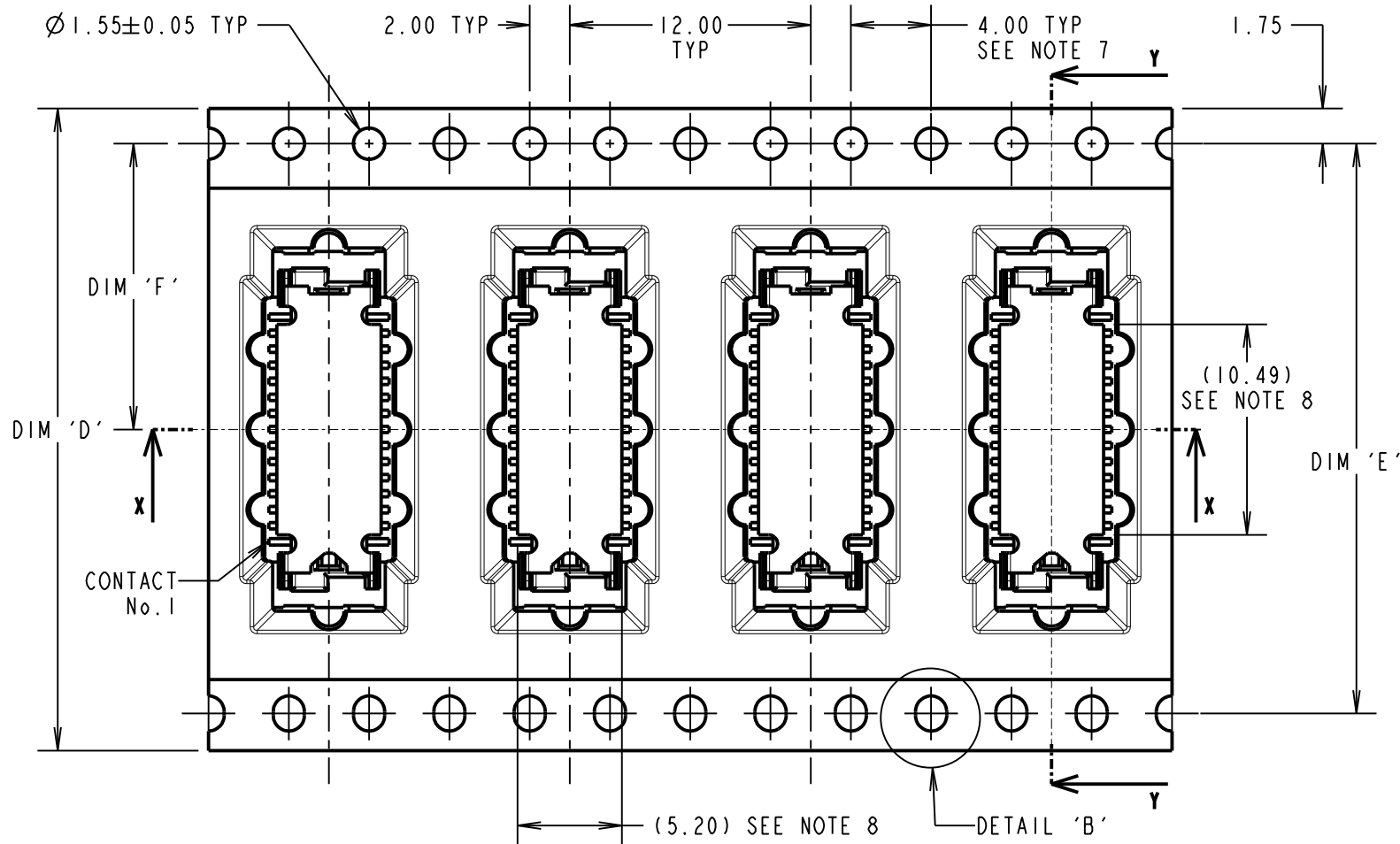

- NOTES:
5. TAPE AND REEL DRAWING SHOWS M58-2800442R.
  6. THIS PRODUCT IS TAPED AND REELED IN GENERAL ACCORDANCE WITH EIA-418 (ELECTRONICS INDUSTRY ASSOCIATION).
  7. CUMULATIVE TOLERANCE OVER 10 PITCHES =  $\pm 0.20\text{mm}$ .
  8. PICK AND PLACE CAP DIMENSIONS.

PART No.	DIMENSION			PCS/REEL
	DIM 'D' $\pm 0.30$	DIM 'E'	DIM 'F'	
M58-2800342R	32.00	28.40	14.20	800
M58-2800442R	44.00	40.40	20.20	800
M58-2800642R	56.00	52.40	26.20	800
M58-2800842R	56.00	52.40	26.20	800
M58-2801042R	72.00	68.40	34.20	800
M58-2801242R	72.00	68.40	34.20	800

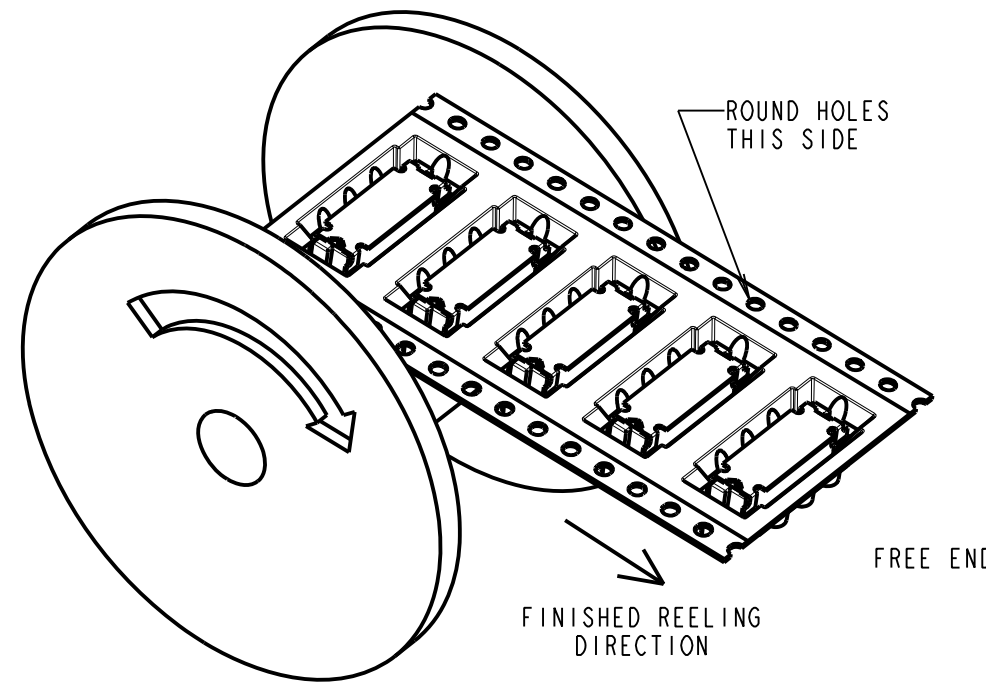
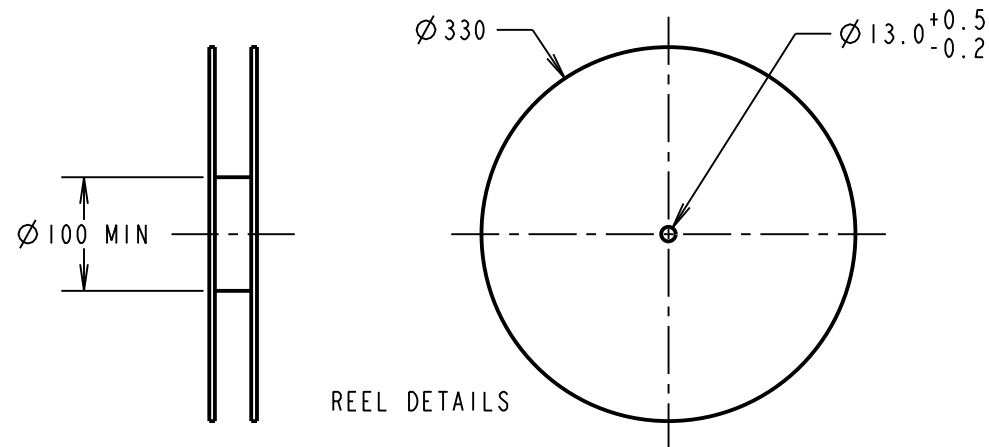
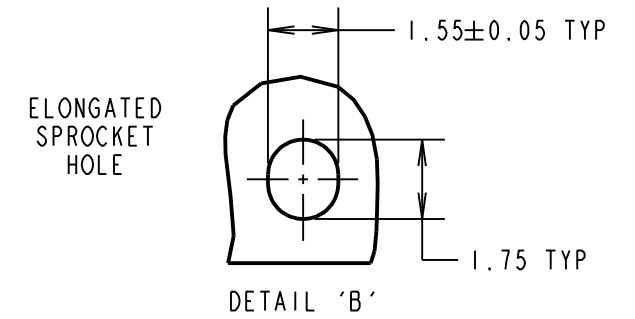
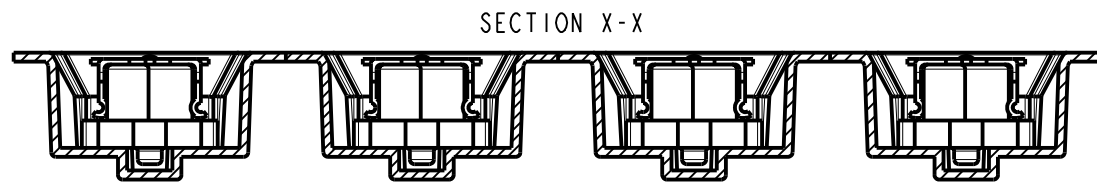

RA	2	28.10.21	31179
NAME	ISS.	DATE	CN/CO
APPROVED: R.ALEXANDER			
CHECKED: R.PORTLOCK			
DRAWN: R.ALEXANDER			
CUSTOMER REF.:			
ASSEMBLY DRG:			

ORDER CODE:

**M58-280XX42R**

No. OF CONTACTS:	
03 = 30 CONTACTS (15+15)	08 = 80 CONTACTS (40+40)
04 = 40 CONTACTS (20+20)	10 = 100 CONTACTS (50+50)
06 = 60 CONTACTS (30+30)	12 = 120 CONTACTS (60+60)

**HARWIN**

www.harwin.com  
technical@harwin.com

THIS DRAWING AND ANY INFORMATION OR DESCRIPTIVE MATTER SET OUT HEREON ARE CONFIDENTIAL AND COPYRIGHT PROPERTY OF THE HARWIN GROUP AND MUST NOT BE DISCLOSED, LOANED, COPIED OR USED FOR MANUFACTURING, TENDERING OR FOR ANY OTHER PURPOSE WITHOUT THEIR WRITTEN PERMISSION.

TOLERANCES

X. =  $\pm 1\text{mm}$   
X.X =  $\pm 0.50\text{mm}$   
X.XX =  $\pm 0.20\text{mm}$   
X.XXX =  $\pm 0.01\text{mm}$   
ANGLES =  $\pm 5^\circ$   
UNLESS STATED

MATERIAL:

SEE ABOVE

FINISH:

SEE ABOVE

S/AREA:

mm<sup>2</sup>

TITLE:

FEMALE 0.8mm PITCH BOARD TO BOARD VERTICAL SMT

DRAWING NUMBER:

**M58-280XX42R**

SHT  
5 OF 5