

XC9263/XC9264 Series

ETR05047-007

18V Operation 0.5A Synchronous Step-Down DC/DC Converters

■ GENERAL DESCRIPTION

The XC9263/XC9264 series are 18V operation synchronous step-down DC/DC converter ICs with a built-in high-side / low-side driver transistor. The XC9263/XC9264 series has operating voltage range of 3.0V~18.0V and it can support 500mA as an output current with high-efficiency. Compatible with Low ESR capacitors such as ceramic capacitors for the load capacitor (C_L).

0.75V reference voltage source is incorporated in the IC, and the output voltage can be set to a value from 1.0V to 15.0V using external resistors (R_{FB1}, R_{FB2}).

500kHz or 1.2MHz or 2.2MHz can be selected for the switching frequency. In PWM/PFM automatic switchover control, IC can change the control method between PWM and PFM based on the output current requirement and as a result IC can achieve high efficiency over the full load range.

XC9263/64 has a fixed internal soft start time which is 1.0ms (TYP.), additionally the time can be extended by using an external resistor and capacitor.

With the built-in UVLO function, the driver transistor is forced OFF when input voltage goes down to 2.7V or lower. The output state can be monitored using the power good function.

Over current protection and thermal shutdown are embedded and they secure a safety operation.

■ APPLICATIONS

- Hot water supply system
- Recorders, Camcorders
- Refrigerators, Air-conditioners
- Low Power Systems

■ FEATURES

Input Voltage Range	:	3.0 ~ 18V (Absolute Max 20V)
FB Voltage	:	0.75V±1.5%
Oscillation Frequency	:	500kHz, 1.2MHz, 2.2MHz
Output Current	:	500mA
Control Methods	:	PWM/PFM Auto
		Efficiency 85%@12V→5V, 1mA
		PWM control
Soft-start Time	:	Adjustable by RC
Protection Circuits	:	Over Current Protection
		Automatic Recovery (B Type)
		Integral Latch Method (A Type)
		Thermal Shutdown
Output Capacitor	:	Ceramic Capacitor
Package	:	SOT-25 (No Power good)
		USP-6C (With Power Good)
Environmentally Friendly	:	EU RoHS Compliant, Pb Free

■ TYPICAL APPLICATION CIRCUIT

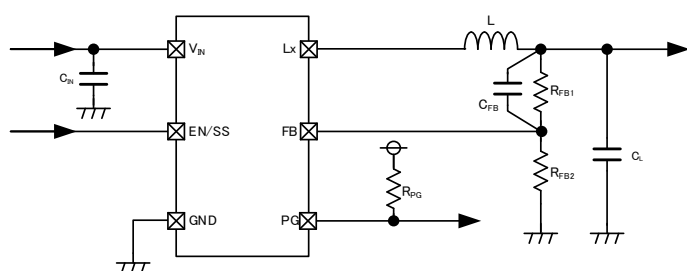

■ TYPICAL PERFORMANCE CHARACTERISTICS

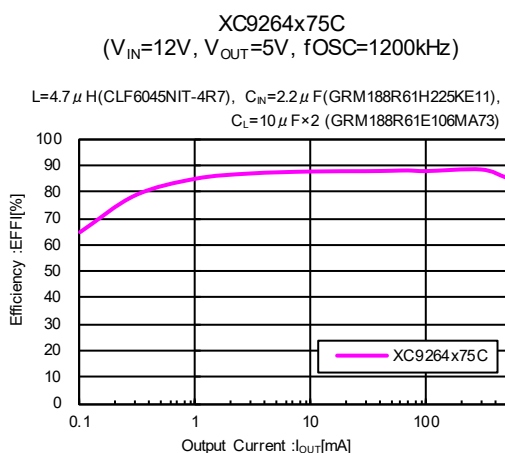

■ BLOCK DIAGRAM

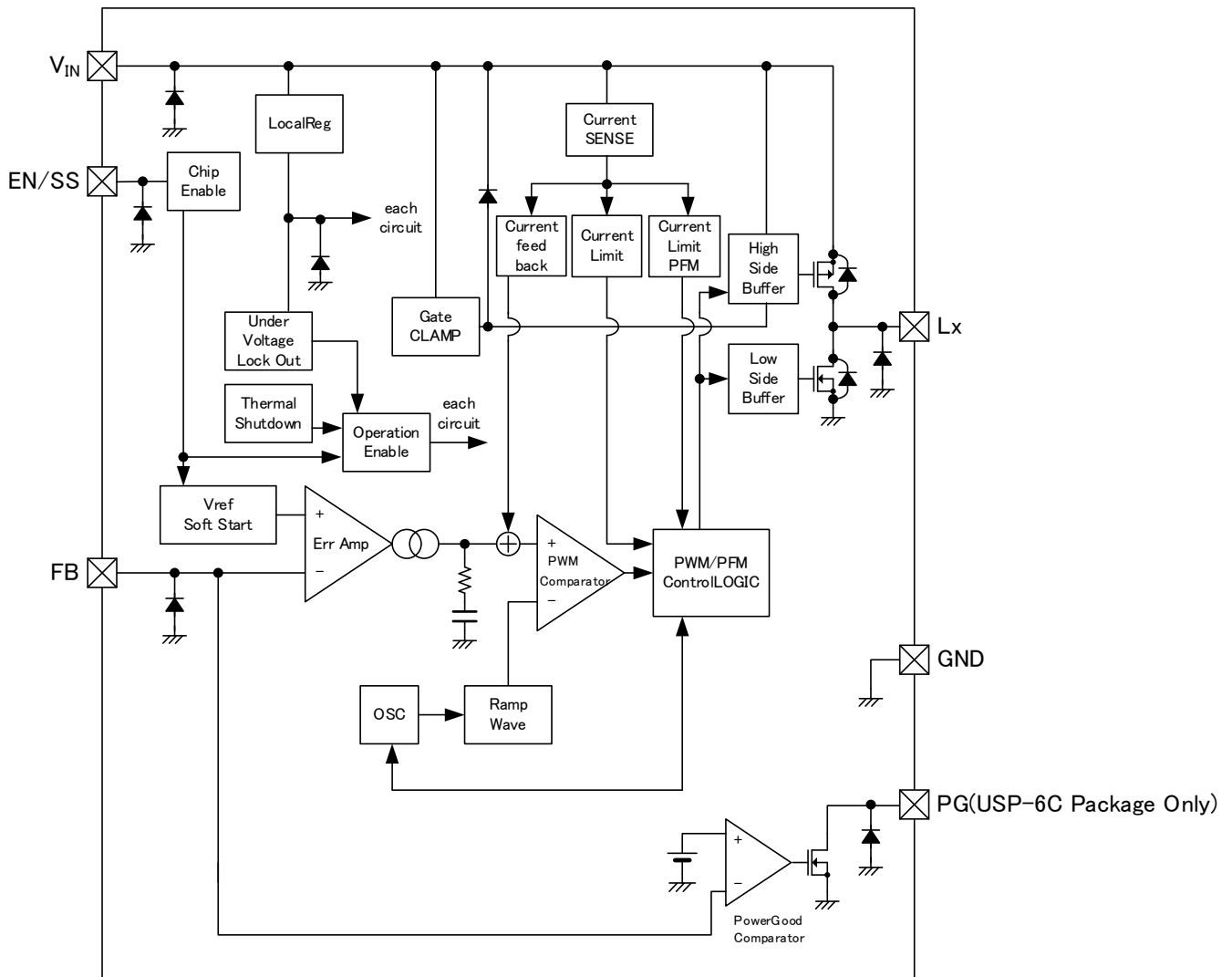

*Diodes inside the circuit are an ESD protection diodes and a parasitic diodes.

■ PRODUCT CLASSIFICATION

● Ordering Information

XC9263①②③④⑤⑥-⑦^(*) PWM control

XC9264①②③④⑤⑥-⑦^(*) PWM/PFM Auto

DESIGNATOR	ITEM	SYMBOL	DESCRIPTION
①	Type	A	Refer to Selection Guide
		B	
②③	FB Voltage	75	Output voltage can be adjusted in 1V to 15V
④	Oscillation Frequency	5	500kHz
		C	1.2MHz
		D	2.2MHz
⑤⑥-⑦	Packages (Order Unit)	MR-G ^(*)	SOT-25 (3,000pcs/Reel)
		ER-G ^(*)	USP-6C (3,000pcs/Reel)

^(*) The "-G" suffix denotes Halogen and Antimony free as well as being fully EU RoHS compliant.

● Selection Guide

FUNCTION	A TYPE		B TYPE	
	SOT-25	USP-6C	SOT-25	USP-6C
Chip Enable	Yes	Yes	Yes	Yes
UVLO	Yes	Yes	Yes	Yes
Thermal Shutdown	Yes	Yes	Yes	Yes
Soft Start	Yes	Yes	Yes	Yes
Power-Good	-	Yes	-	Yes
Current Limiter (Automatic Recovery)	-	-	Yes	Yes
Current Limiter (Latch Protection ⁽²⁾)	Yes	Yes	-	-

⁽²⁾ The over-current protection latch is an integral latch type.

■ PIN CONFIGURATION

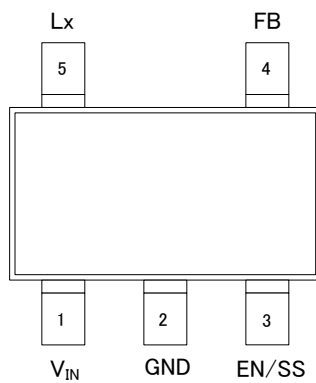

**SOT-25
(TOP VIEW)**

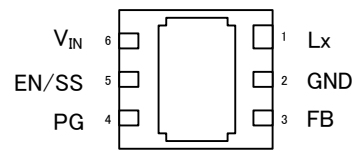

**USP-6C
(BOTTOM VIEW)**

* The dissipation pad for the USP-6C package should be solder-plated in recommended mount pattern and metal masking so as to enhance mounting strength and heat release. If the pad needs to be connected to other pins, it should be connected to the GND (No. 2) pin.

■ PIN ASSIGNMENT

PIN NUMBER		PIN NAME	FUNCTION
SOT-25	USP-6C		
1	6	V _{IN}	Power Input
3	5	EN/SS	Enable Soft-start
-	4	PG	Power good Output
4	3	FB	Output Voltage Sense
2	2	GND	Ground
5	1	Lx	Switching Output

FUNCTION CHART

PIN NAME	SIGNAL	STATUS
EN/SS	L	Stand-by
	H	Active
	OPEN	Undefined State ^(*)

^(*) Please do not leave the EN/SS pin open. Each should have a certain voltage.

PIN NAME	CONDITION	SIGNAL	
PG	EN/SS = H	$V_{FB} > V_{PGDET}$	H (High impedance)
		$V_{FB} \leq V_{PGDET}$	L (Low impedance)
		Thermal Shutdown	L (Low impedance)
		UVLO ($V_{IN} < V_{UVLO1}$)	Undefined State
	EN/SS = L	Stand-by	L (Low impedance)

ABSOLUTE MAXIMUM RATINGS

PARAMETER	SYMBOL	RATINGS	UNITS
V _{IN} Pin Voltage	V _{IN}	-0.3 ~ 20	V
EN/SS Pin Voltage	V _{EN/SS}	-0.3 ~ 20	V
FB Pin Voltage	V _{FB}	-0.3 ~ 6.2	V
PG Pin Voltage ^(*)	V _{PG}	-0.3 ~ 6.2	V
PG Pin Current ^(*)	I _{PG}	8	mA
Lx Pin Voltage	V _{Lx}	-0.3 ~ V _{IN} + 0.3 or 20 ⁽²⁾	V
Lx Pin Current	I _{Lx}	1800	mA
Power Dissipation (Ta=25°C)	SOT-25	250	mW
		600 (40mm x 40mm Standard board) ⁽³⁾	
	760 (JESD51-7 Board) ⁽³⁾		
	USP-6C	120	
	1000 (40mm x 40mm Standard board) ⁽³⁾		
1250 (JESD51-7 Board) ⁽³⁾			
Operating Ambient Temperature	Topr	-40 ~ 105	°C
Storage Temperature	Tstg	-55 ~ 125	°C

* All voltages are described based on the GND pin.

^(*) For the USP-6C Package only.

⁽²⁾ The maximum value should be either V_{IN}+0.3V or 20V in the lowest.

⁽³⁾ The power dissipation figure shown is PCB mounted and is for reference only.

Please refer to PACKAGING INFORMATION for the mounting condition.

ELECTRICAL CHARACTERISTICS

Ta=25°C

PARAMETER	SYMBOL	CONDITIONS	MIN	TYP	MAX	UNIT	CIRCUIT	
FB Voltage	V _{FB}	V _{FB} =0.739V → 0.761V V _{FB} Voltage when Lx pin oscillates	0.739	0.750	0.761	V	②	
Output Voltage Setting Range ⁽¹⁾	V _{OUTSET}	-	1	-	15	V	-	
Operating Voltage Range	V _{IN}	-	3	-	18	V	-	
UVLO Detect Voltage	V _{UVLO1}	V _{IN} :2.8V→2.6V, V _{FB} =0.675V V _{IN} Voltage when Lx pin voltage changes from "H" level to "L" level	2.60	2.70	2.80	V	②	
UVLO Release Voltage	V _{UVLO2}	V _{IN} :2.7V→2.9V, V _{FB} =0.675V V _{IN} Voltage when Lx pin voltage changes from "L" level to "H" level	2.70	2.80	2.90	V	②	
Quiescent Current	I _q	V _{FB} =0.825V	XC9264x755	-	11.5	16.5	μA	④
			XC9264x75C	-	12.5	17.5	μA	④
			XC9264x75D	-	13.5	18.5	μA	④
Stand-by Current	I _{STB}	V _{EN/SS} =0V	-	1.65	2.5	μA	⑤	
Oscillation Frequency	f _{OSC}	Connected to external components, I _{OUT} =100mA	XC926xx755	458	500	542	kHz	①
			XC926xx75C	1098	1200	1302	kHz	①
			XC926xx75D	2013	2200	2387	kHz	①
Minimum Duty Cycle	D _{MIN}	V _{FB} =0.825V	-	-	0	%	②	
Maximum Duty Cycle	D _{MAX}	V _{FB} =0.675V	100	-	-	%	②	
Lx SW "H" On Resistance	R _{LxH}	V _{FB} =0.675V, I _{Lx} =200mA	USP-6C	-	0.95	1.10	Ω	②
			SOT-25	-	0.99	1.14	Ω	②
Lx SW "L" On Resistance	R _{LxL}	V _{FB} =0.825V, I _{Lx} =200mA	USP-6C	-	0.69 ⁽²⁾	-	Ω	②
			SOT-25	-	0.73 ⁽²⁾	-	Ω	②
PFM Switch Current	I _{PFM}	Connected to external components, I _{OUT} =1mA	XC9264x755	-	380	-	mA	①
			XC9264x75C	-	420	-	mA	
			XC9264x75D	-	370	-	mA	
High-side Current Limit ⁽³⁾	I _{LIMH}	V _{FB} =0.675V	920	1100	-	mA	②	
Latch Time	t _{LAT}	Type A only, Connected to external components, V _{FB} =0V	0.5	1.0	1.7	ms	⑥	
Internal Soft-Start Time	t _{SS1}	V _{EN/SS} =0V→12V, V _{FB} =0.675V Time until Lx pin oscillates	0.5	1.0	1.7	ms	②	
External Soft-Start Time	t _{SS2}	V _{EN/SS} =0V→12V, V _{FB} =0.675V R _{SS} =430KΩ, C _{SS} =0.47 μF Time until Lx pin oscillates	17	26	35	ms	③	
PG Detect Voltage ⁽⁴⁾	V _{PGDET}	V _{FB} =0.712V→0.638V, R _{PG} :100kΩ pull-up to 5V V _{FB} Voltage when PG pin voltage changes from "H" level to "L" level	0.638	0.675	0.712	V	②	
PG Output Voltage ⁽⁴⁾	V _{PG}	V _{FB} =0.6V, I _{PG} =1mA	-	-	0.3	V	②	
Efficiency ⁽⁵⁾	EFFI	Connected to external components, V _{OUT} =5V, I _{OUT} =1mA	-	85	-	%	①	
FB Voltage Temperature Characteristics	ΔV _{FB} / (ΔT _{opr} ·V _{FB})	-40°C ≤ Ta ≤ 105°C	-	±100	-	ppm/°C	②	

Test Condition: Unless otherwise stated, V_{IN}=12V, V_{EN/SS}=12V

⁽¹⁾: Please use within the range of V_{OUT}/V_{IN} ≥ 0.12 (f_{osc}=500kHz), V_{OUT}/V_{IN} ≥ 0.14 (f_{osc}=1.2MHz), V_{OUT}/V_{IN} ≥ 0.17 (f_{osc}=2.2MHz)

⁽²⁾: Design reference value. This parameter is provided only for reference.

⁽³⁾: Current limit denotes the level of detection at peak of coil current.

⁽⁴⁾: For the USP-6C Package only.

⁽⁵⁾: EFFI = {(output voltage) x (output current)} / {(input voltage) x (input current)} x 100

■ ELECTRICAL CHARACTERISTICS (Continued)

Ta=25°C

PARAMETER	SYMBOL	CONDITIONS	MIN	TYP	MAX	UNIT	CIRCUIT
FB 'H' Current	I _{FBH}	V _{IN} =V _{EN/SS} =18V, V _{FB} =3.0V	-0.1	-	0.1	μA	④
FB 'L' Current	I _{FBL}	V _{IN} =V _{EN/SS} =18V, V _{FB} =0V	-0.1	-	0.1	μA	④
EN/SS 'H' Current	I _{EN/SSH}	V _{IN} =V _{EN/SS} =18V, V _{FB} =0.825V	-	0.1	0.3	μA	④
EN/SS 'L' Current	I _{EN/SSL}	V _{IN} =18V, V _{EN/SS} =0V, V _{FB} =0.825V	-0.1	-	0.1	μA	④
EN/SS 'H' Voltage	V _{EN/SSH}	V _{EN/SS} =0.3V→2.5V, V _{FB} =0.71V V _{EN/SS} Voltage when Lx pin voltage changes from "L" level to "H"	2.5	-	18	V	②
EN/SS 'L' Voltage	V _{EN/SSL}	V _{EN/SS} =2.5V→0.3V, V _{FB} =0.71V V _{EN/SS} Voltage when Lx pin voltage changes from "H" level to "L"	-	-	0.3	V	②
Thermal Shutdown Temperature	T _{TSD}	Junction Temperature	-	150	-	°C	-
Hysteresis Width	T _{HYS}	Junction Temperature	-	25	-	°C	-

Test Condition: Unless otherwise stated, V_{IN}=12V, V_{EN/SS}=12V

TEST CIRCUITS

CIRCUIT①

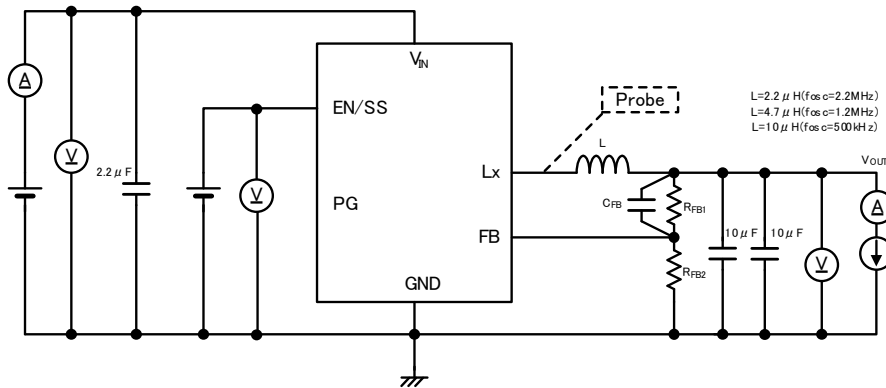

CIRCUIT②

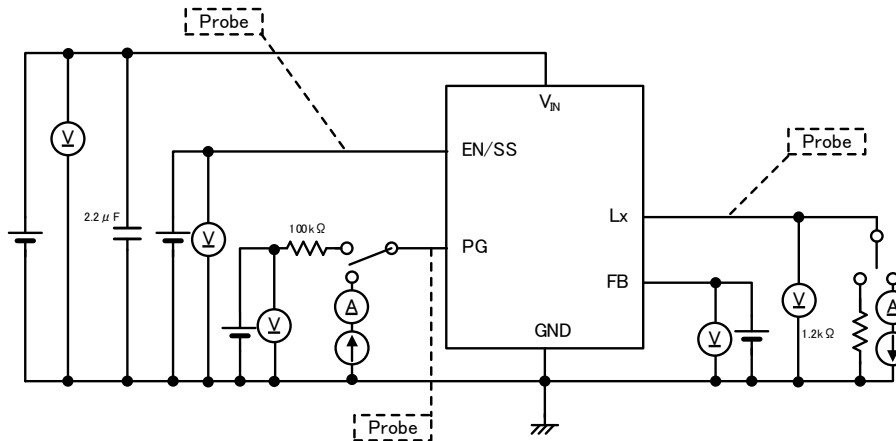

CIRCUIT③

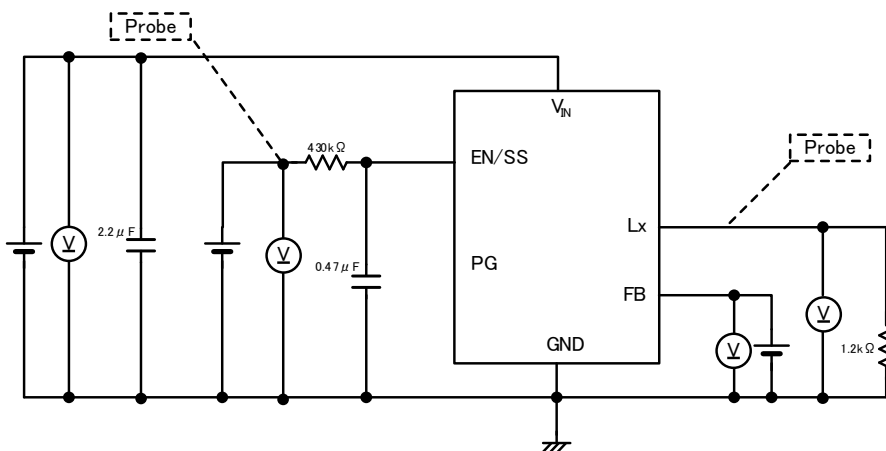

* PG Pin is USP-6C Package only.

■ TEST CIRCUITS (Continued)

CIRCUIT④

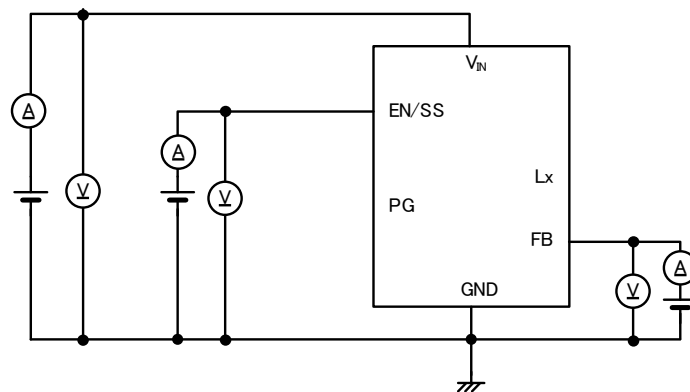

CIRCUIT⑤

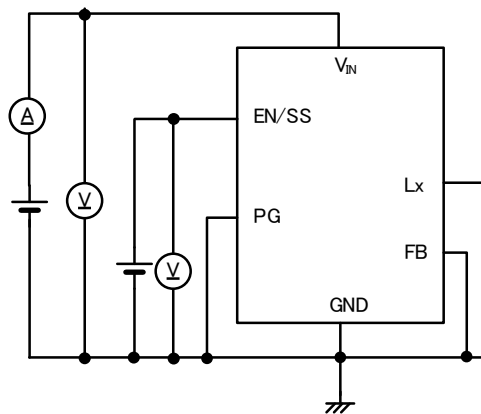

CIRCUIT⑥

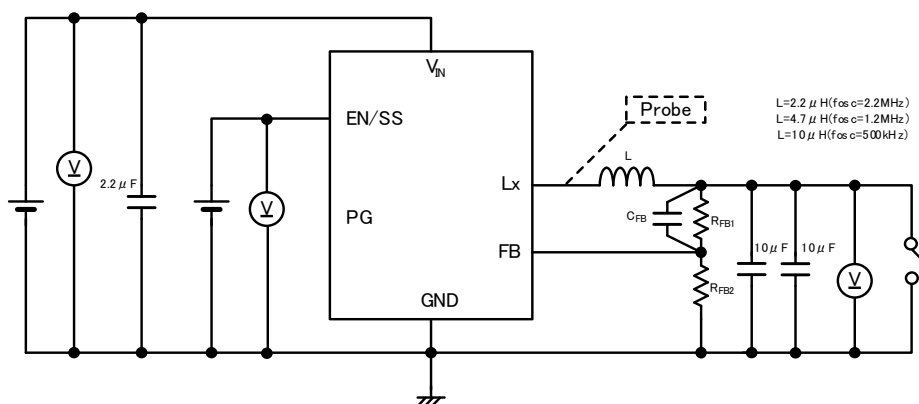

* PG Pin is USP-6C Package only.

TYPICAL APPLICATION CIRCUIT / Parts Selection Method

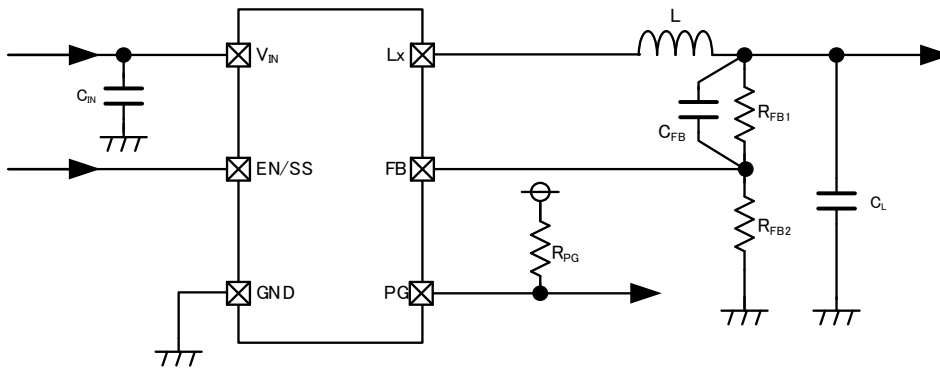

【Typical Examples】

	Oscillation Frequency	MANUFACTURER	PRODUCT NUMBER	VALUE
L	500kHz	TDK	CLF6045NIT-100M	10μH
		Taiyo Yuden	NRS5040T100MMGJ	
		Tokyo Coil	SHP0530P-F100AP	
	1.2MHz	TDK	CLF6045NIT-4R7N	4.7μH
		TDK	VLS252012CX-4R7M-1	
		Taiyo Yuden	NRS5024T4R7MMGJ	
	2.2MHz	Tokyo Coil	SHP0530P-F4R7AP	2.2μH
		TDK	CLF6045NIT-2R2N	
		TDK	VLS252012CX-2R2M-1	
Taiyo Yuden		NRS4018T2R2MDGJ		
Tokyo Coil	SHP0420P-F2R2NAP			
C _{IN}	500kHz, 1.2MHz, 2.2MHz	Murata	GRM188R61H225KE11	2.2μF / 50V
C _L	500kHz	Murata	GRM21BZ71E106KE15	10μF / 25V 2parallel
	1.2MHz, 2.2MHz	Murata	GRM188R61E106MA73	10μF / 25V 2parallel

<Output voltage setting>

The output voltage can be set by adding an external dividing resistor.
The output voltage is determined by the equation below based on the values of R_{FB1} and R_{FB2}.

$$V_{OUT} = V_{FB} \times (R_{FB1} + R_{FB2}) / R_{FB2}$$

With $R_{FB1} + R_{FB2} \leq 1M\Omega$

<C_{FB} setting>

Adjust the value of the phase compensation speed-up capacitor C_{FB} using the equation below.

$$C_{FB} = \frac{1}{2\pi \times f_{zfb} \times R_{FB1}}$$

* When f_{osc}=500kHz or 1.2MHz, a target value for f_{zfb} of about $\frac{1}{2\pi \sqrt{C_L \times L}}$ is optimum.

* When f_{osc}=2.2MHz, a target value for f_{zfb} of about 5kHz is optimum.

【Setting Example】

To set output voltage to 5V with f_{osc}=500kHz, C_L=20μF, L=10μH

When R_{FB1}=680kΩ, R_{FB2}=120kΩ, V_{OUT}=0.75V×(680kΩ+120kΩ) / 120kΩ=5.0V
And f_{zfb} is set to a target of 11.25kHz using the above equation,
C_{FB}=1/(2×π×11.25kHz×680kΩ)=20.8pF

* The setting range for the output voltage is 1.0V to 15.0V.

The condition V_{OUT}/V_{IN} ≥ 0.12 (f_{osc}=500kHz), V_{OUT}/V_{IN} ≥ 0.14 (f_{osc}=1.2MHz), V_{OUT}/V_{IN} ≥ 0.17 (f_{osc}=2.2MHz) must be satisfied.

■ TYPICAL APPLICATION CIRCUIT / Parts Selection Method (Continued)

<Soft-start Time Setting>

The soft-start time can be adjusted by adding a capacitor and a resistor to the EN/SS pin.
Soft-start time (t_{ss2}) is approximated by the equation below according to values of $V_{EN/SS}$, R_{SS} , and C_{SS} .

$$t_{ss2} = C_{SS} \times R_{SS} \times (-\ln((V_{EN/SS} - 1.45) / V_{EN/SS}))$$

【Setting Example】

When $C_{SS} = 0.47\mu\text{F}$, $R_{SS} = 430\text{k}\Omega$ and $V_{EN/SS} = 12\text{V}$, $t_{ss2} = 0.47 \times 10^{-6} \times 430 \times 10^3 \times (-\ln((12 - 1.45) / 12)) = 26\text{ms}$ (Approx.)

*The soft-start time is the time from the start of $V_{EN/SS}$ until the output voltage reaches 90% of the set voltage.
If the EN/SS pin voltage rises steeply without connecting C_{SS} and R_{SS} ($R_{SS} = 0\Omega$), Output rises with taking the soft-start time of $t_{ss1} = 1.0\text{ms}$ (TYP.) which is fixed internally.

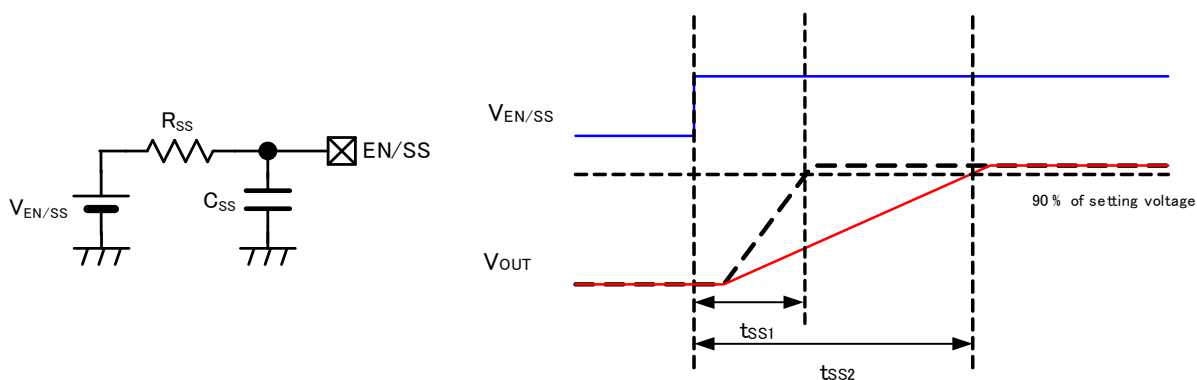

OPERATIONAL EXPLANATION

The XC9263/XC9264 series consists internally of a reference voltage supply with soft-start function, error amp, PWM comparator, ramp wave circuit, oscillator (OSC) circuit, phase compensation (Current feedback) circuit, current limiting circuit, current limit PFM circuit, High-side driver Tr., Low-side driver Tr., buffer drive circuit, internal power supply (LocalReg) circuit, under-voltage lockout (UVLO) circuit, gate clamp (CLAMP) circuit, thermal shutdown (TSD) circuit, power good comparator, control block and other elements.

The voltage feedback from the FB pin is compared to the internal reference voltage by the error amp, the output from the error amp is phase compensated, and the signal is input to the PWM comparator to determine the ON time of switching during PWM operation. The output signal from the error amp is compared to the ramp wave by the PWM comparator, and the output is sent to the buffer drive circuit and output from the LX pin as the duty width of switching. This operation is performed continuously to stabilize the output voltage.

The driver transistor current is monitored at each switching by the phase compensation (Current feedback) circuit, and the output signal from the error amp is modulated as a multi-feedback signal. This allows a stable feedback system to be obtained even when a low ESR capacitor such as a ceramic capacitor is used, and this stabilizes the output voltage.

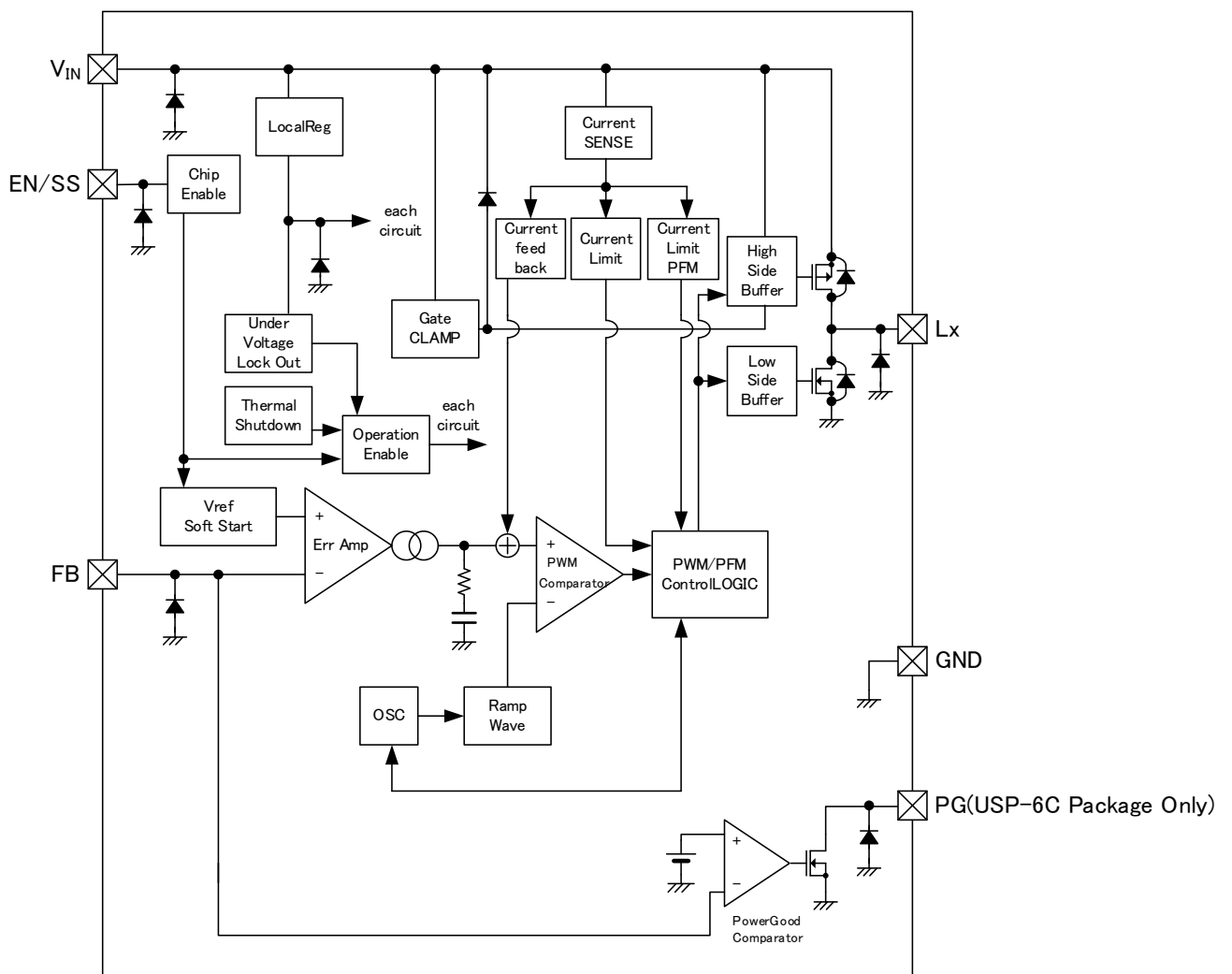

*Diodes inside the circuit are an ESD protection diodes and a parasitic diodes.

<Reference voltage source>

The reference voltage source provides the reference voltage to ensure stable output voltage of the DC/DC converter.

<Oscillator circuit>

The ramp wave circuit determines switching frequency. 500kHz or 1.2MHz or 2.2MHz is available for the switching frequency. Clock pulses generated in this circuit are used to produce ramp waveforms needed for PWM operation.

<Error amplifier>

The error amplifier is designed to monitor output voltage. The amplifier compares the reference voltage with the feedback voltage divided by the internal voltage divider, RFB1 and RFB2. When a voltage is lower than the reference voltage, then the voltage is fed back, the output voltage of the error amplifier increases. The error amplifier output is fixed internally to deliver an optimized signal to the mixer.

■ OPERATIONAL EXPLANATION (Continued)

<Current limiting>

The current limiting circuit of the XC9263/XC9264 series monitors the current that flows through the High-side driver transistor and Low-side driver transistor, and when over-current is detected, the current limiting function activates.

① High-side driver Tr. current limiting

The current in the High-side driver Tr. is detected to equivalently monitor the peak value of the coil current. The High-side driver Tr. current limiting function forcibly turns off the High-side driver Tr. when the peak value of the coil current reaches the High-side driver current limit value I_{LIMH} . When the over-current state is released, normal operation resumes.

② Low-side driver Tr. current limiting

The current in the Low-side driver Tr. is detected to equivalently monitor the bottom value of the coil current. The Low-side driver Tr. current limiting function prohibits the High-side driver Tr. from turning on in an over-current state where the bottom value of the coil current is higher than the Low-side driver Tr. current limit value I_{LIML} (TYP. 0.9A). Control to lower the switching frequency f_{OSC} is also performed. When the over-current state is released, normal operation resumes.

③ Over-current latch (Type A)

Type A turns off the High-side and Low-side driver Tr. when state ① or ② continues for t_{LAT} (TYP. 1.0ms). The Lx pin is latch-stopped at the GND level (0V).

The latch-stopped state only stops the pulse output from the Lx pin; the internal circuitry of the IC continues to operate. To restart after latch-stopping, L level and then H level must be input into the EN/SS pin, or VIN pin re-input must be performed (after lowering the voltage below the UVLO detection voltage) to resume operation by soft start.

The over-current latch function may occasionally be released from the current limit detection state by the effects of ambient noise, and it may also happen that the latch time becomes longer or latching does not take place due to board conditions. For this reason, place the input capacitor as close as possible to the IC.

Type B is an automatic recovery type that performs the operation of ① or ② until the over-current state is released.

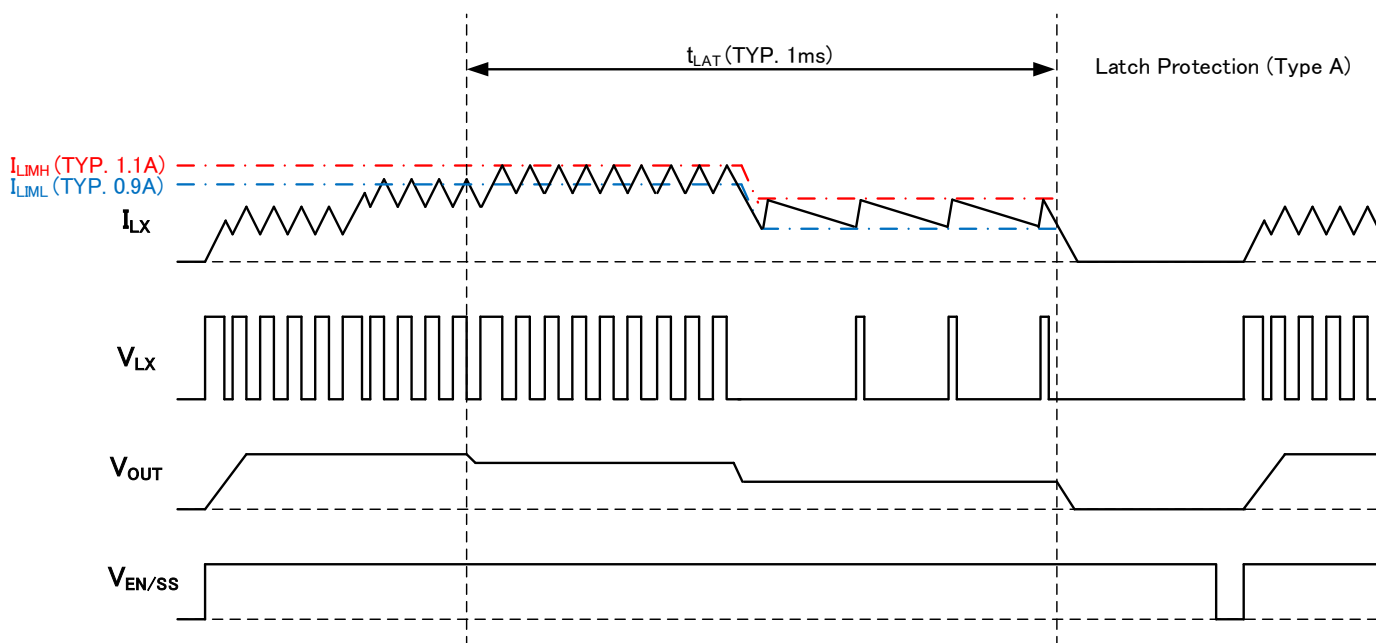

Current limiting timing chart

■ OPERATIONAL EXPLANATION (Continued)

<Soft-start function>

The reference voltage applied to the error amplifier is restricted by the start-up voltage of the EN/SS pin. This ensures that the error amplifier operates with its two inputs in balance, thereby preventing ON-time signal from becoming longer than necessary. Therefore, start-up time of the EN/SS pin becomes the set-time of soft-start. The soft-start time can be adjusted by adding a capacitor and a resistor to the EN/SS pin.

If the EN/SS pin voltage rises steeply without connecting C_{SS} and R_{SS} ($R_{SS}=0\Omega$), Output rises with taking the soft-start time of $t_{ss1}=1.0ms$ (TYP.) which is fixed internally.

The soft-start function operates when the voltage at the EN/SS pin is between 0.3V to 2.5V. If the voltage at the EN/SS pin does not start from 0V but from a middle level voltage when the power is switched on, the soft-start function will become ineffective and the possibilities of large inrush currents and ripple voltages occurring will be increased.

<Thermal shutdown>

The thermal shutdown (TSD) as an over current limit is built in the XC9263/XC9264 series.

When the junction temperature reaches the detection temperature, the driver transistor is forcibly turned off. When the junction temperature falls

to the release temperature while in the output stop state, restart takes place by soft-start.

<UVLO>

This is a function to monitor the internal power supply and to prevent the output of false pulses from the Lx pin when the output from the internal power supply is unstable at low voltages. As the V_{IN} pin voltage goes down, the internal power supply voltage falls. So the V_{IN} voltage drops, the UVLO function is activated.

When the V_{IN} pin voltage falls below V_{UVLO1} (TYP. 2.7V), the UVLO function is activated, the high side driver FET and low side driver FET are forcibly turned off to prevent false pulse output due to instable operation of the internal circuits. When the V_{IN} pin voltage rises above V_{UVLO2} (TYP. 2.8V), the UVLO function is released, the soft start function activates, and output start operation begins. Stopping by UVLO is not shutdown; only pulse output is stopped and the internal circuits continue to operate.

<Power good>

On USP-6C Package, the output state can be monitored using the power good function.

CONDITION		SIGNAL
EN/SS = H	$V_{FB} > V_{PGDET}$	H (High impedance)
	$V_{FB} \leq V_{PGDET}$	L (Low impedance)
	Thermal Shutdown	L (Low impedance)
	UVLO ($V_{IN} < V_{UVLO1}$)	Undefined State
EN/SS = L	Stand-by	L (Low impedance)

The PG pin is an Nch open drain output, therefore a pull-up resistance (approx. 100k Ω) must be connected to the PG pin. When not using the power good function, connect the PG terminal to GND or use it open.

■ NOTES ON USE

- 1) In the case of a temporary and transient voltage drop or voltage rise.
If the absolute maximum ratings are exceeded, the IC may deteriorate or be destroyed.

If a voltage exceeding the absolute maximum voltage is applied to the IC due to chattering caused by a mechanical switch or an external surge voltage, please use a protection element such as a TVS and a protection circuit as a countermeasure. Please see the countermeasures from (a) to (c) shown below.

(a) When voltage exceeding the absolute maximum ratings comes into the VIN pin due to the transient change on the power line, there is a possibility that the IC breaks down in the end.

To prevent such a failure, please add a TVS between VIN and GND as a countermeasure

(b) When the input voltage decreases below the output voltage, there is a possibility that an overcurrent will flow in the IC's internal parasitic diode and exceed the absolute maximum rating of the Lx pin.

If the current is pulled into the input side by the low impedance between VIN -GND, then countermeasures, such as adding an SBD between VOUT-VIN, should be taken.

(c) When a negative voltage is applied to the input voltage by a reverse connection or chattering, an overcurrent could flow in the IC's parasitic diode and damage the IC. Take countermeasures, such as adding a reverse touching protection diode

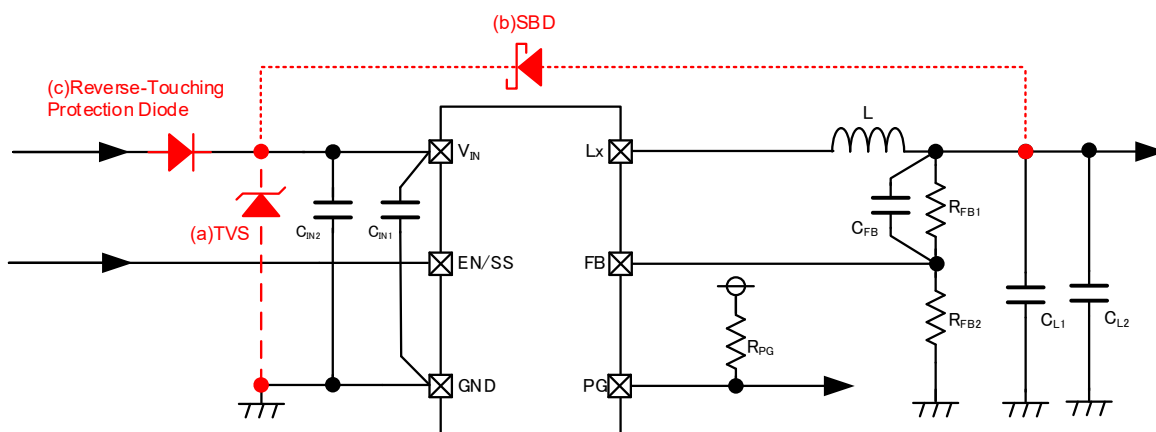

- 2) Make sure that the absolute maximum ratings of the external components and of this IC are not exceeded.
- 3) The DC/DC converter characteristics depend greatly on the externally connected components as well as on the characteristics of this IC, so refer to the specifications and standard circuit examples of each component when carefully considering which components to select.
Be especially careful of the capacitor characteristics and use B characteristics (JIS standard) or X7R, X5R (EIA standard) ceramic capacitors.
The capacitance decrease caused by the bias voltage may become remarkable depending on the external size of the capacitor.
- 4) If there is a large dropout voltage, then there might be pulse-skip during light loads even with PWM control.
- 5) The DC/DC converter of this IC uses a current-limiting circuit to monitor the coil peak current. If the potential dropout voltage is large or the load current is large, the peak current will increase, which makes it easier for current limitation to be applied which in turn could cause the operation to become unstable. When the peak current becomes large, adjust the coil inductance and sufficiently check the operation.
- 6) If there is a large dropout voltage, a circuit delay could create the ramp-up of coil current with staircase waveform exceeding the current limit.

NOTES ON USE (Continued)

- 7) The ripple voltage could be increased when switching from discontinuous conduction mode to Continuous conduction mode.
Please evaluate IC well on customer's PCB.
- 8) The operation of the IC becomes unstable below the minimum operating voltage.
- 9) If the voltage at the EN/SS Pin does not start from 0V but it is at the midpoint potential when the power is switched on, the soft start function may not work properly and it may cause the larger inrush current and bigger ripple voltages.
- 10) The effects of ambient noise and the state of the circuit board may cause release from the current limiting state, and the latch time may lengthen or latch operation may not take place. Please evaluate IC well on customer's PCB.
- 11) In order to drive the IC normally, supply a stable input voltage to the V_{IN} pin after reducing the AC impedance due to the bypass capacitor. In particular, if the amplitude of the input voltage fluctuates by 2V or more and $\pm 0.1V/\mu s$ or more, there is a possibility that the UVLO function malfunctions due to fluctuations of the internal power supply of the IC.
In that case, switching is stopped in a protected state that prevents false pulse output from the Lx pin. After that, the soft start function gets started, it shifts to normal operation.
If the input voltage fluctuates momentarily, take measures such as increasing the input capacitance.
- 12) Instructions of pattern layouts
The operation may become unstable due to noise and/or phase lag from the output current when the wire impedance is high, please place the input capacitor(C_{IN}) and the output capacitor (C_L) as close to the IC as possible.
 - (1) In order to stabilize V_{IN} voltage level, we recommend that a by-pass capacitor (C_{IN}) be connected as close as possible to the V_{IN} and GND pins. If fluctuation of the V_{IN} potential is expected, please take measures such as increasing input capacitor(C_{IN}).

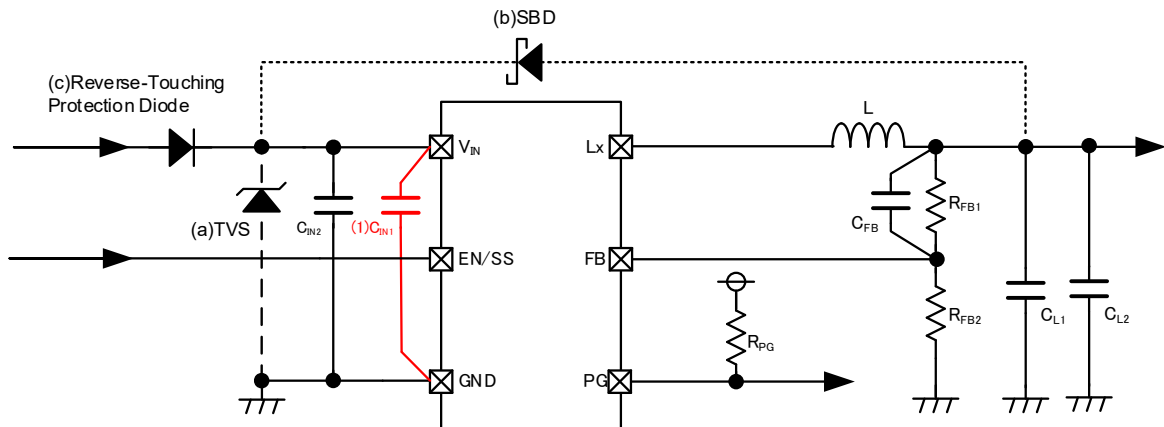

- (2) Please mount each external component as close to the IC as possible.
Please place the external parts on the same side of the PCB as the IC, not on the reverse side of the PCB and elsewhere.
- (3) Wire external components as close to the IC as possible and use thick, short connecting traces to reduce the circuit impedance.
- (4) Make sure that the GND traces are as thick as possible, as variations in ground potential caused by high ground currents at the time of switching may result in instability of the IC.
- (5) Please note that internal driver transistors bring on heat because of the load current and ON resistance of High-side driver transistor, Low-side driver transistor

■NOTES ON USE (Continued)

<Reference Pattern Layout>

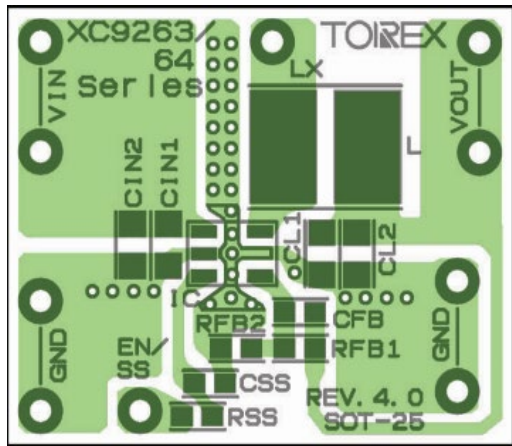

SOT-25(Front)

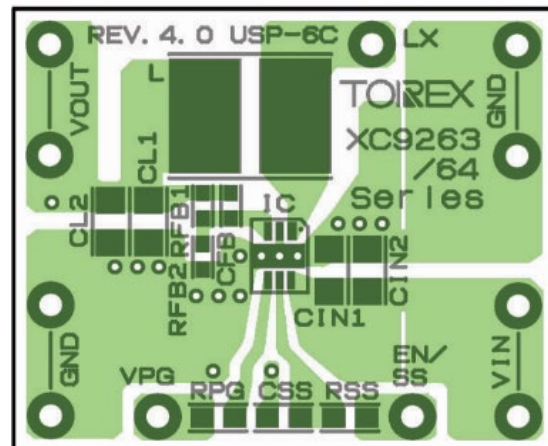

USP-6C(Front)

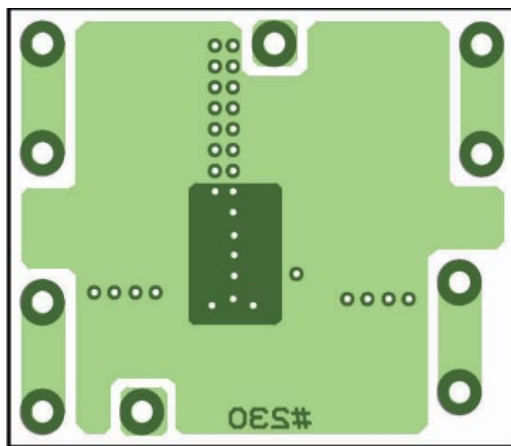

SOT-25(Back)

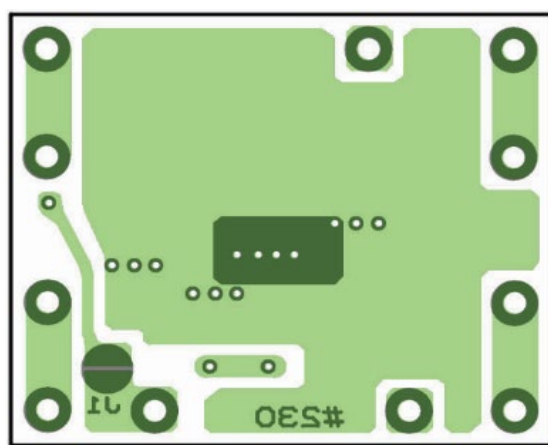

USP-6C(Back)

- 12) Torex places an importance on improving our products and their reliability. We request that users incorporate fail-safe designs and post-aging protection treatment when using Torex products in their systems.

TYPICAL PERFORMANCE CHARACTERISTICS

(1) Efficiency vs. Output current

XC9263x755/XC9264x755
($V_{IN}=12V$, $V_{OUT}=3.3V$, $f_{OSC}=500kHz$)

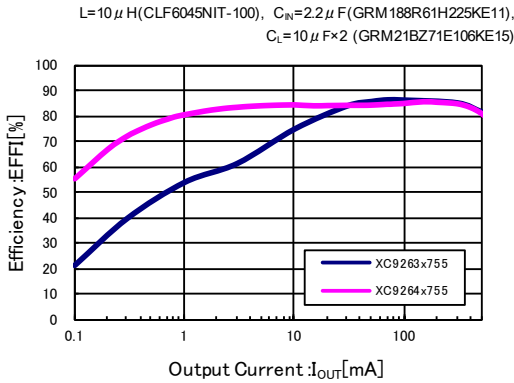

XC9263x755/XC9264x755
($V_{IN}=12V$, $V_{OUT}=5V$, $f_{OSC}=500kHz$)

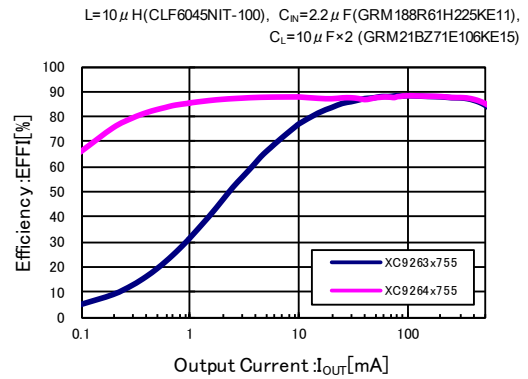

XC9263x75C/XC9264x75C
($V_{IN}=12V$, $V_{OUT}=3.3V$, $f_{OSC}=1200kHz$)

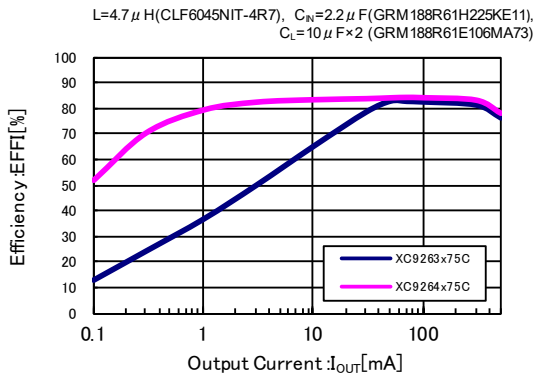

XC9263x75C/XC9264x75C
($V_{IN}=12V$, $V_{OUT}=5V$, $f_{OSC}=1200kHz$)

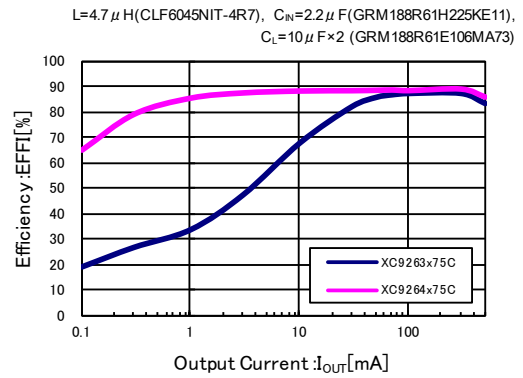

XC9263x75D/XC9264x75D
($V_{IN}=12V$, $V_{OUT}=3.3V$, $f_{OSC}=2200kHz$)

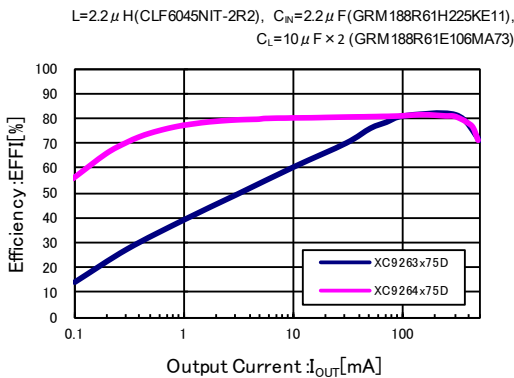

XC9263x75D/XC9264x75D
($V_{IN}=12V$, $V_{OUT}=5V$, $f_{OSC}=2200kHz$)

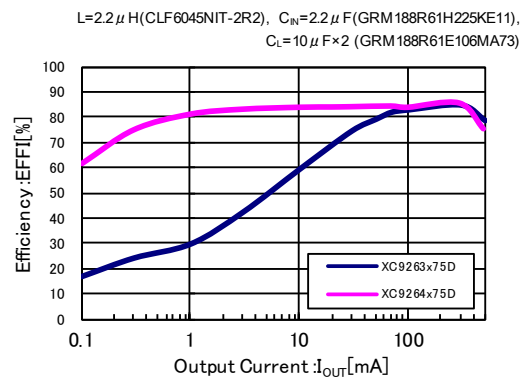

TYPICAL PERFORMANCE CHARACTERISTICS(Continued)

(2) Output Voltage vs. Output Current

XC9263x755/XC9264x755
($V_{IN}=12V$, $V_{OUT}=3.3V$, $f_{OSC}=500kHz$)

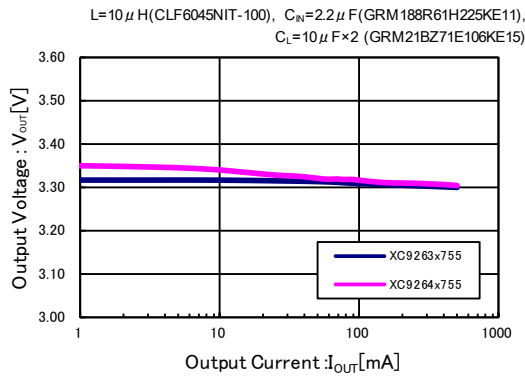

XC9263x755/XC9264x755
($V_{IN}=12V$, $V_{OUT}=5V$, $f_{OSC}=500kHz$)

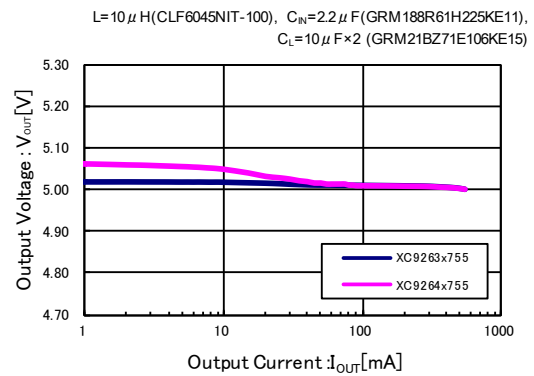

XC9263x75C/XC9264x75C
($V_{IN}=12V$, $V_{OUT}=3.3V$, $f_{OSC}=1200kHz$)

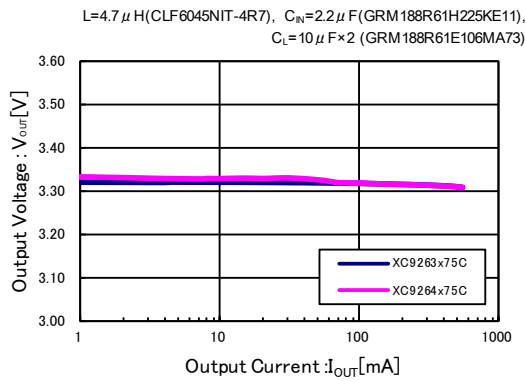

XC9263x75C/XC9264x75C
($V_{IN}=12V$, $V_{OUT}=5V$, $f_{OSC}=1200kHz$)

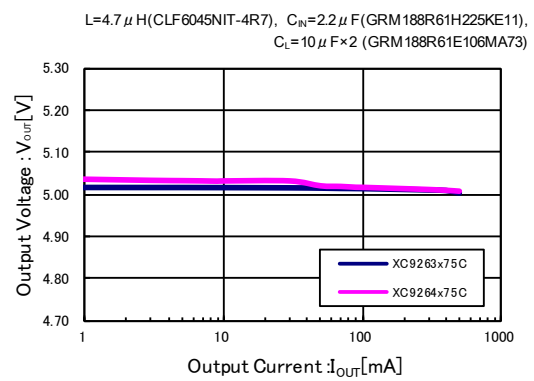

XC9263x75D/XC9264x75D
($V_{IN}=12V$, $V_{OUT}=3.3V$, $f_{OSC}=2200kHz$)

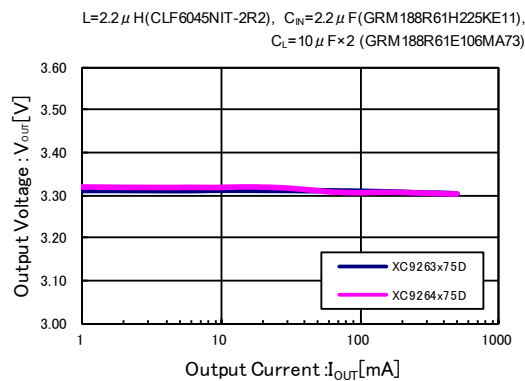

XC9263x75D/XC9264x75D
($V_{IN}=12V$, $V_{OUT}=5V$, $f_{OSC}=2200kHz$)

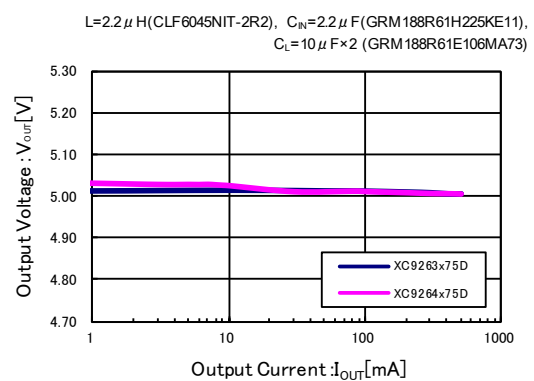

TYPICAL PERFORMANCE CHARACTERISTICS(Continued)

(3) Ripple Voltage vs. Output Current

XC9263x755/XC9264x755
($V_N=12V$, $V_{OUT}=5V$, $f_{OSC}=500kHz$)

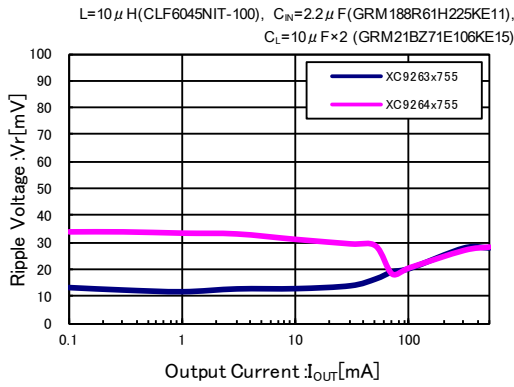

XC9263x75C/XC9264x75C
($V_N=12V$, $V_{OUT}=5V$, $f_{OSC}=1200kHz$)

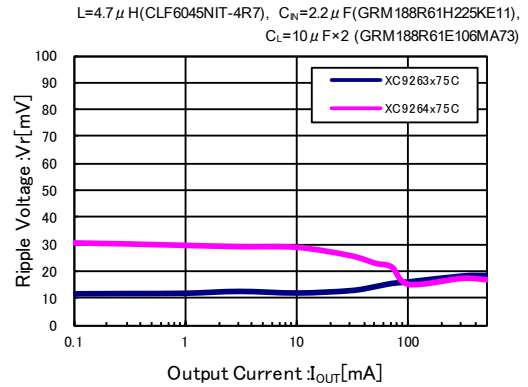

XC9263x75D/XC9264x75D
($V_N=12V$, $V_{OUT}=5V$, $f_{OSC}=2200kHz$)

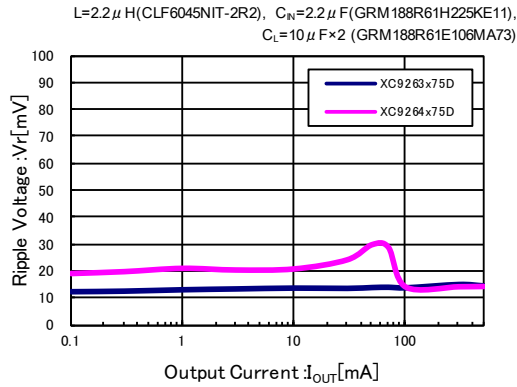

(4) FB Voltage vs. Ambient Temperature

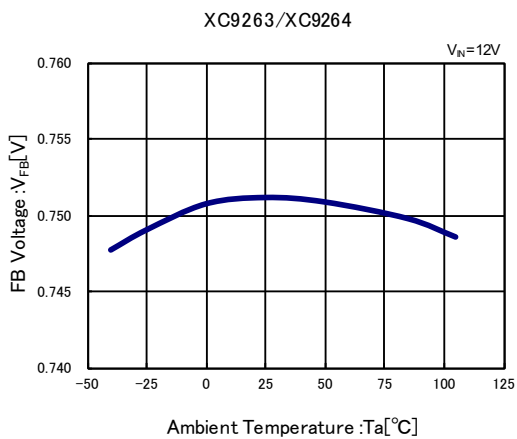

(5) UVLO Voltage vs. Ambient Temperature

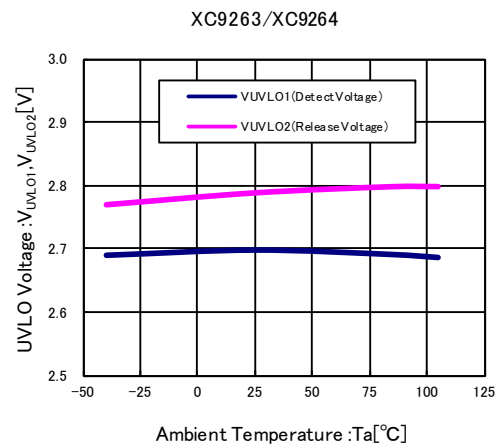

TYPICAL PERFORMANCE CHARACTERISTICS(Continued)

(6) Oscillation Frequency vs. Ambient Temperature

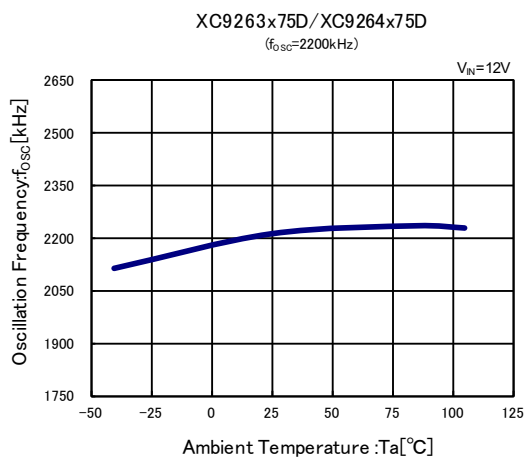
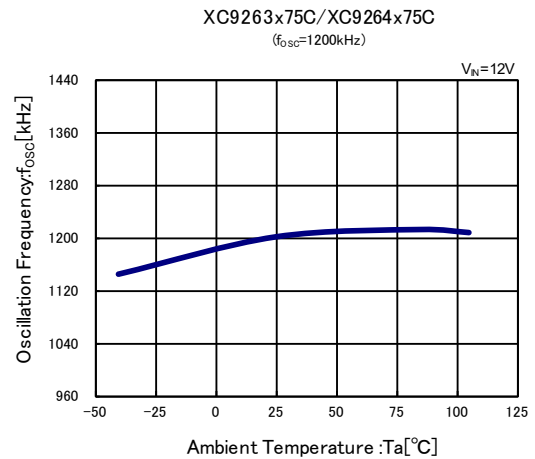
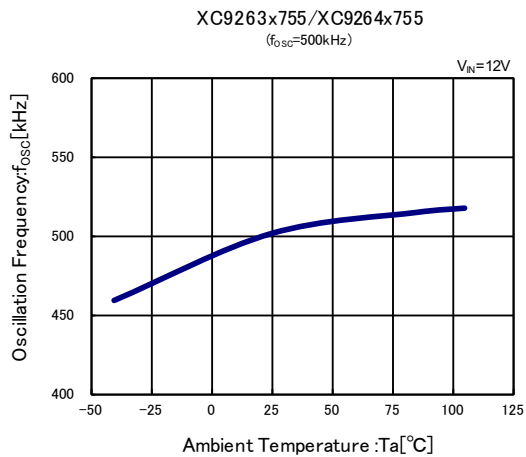

(7) Stand-by Current vs. Ambient Temperature

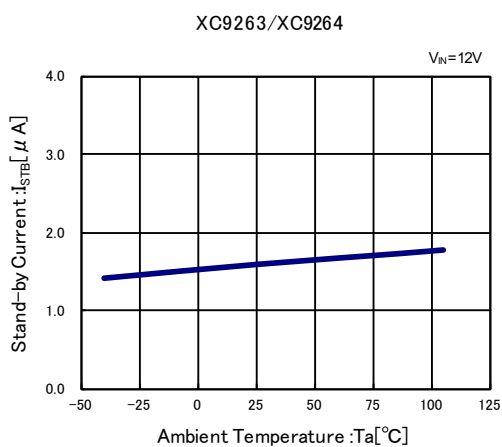

(8) Lx SW ON Resistance vs. Ambient Temperature

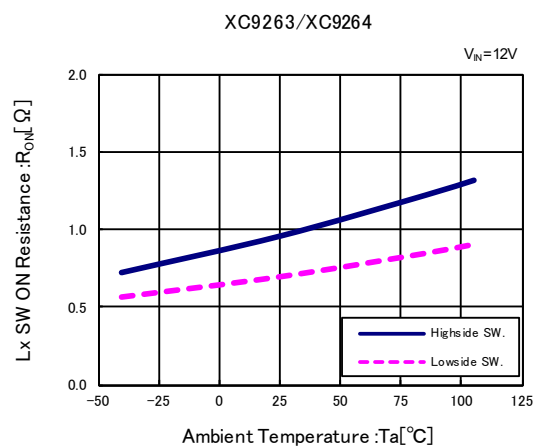

TYPICAL PERFORMANCE CHARACTERISTICS(Continued)

(9) Quiescent Current vs. Ambient Temperature

XC9263x755/XC9264x755
($f_{osc}=500kHz$)

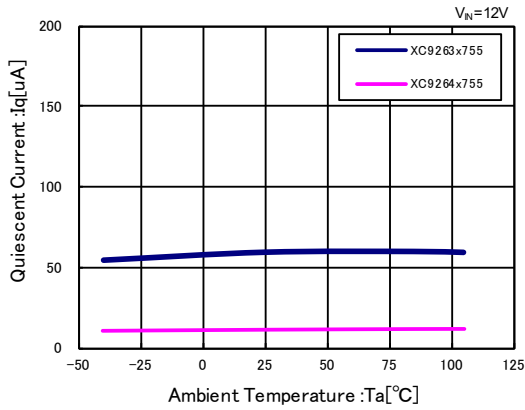

XC9263x75C/XC9264x75C
($f_{osc}=1200kHz$)

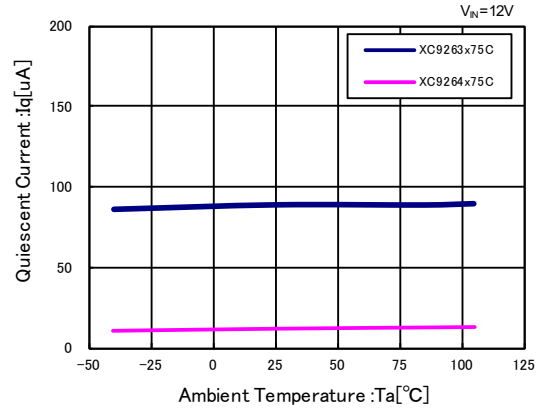

XC9263x75D/XC9264x75D
($f_{osc}=2200kHz$)

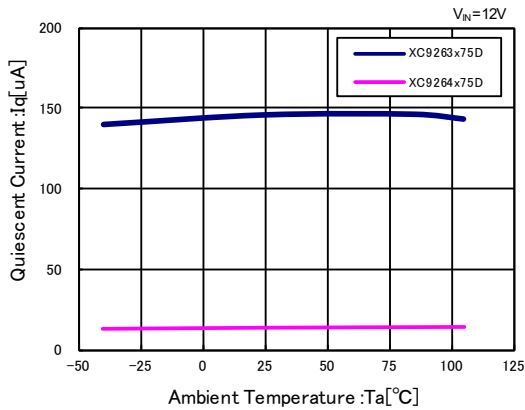

(10) Internal Soft-Start Time vs. Ambient Temperature

XC9263/XC9264

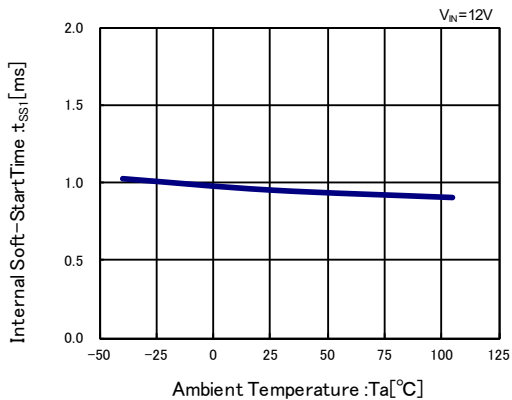

(11) External Soft-Start Time vs. Ambient Temperature

XC9263/XC9264

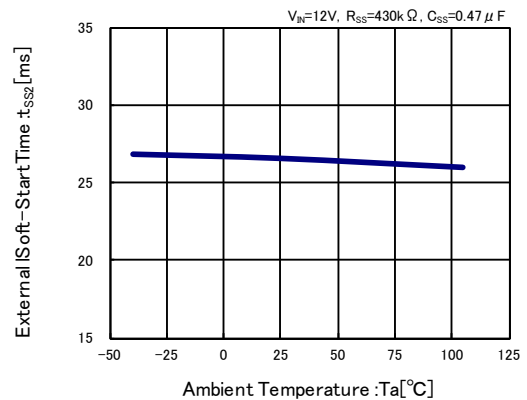

TYPICAL PERFORMANCE CHARACTERISTICS(Continued)

(12) PFM Current vs. Ambient Temperature

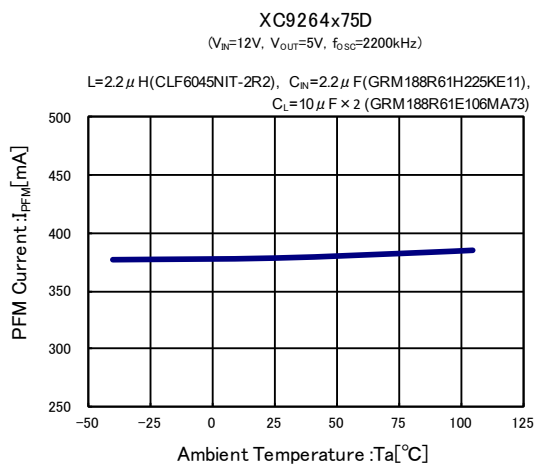
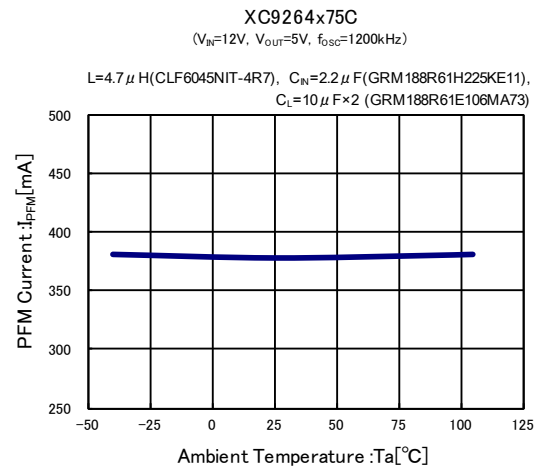
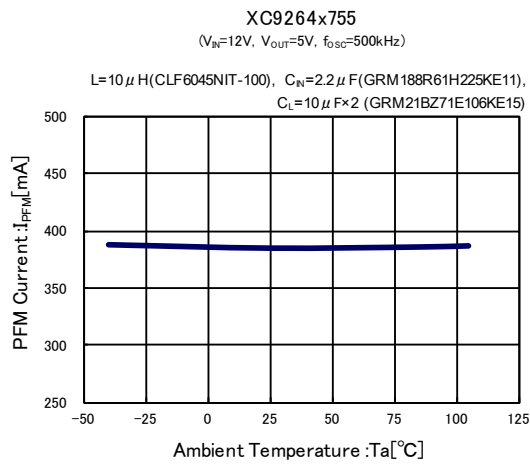

(13) PG Detect Voltage vs. Ambient Temperature

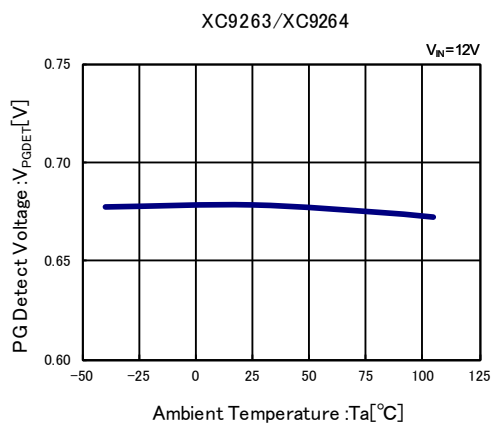

(14) PG Output Voltage vs. Ambient Temperature

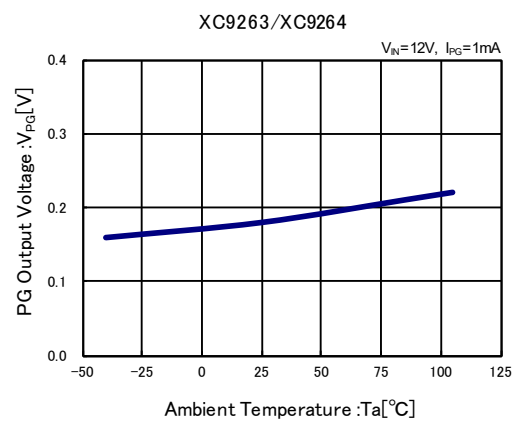

TYPICAL PERFORMANCE CHARACTERISTICS(Continued)

(15) EN/SS Voltage vs. Ambient Temperature

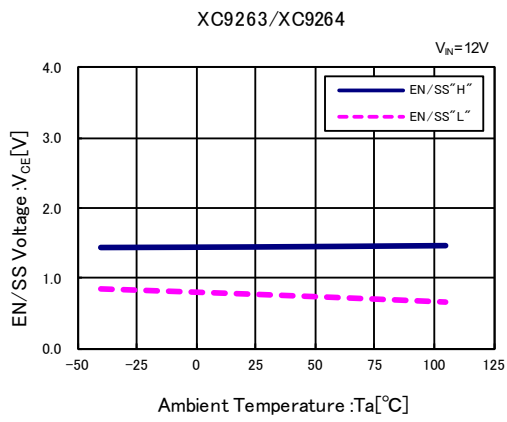

TYPICAL PERFORMANCE CHARACTERISTICS(Continued)

(16) Load Transient Response

XC9263x755, $f_{OSC}=500kHz$
 $V_N=12V, V_{OUT}=5.0V, I_{OUT}=1mA \rightarrow 300mA$

$L=10\mu H$ (CLF6045NIT-100), $C_N=2.2\mu F$ (GRM188R61H225KE11),
 $C_L=10\mu F \times 2$ (GRM21BZ71E106KE15)

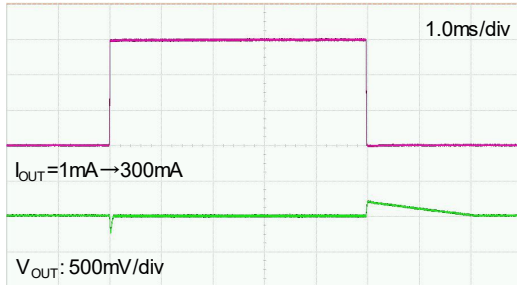

XC9264x755, $f_{OSC}=500kHz$
 $V_N=12V, V_{OUT}=5.0V, I_{OUT}=1mA \rightarrow 300mA$

$L=10\mu H$ (CLF6045NIT-100), $C_N=2.2\mu F$ (GRM188R61H225KE11),
 $C_L=10\mu F \times 2$ (GRM21BZ71E106KE15)

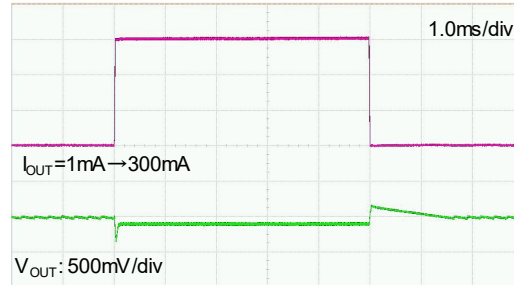

XC9263x75C, $f_{OSC}=1200kHz$
 $V_N=12V, V_{OUT}=5.0V, I_{OUT}=1mA \rightarrow 300mA$

$L=4.7\mu H$ (CLF6045NIT-4R7), $C_N=2.2\mu F$ (GRM188R61H225KE11),
 $C_L=10\mu F \times 2$ (GRM188R61E106MA73)



XC9264x75C, $f_{OSC}=1200kHz$
 $V_N=12V, V_{OUT}=5.0V, I_{OUT}=1mA \rightarrow 300mA$

$L=4.7\mu H$ (CLF6045NIT-4R7), $C_N=2.2\mu F$ (GRM188R61H225KE11),
 $C_L=10\mu F \times 2$ (GRM188R61E106MA73)

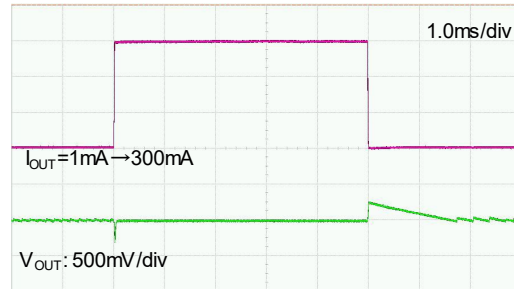

XC9263x75D, $f_{OSC}=2200kHz$
 $V_N=12V, V_{OUT}=5.0V, I_{OUT}=1mA \rightarrow 300mA$

$L=2.2\mu H$ (CLF6045NIT-2R2), $C_N=2.2\mu F$ (GRM188R61H225KE11),
 $C_L=10\mu F \times 2$ (GRM188R61E106MA73)

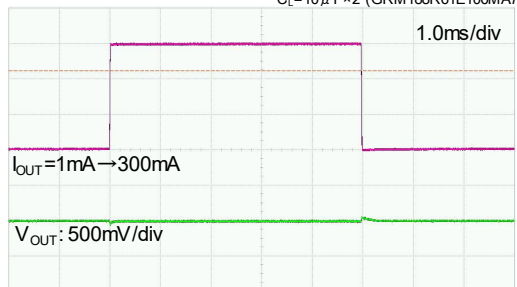

XC9264x75D, $f_{OSC}=2200kHz$
 $V_N=12V, V_{OUT}=5.0V, I_{OUT}=1mA \rightarrow 300mA$

$L=2.2\mu H$ (CLF6045NIT-2R2), $C_N=2.2\mu F$ (GRM188R61H225KE11),
 $C_L=10\mu F \times 2$ (GRM188R61E106MA73)

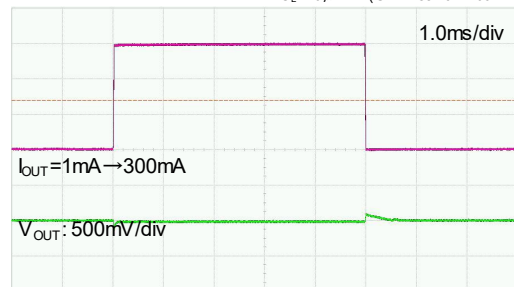

TYPICAL PERFORMANCE CHARACTERISTICS(Continued)

(17) Input Transient Response

XC9263x755, $f_{OSC}=500kHz$
 $V_N=12V \rightarrow 18V$, $V_{OUT}=5V$, $I_{OUT}=300mA$

$L=10\mu H$ (CLF6045NIT-100), $C_N=2.2\mu F$ (GRM188R61H225KE11),
 $C_L=10\mu F \times 2$ (GRM21BZ71E106KE15)

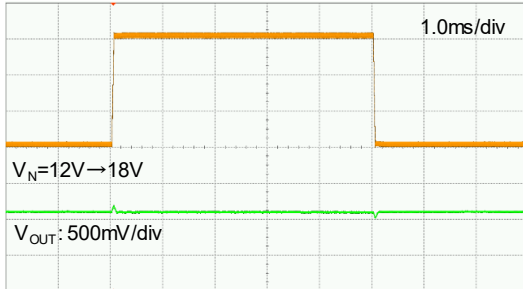

XC9264x755, $f_{OSC}=500kHz$
 $V_N=12V \rightarrow 18V$, $V_{OUT}=5V$, $I_{OUT}=300mA$

$L=10\mu H$ (CLF6045NIT-100), $C_N=2.2\mu F$ (GRM188R61H225KE11),
 $C_L=10\mu F \times 2$ (GRM21BZ71E106KE15)



XC9263x75C, $f_{OSC}=1200kHz$
 $V_N=12V \rightarrow 18V$, $V_{OUT}=5V$, $I_{OUT}=300mA$

$L=4.7\mu H$ (CLF6045NIT-4R7), $C_N=2.2\mu F$ (GRM188R61H225KE11),
 $C_L=10\mu F \times 2$ (GRM188R61E106MA73)



XC9264x75C, $f_{OSC}=1200kHz$
 $V_N=12V \rightarrow 18V$, $V_{OUT}=5V$, $I_{OUT}=300mA$

$L=4.7\mu H$ (CLF6045NIT-4R7), $C_N=2.2\mu F$ (GRM188R61H225KE11),
 $C_L=10\mu F \times 2$ (GRM188R61E106MA73)

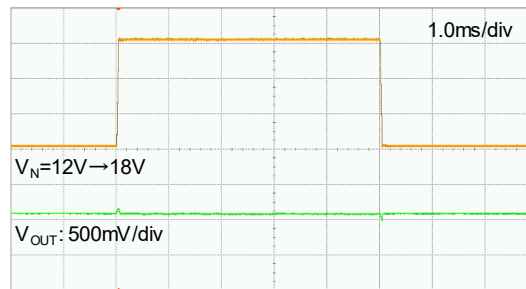

XC9263x75D, $f_{OSC}=2200kHz$
 $V_N=12V \rightarrow 18V$, $V_{OUT}=5V$, $I_{OUT}=300mA$

$L=2.2\mu H$ (CLF6045NIT-2R2), $C_N=2.2\mu F$ (GRM188R61H225KE11),
 $C_L=10\mu F \times 2$ (GRM188R61E106MA73)

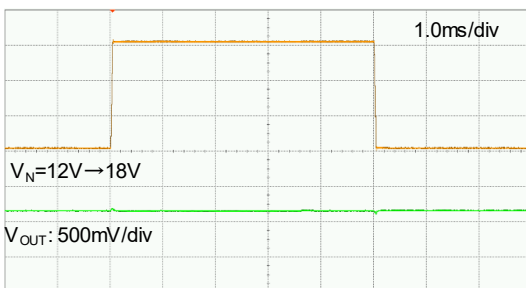

XC9264x75D, $f_{OSC}=2200kHz$
 $V_N=12V \rightarrow 18V$, $V_{OUT}=5V$, $I_{OUT}=300mA$

$L=2.2\mu H$ (CLF6045NIT-2R2), $C_N=2.2\mu F$ (GRM188R61H225KE11),
 $C_L=10\mu F \times 2$ (GRM188R61E106MA73)

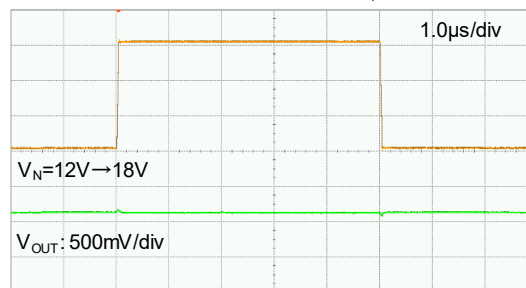

TYPICAL PERFORMANCE CHARACTERISTICS(Continued)

(18) EN/SS Rising Response

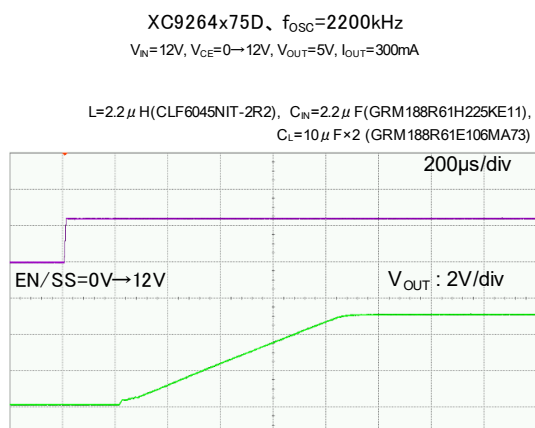
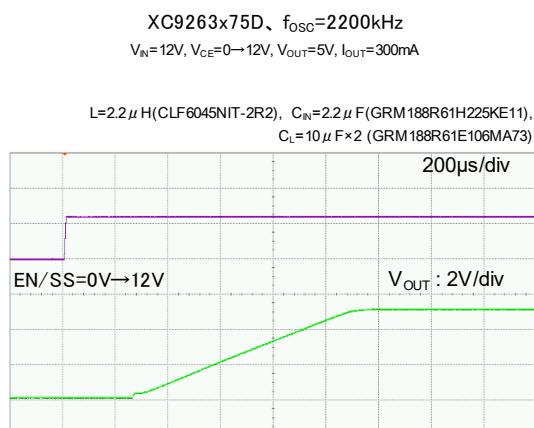
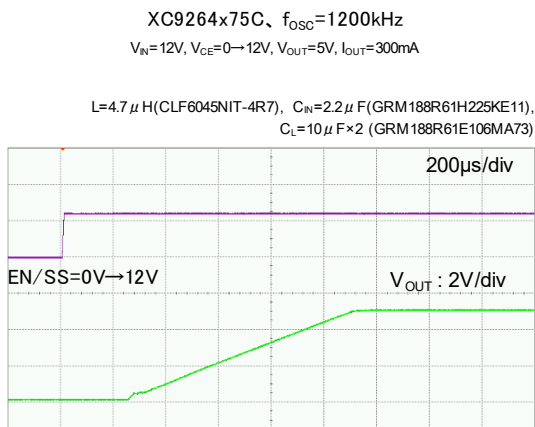
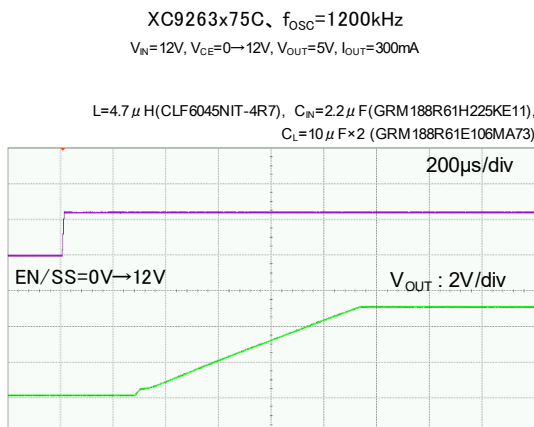
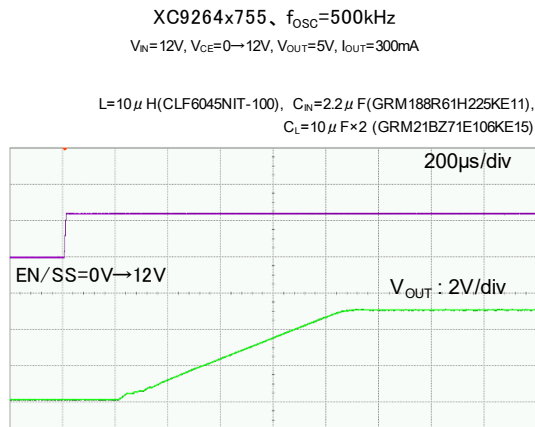
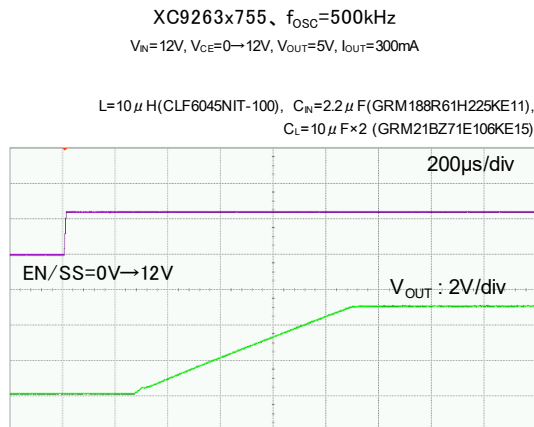

■ PACKAGING INFORMATION

For the latest package information go to, www.torexsemi.com/technical-support/packages

PACKAGE	OUTLINE / LAND PATTERN	THERMAL CHARACTERISTICS
SOT-25	SOT-25 PKG	SOT-25 Power Dissipation
USP-6C	USP-6C PKG	USP-6C Power Dissipation

MARKING RULE

●SOT-25(Under dot) / USP-6C

●SOT-25 (Under dot)

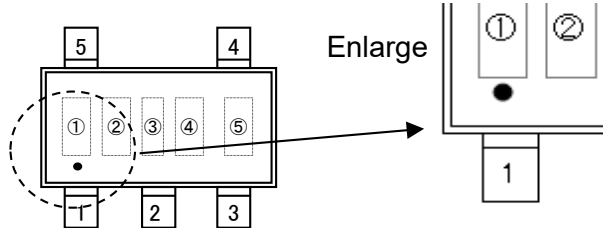

●USP-6C

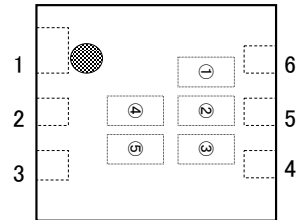

①②③ represents products series, products type, Oscillation Frequency

MARK			SERIES	TYPE	OSCILLATION FREQUENCY	PRODUCT SERIES
①	②	③				
1	1	A	XC9263	A	5	XC9263A755xx-G
1	1	B	XC9263	A	C	XC9263A75Cxx-G
1	1	C	XC9263	A	D	XC9263A75Dxx-G
1	1	D	XC9263	B	5	XC9263B755xx-G
1	1	E	XC9263	B	C	XC9263B75Cxx-G
1	1	F	XC9263	B	D	XC9263B75Dxx-G
1	1	H	XC9264	A	5	XC9264A755xx-G
1	1	K	XC9264	A	C	XC9264A75Cxx-G
1	1	L	XC9264	A	D	XC9264A75Dxx-G
1	1	M	XC9264	B	5	XC9264B755xx-G
1	1	N	XC9264	B	C	XC9264B75Cxx-G
1	1	P	XC9264	B	D	XC9264B75Dxx-G

④⑤ represents production lot number

01~09, 0A~0Z, 11~9Z, A1~A9, AA~AZ, B1~ZZ in order.

(G, I, J, O, Q, W excluded)

* No character inversion used.

1. The product and product specifications contained herein are subject to change without notice to improve performance characteristics. Consult us, or our representatives before use, to confirm that the information in this datasheet is up to date.
2. The information in this datasheet is intended to illustrate the operation and characteristics of our products. We neither make warranties or representations with respect to the accuracy or completeness of the information contained in this datasheet nor grant any license to any intellectual property rights of ours or any third party concerning with the information in this datasheet.
3. Applicable export control laws and regulations should be complied and the procedures required by such laws and regulations should also be followed, when the product or any information contained in this datasheet is exported.
4. The product is neither intended nor warranted for use in equipment of systems which require extremely high levels of quality and/or reliability and/or a malfunction or failure which may cause loss of human life, bodily injury, serious property damage including but not limited to devices or equipment used in 1) nuclear facilities, 2) aerospace industry, 3) medical facilities, 4) automobile industry and other transportation industry and 5) safety devices and safety equipment to control combustions and explosions. Do not use the product for the above use unless agreed by us in writing in advance.
5. Although we make continuous efforts to improve the quality and reliability of our products; nevertheless Semiconductors are likely to fail with a certain probability. So in order to prevent personal injury and/or property damage resulting from such failure, customers are required to incorporate adequate safety measures in their designs, such as system fail safes, redundancy and fire prevention features.
6. Our products are not designed to be Radiation-resistant.
7. Please use the product listed in this datasheet within the specified ranges.
8. We assume no responsibility for damage or loss due to abnormal use.
9. All rights reserved. No part of this datasheet may be copied or reproduced unless agreed by Torex Semiconductor Ltd in writing in advance.

TOREX SEMICONDUCTOR LTD.