

REVISIONS

P	LTR	DESCRIPTION	DATE	DWH	APVD
A1		PCN E-20-009212	22MAY2020	MK	GL
A2		PCN E-20-012159	27AUG2020	MK	GL
A3		PCN E-20-014520	13OCT2020	MK	GL
A4		PCN E-21-002058	12FEB2021	PN	GL

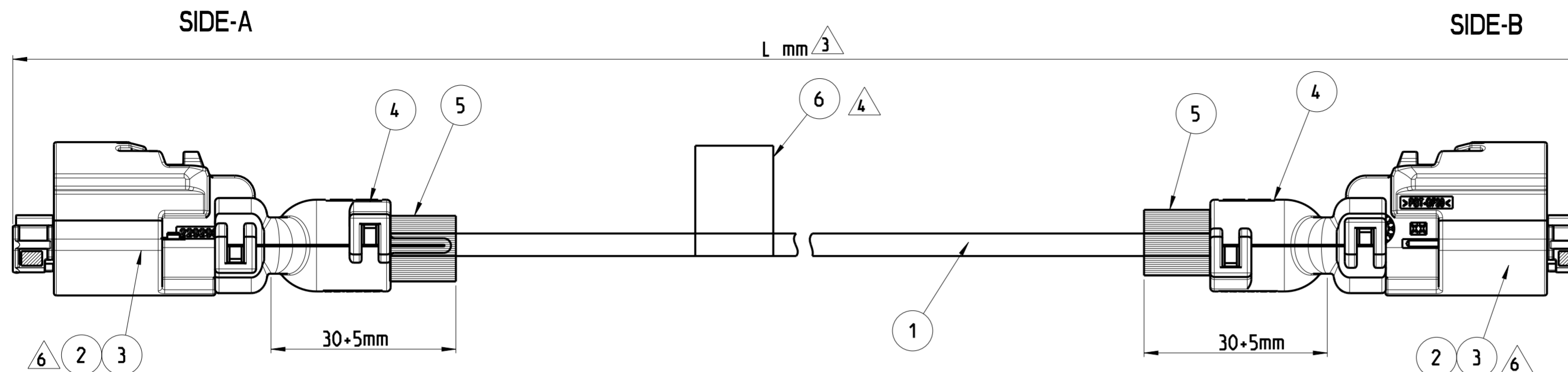

TABLE LEGEND:

TE CONNECTIVITY : TE PN : SEE TABLE REV : SEE TABLE YYCWD

LENGTH SCHEDULE

TE PN	REV	ALIAS PART NO	LENGTH L (mm)	TOL (mm)
2362353-1	A	UTPB-ESFSA-ESFSA-500	500	+20
2362353-2	A	UTPB-ESFSA-ESFSA-100	1000	+20
2362353-3	A	UTPB-ESFSA-ESFSA-1500	1500	+30
2362353-4	A	UTPB-ESFSA-ESFSA-3000	3000	+40
2362353-5	A	UTPB-ESFSA-ESFSA-5000	5000	+40

WIRE COLOUR SCHEDULE

MCON 1.2 RECEPTACLE	CAVITY#	SIDE A	SIDE B	MCON 1.2 RECEPTACLE
	1	WHITE	WHITE	
	2	BLUE	BLUE	

NOTES :

- 1 PACKAGING: ASSEMBLY IN TE STANDARD CARTON
- 2 ELECTRICAL TEST: 100% FOR SHORT CIRCUIT ACC. TE SPECIFICATION 108-18857. STANDARD TEST 3.1.1 a.b.d AND 3.1.2 d.e.m.
- LENGTH "L" ACCORDING TABLE IS FOR STRAIGHT CABLE.
- LABEL PRINT SEE LABEL LEGEND
- 5 APPLICATION SPECIFICATION FOR enetSEAL 114-151045 APPLICATION SPECIFICATION FOR MCON 1.2 mm CONTACT SYSTEM 114-18464 INSTRUCTION SHEET FOR 1.2-mm MCON WIRE DRESS COVER 408-32185
- RETAINER PRESENT AND CLOSED.
- REFER LENGTH SCHEDULE.

1	LABEL 60 X 50 MM	6
30±5mm	RNF 100 1/4 BK SP	5
2	MCON WIRE DRESS COVER. 2 POS PLUG. STRAIGHT	4
4	MCON 1.2 CB REC SRC Au	3
2	PLUG ASSEMBLY. SEALED. 2 POSITION MCON 1.2 CB	2
see table	2 POS. CABLE. 0.5 SQMM. ETHERNET. CHAMPLAIN	1
QTY	DESCRIPTION	ITEM NO.

PRODUCT CHARACTERISTICS ACC. QMP EMEA_12 BESONDERE MERKMALE NACH QMP EMEA_12		TOLERANCING ISO 8015 TOLERIERUNG ISO 8015	
DIESE ZEICHNUNG IST EIN KONTROLLIERTES DOKUMENT. BEMASSUNGEN UND TOLERANZEN GEMAESS GPS (ISO STANDARDS).			
THIS DRAWING IS A CONTROLLED DOCUMENT.			
DIMENSIONS: mm		TOLERANCES UNLESS OTHERWISE SPECIFIED:	
		0 PLC	±
		1 PLC	±
		2 PLC	±
		3 PLC	±
		4 PLC	±
		ANGLES	±
		FINISH	±
MATERIAL	-	WEIGHT	-
		CUSTOMER DRAWING	

DWH 27APR2020 CHK T. BAYRAM 27APR2020 APVD G. LINDEMANN 27APR2020		NAME ENETSEAL- FEMALE TO FEMALE CABLE ASSY	
SIZE A2	CAGE CODE 00779	DRAWING NO C-2362353	RESTRICTED TO
SCALE 2:1		SHEET 1 OF 1	REV A4