

Designing Effective Circuit Protection for RS-485 and RS-422 Applications

WHITE PAPER



*Bourns® TBU-RS Series
TBU® High-Speed Protectors*



*Bourns® TISP® Thyristor Surge
Protectors*



Bourns® Gas Discharge Tubes (GDTs)



*Bourns® GMOV™ / IsoMOV™
Hybrid Protection Components*



Bourns® Metal Oxide Varistors (MOVs)

INTRODUCTION

The requirement to support data and/or sensor information collection to maximize business productivity is driving next-generation designs. In many industrial settings, the popular RS-485 interface is used for this function. For new and legacy RS-485, RS-422 and other differential communication-based applications, there is a need for balanced, complete circuit protection that includes overcurrent protection as well as overvoltage protection.

Historically, it has been a challenge to incorporate a protection solution that meets application demands while providing reliable operation in hostile environmental conditions. Bulky protection solutions often consist of optical and logic components providing galvanic isolation, requiring many components and isolated power supplies. Protection is also provided by steering diodes, series resistors, and TVS protection diodes. Complex foldback current limiting designs are also used which consist of many components, some of which need their own overvoltage protection. More robust protection typically results in higher capacitance on the lines which limits the data rate.

The availability of advanced protection technologies now makes protection possible with low capacitance, allowing the maximum data rates. The protection provided by innovative, integrated overcurrent detection and low capacitance TVS components enables communication systems with the highest levels of protection and data rates. This allows developers to remain focused on their system design.

This paper will show how the Bourns® TBU-RS Series High-Speed Protectors (HSPs) protect differential communication lines. Similar to what is required for the majority of wired communication systems, threats such as system transients, lightning, and power surges caused by high power motors and other electrical equipment must be considered during the design. These include ESD, lightning surges of 4 kV and 2 kA, power induction such as 600 V_{rms} for up to one second, longer duration moderate voltage power cross, and Earth Potential Rise (EPR or GPR).



Designing Effective Circuit Protection for RS-485 and RS-422 Applications

A DUAL-CHANNEL BIDIRECTIONAL SOLUTION

Committed to continually addressing unique circuit protection needs across a variety of sensitive applications, Bourns designed its Model TBU-RS Series HSP as a space-saving, cost-effective secondary protection solution to protect against induced lightning, ESD surges, installation errors, cabling faults and associated issues. Together with the appropriate primary protection, the Bourns® TBU-RS Series HSP will block faults with high current and voltage, up to the limitations of the primary protection components. Designed as a complete, simple-to-use protector circuit, it can be used on many different data and sense lines for balanced protection on a printed wiring board, in half of the area required for separate components. See Figure 1a illustrating the reduced number of components required compared to Figure 1b.

What makes the TBU-RS device particularly useful in RS-485 and RS-422 applications is that it offers dual-channel bidirectional protection matching the interface's differential, bidirectional qualities, including an integrated signal level transient voltage suppressor (TVS). That means a single TBU-RS device can be used for each differential signal pair, so one side is connected to the positive signal line and the other to the negative signal line. This makes it easier to place and route the application circuit board, reduce the component count, and ensure consistent operation, balance, and performance for a differential pair.



Bourns® TBU-RS Series
TBU® High-Speed Protectors



Bourns® TISP® Thyristor Surge
Protectors



Bourns® Gas Discharge Tubes (GDTs)



Bourns® GMOV™ / IsoMOV™
Hybrid Protection Components



Bourns® Metal Oxide Varistors (MOVs)

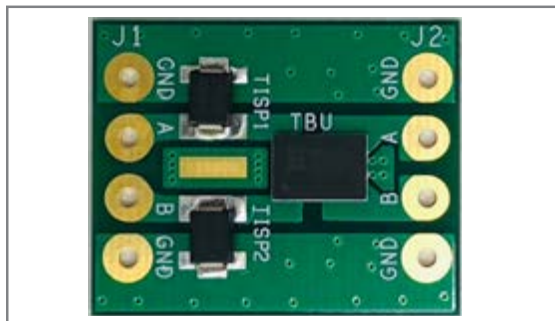

Figure 1a - TBU-RS Series TBU® HSP evaluation PCB.

With so many variables to account for in coordinating multi-stage solutions, using the Bourns® TBU-RS Series HSP solution allows the designer to spend more time on the actual design. It helps ensure reliable performance regardless of cable length, data rate, number of nodes, and other devices present in the RS-485 network. Plus, the dual-channel TBU-RS Series HSP does not introduce unbalanced impedance, inductance, or capacitance to the RS-485 network.

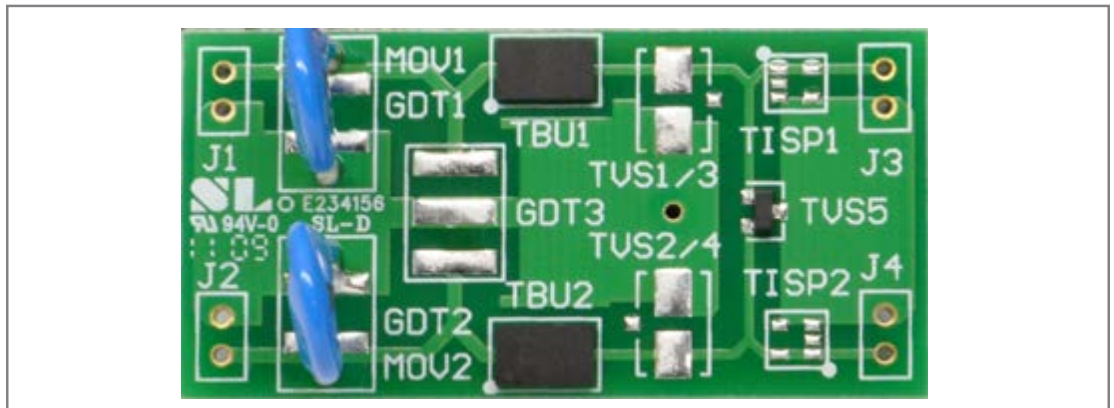

Figure 1b - TBU® HSP evaluation PCB without the integration of TBU® HSP and TVS components into a single device.



Designing Effective Circuit Protection for RS-485 and RS-422 Applications



*Bourns® TBU-RS Series
TBU® High-Speed Protectors*



*Bourns® TISP® Thyristor Surge
Protectors*



Bourns® Gas Discharge Tubes (GDTs)



*Bourns® GMOV™ / IsoMOV™
Hybrid Protection Components*



Bourns® Metal Oxide Varistors (MOVs)

MULTI-STAGE CIRCUIT PROTECTION

Overvoltage circuit protection is used as primary circuit protection for these new TBU-RS Series HSP devices. Overvoltage circuit protection can either make a path for the current to ground or clamp the voltage to a tolerable upper limit.

Designers often use multiple stages of circuit protection that are coordinated as shown in Figure 2. This example uses thyristor surge protectors, which Bourns markets under the TISP® brand, for primary protection and the TBU-RS Series for secondary protection. The TBU-RS Series HSP device functions to block excessive line current and prevent damage to line drivers, line receivers, and other interface components. The TBU-RS Series detects excess current and provides a high series impedance to block the current flow.

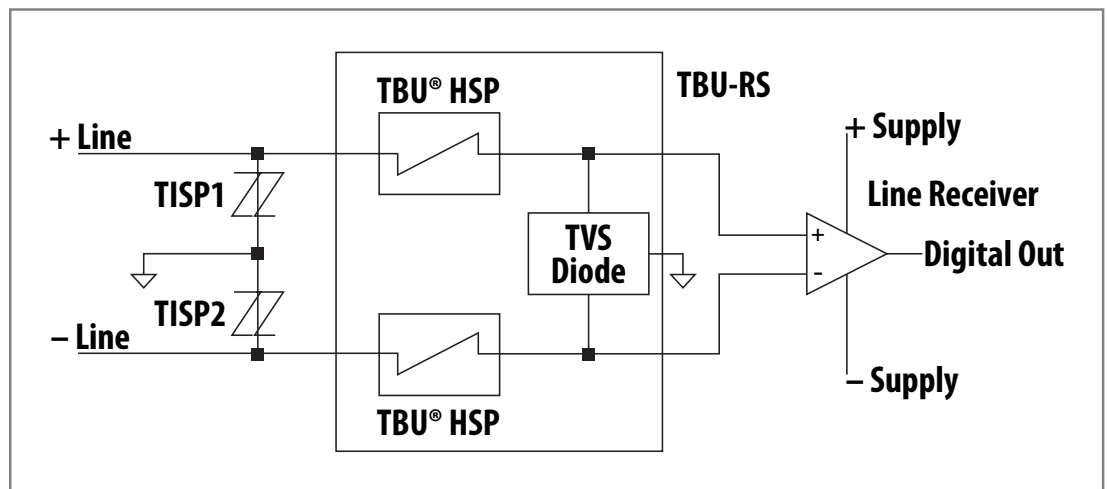

Figure 2 - Bourns® Model TBU-RS Series TBU® HSP with TISP® Overvoltage Protection on an RS-485 Interface.

The TBU-RS Series HSP includes a specification for maximum voltage for safe operation. If the surge voltage is expected to exceed this, then an overvoltage primary protector such as a Metal Oxide Varistor (MOV), Bourns® TISP® thyristor surge protector, Gas Discharge Tube (GDT), or Bourns® GMOV™ or IsoMOV™ hybrid overvoltage protector can be connected from the signal lines to ground to limit the voltage across the TBU® HSP. In applications with sensitive data bandwidth, a GDT or a GMOV™ or IsoMOV™ hybrid surge protector is typically recommended for overvoltage protection because of the lower capacitance of these devices.



Designing Effective Circuit Protection for RS-485 and RS-422 Applications

MULTI-STAGE CIRCUIT PROTECTION (Continued)



*Bourns® TBU-RS Series
TBU® High-Speed Protectors*



*Bourns® TISP® Thyristor Surge
Protectors*



Bourns® Gas Discharge Tubes (GDTs)



*Bourns® GMOV™ / IsoMOV™
Hybrid Protection Components*



Bourns® Metal Oxide Varistors (MOVs)

The primary protector is chosen for the required level of surge current. The Bourns® TISP® bidirectional thyristor overvoltage protector is ideal for most situations where a TBU-RS Series TBU® HSP would be used for protection. A Bourns® TISP® device has the capability to withstand the expected surges, plus it is small and has low capacitance to avoid distorting the RS-485 signal. Using the same type on each signal line to ground maintains the balanced structure of the transmission line as shown in Figure 2. Figure 3 indicates the Bourns® TISP® device part numbers required, depending on the protection level needed.

GDTs are also used as primary protectors for the highest classes of protection. The following aspects should be considered when specifying a primary protector: it must be fast enough to limit the voltage, robust enough to handle the surge current, small enough to fit the available space, economically affordable, and have a low capacitance characteristic so it will not distort the RS-485 signal or limit the design's specified data rates.

A GDT may be necessary to protect the TBU® HSP if the expected surge current is over 1000 amps. Keeping a balanced arrangement, a two chamber GDT is the best solution for protecting both signal lines at the same time. Individual GDTs may be used, one on each line, for the required surge protection. However, they will not minimize the effects of a voltage surge on one line only. Two individual GDTs will cause an unbalanced voltage surge on the inputs to the communication interface when a longitudinal surge is impressed on the communication lines. In the case of the two chamber GDT, a surge on one line will cause a low impedance on both lines simultaneously.

During normal operation, the Bourns® TBU® HSP presents a low, defined series resistance to the line. As transient current increases to the TBU® device's trigger level, the TBU® HSP device will switch to a very high impedance, which is its protection state. Regardless of the incident transient signal characteristics, this transition occurs in less than one microsecond. The Bourns® TBU® HSP will reset when the voltage across it drops below the required reset voltage (V_{reset}). The internal TVS diode limits the voltage to safe levels for the communication components.



Designing Effective Circuit Protection for RS-485 and RS-422 Applications

MULTI-STAGE CIRCUIT PROTECTION (Continued)

The specific primary protector recommendation depends on the exposure environment and severity level of surges that the application will experience. Figure 3 shows the primary Bourns® protectors that can be used in various surge environments to mitigate several levels of surges.



*Bourns® TBU-RS Series
TBU® High-Speed Protectors*



*Bourns® TISP® Thyristor Surge
Protectors*



Bourns® Gas Discharge Tubes (GDTs)



*Bourns® GMOV™ / IsoMOV™
Hybrid Protection Components*



Bourns® Metal Oxide Varistors (MOVs)

Figure 3 | Primary Bourns® protectors and TBU® HSPs in communication protection applications.

| IEC 61000-4-5 Class | Peak Test (V) | Generator Impedance | | |
|---------------------|---------------|---|---|--|
| | | Req = 42 Ω | Req = 12 Ω | Req = 2 Ω |
| 0 | 25 V | <i>TBU-RS055-300-WH</i> | <i>TBU-RS055-300-WH</i> | <i>TBU-RS055-300-WH</i> |
| 1 | 500 V | <i>TBU-RS055-300-WH</i> | <i>TBU-RS055-300-WH</i> <i>TISP4350H3BJR-S</i> | <i>TBU-RS055-300-WH</i> <i>TISP4350H3BJR-S</i> |
| 2 | 1 kV | <i>TBU-RS055-300-WH</i> <i>TISP4350H3BJR-S</i> | <i>TBU-RS055-300-WH</i> <i>TISP4350H3BJR-S</i> | <i>TBU-RS085-300-WH</i> <i>TISP4350J3BJR-S</i> |
| 3 | 2 kV | <i>TBU-RS055-300-WH</i> <i>TISP4350H3BJR-S</i> | <i>TBU-RS055-300-WH</i> <i>TISP4350H3BJR-S</i> | <i>TBU-RS085-300-WH</i> <i>GDT 2030-23T-SM-RPLF</i> |
| 4 | 4 kV | <i>TBU-RS085-300-WH</i> <i>TISP4350J3BJR-S</i> | <i>TBU-RS085-300-WH</i> <i>TISP4350J3BJR-S</i> | <i>TBU-RS085-300-WH</i> <i>GDT 2036-23-SM-RPLF</i> |



Designing Effective Circuit Protection for RS-485 and RS-422 Applications

EVALUATION RESOURCE



[Bourns® TBU-RS Series TBUSM1000 High-Speed Protectors](#)



[Bourns® TISP® Thyristor Surge Protectors](#)



[Bourns® Gas Discharge Tubes \(GDTs\)](#)



[Bourns® GMOV™ / IsoMOV™ Hybrid Protection Components](#)



[Bourns® Metal Oxide Varistors \(MOVs\)](#)

As a valuable resource that helps demonstrate the effectiveness and simplicity of this solution firsthand, Bourns offers an evaluation board as shown in Figure 1. There is no need to breadboard and swap component values over multiple stages until the optimal solution is found. The coordinated components installed on the evaluation board are selected as ideal solutions for RS-485 protection. Measurements and tests performed with the evaluation board should closely resemble the performance of the deployed product. Similarly, the expected conditions can be simulated to help ensure the voltage level across the TBU-RS Series HSP will be within ratings.

The test setup for the TBU-RS Series evaluation PCB is shown in Figure 4. The surge generator is connected between inputs Line A or Line B and ground. At this point, the peak surge voltage is measured. The maximum voltage reaching the communication components is measured at points A and B, at the TVS output from the TBU-RS protection circuit.

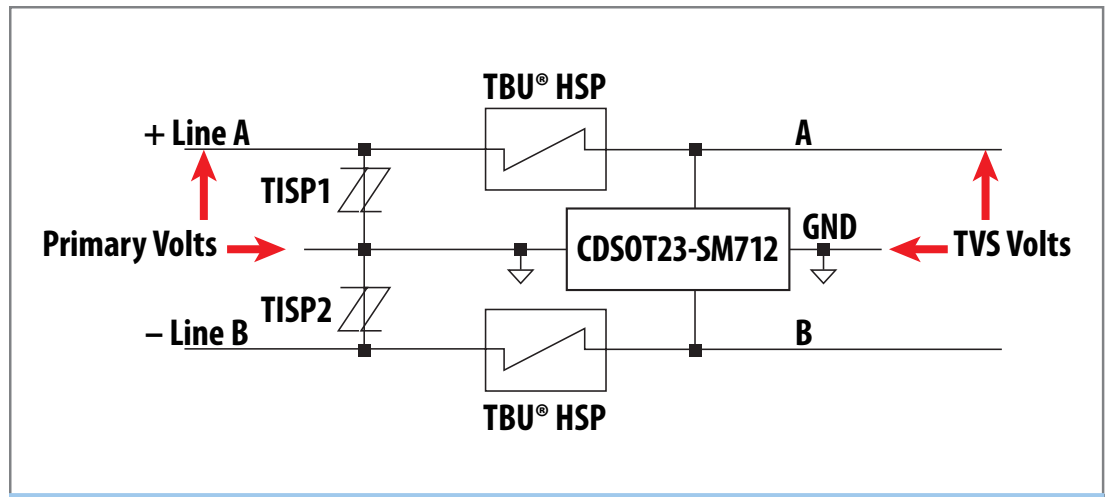

Figure 4 - Bourns® TBU-RS Series TBU® HSP with Bourns® TISP® Overvoltage Protection



Designing Effective Circuit Protection for RS-485 and RS-422 Applications

MULTI-STAGE CIRCUIT PROTECTION PERFORMANCE

Figures 5 through 8 demonstrate various levels of protection as shown in Figure 4 with the addition of actual Bourns lab test data using the $8 \times 20 \mu\text{s}$ standard test waveform as the surge generator input.



Bourns® TBU-RS Series
TBU® High-Speed Protectors



Bourns® TISP® Thyristor Surge
Protectors



Bourns® Gas Discharge Tubes (GDTs)



Bourns® GMOV™ / IsoMOV™
Hybrid Protection Components



Bourns® Metal Oxide Varistors (MOVs)

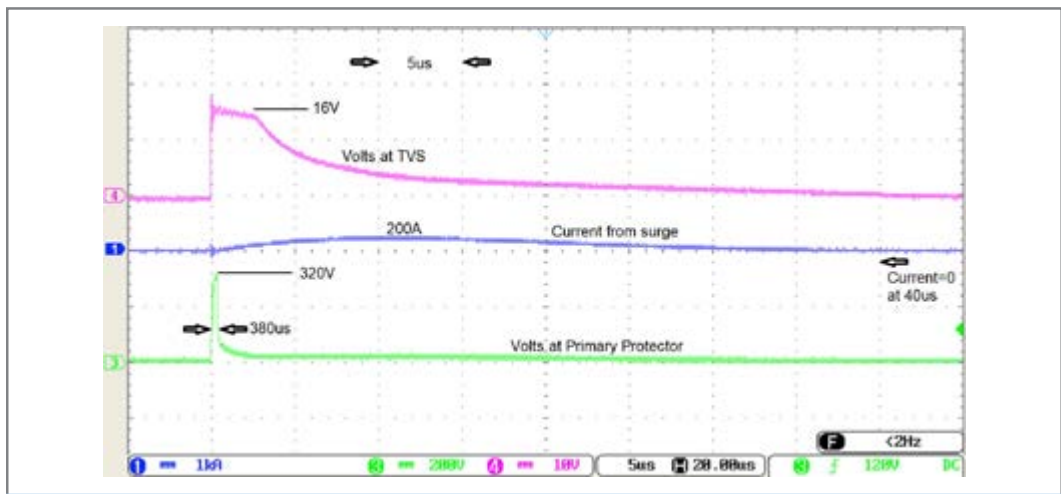

Figure 5 - A 500 V surge with Model TISP4350H3BJR as primary protector.

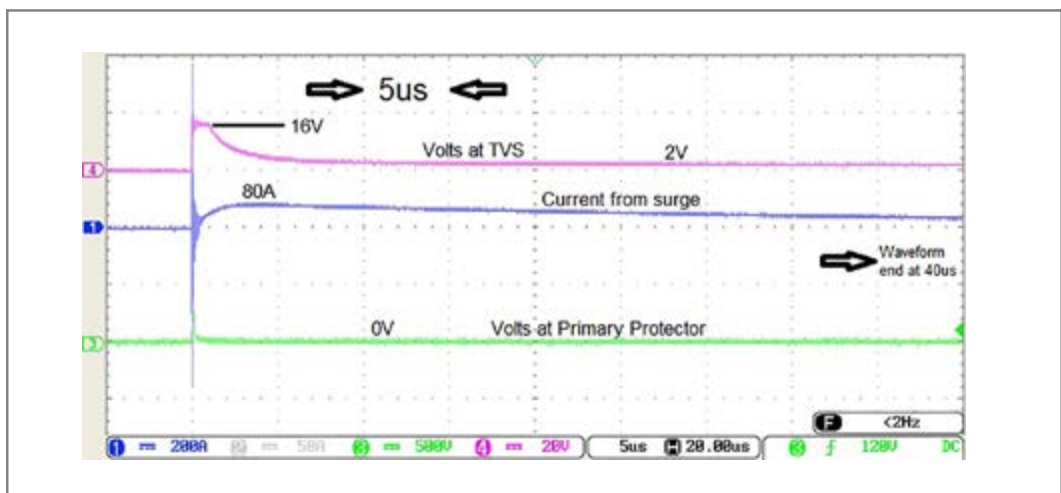

Figure 6 - A 1000 V surge with Model TISP4350H3BJR as primary protector.



Designing Effective Circuit Protection for RS-485 and RS-422 Applications

MULTI-STAGE CIRCUIT PROTECTION PERFORMANCE (Continued)



Bourns® TBU-RS Series
TBU® High-Speed Protectors



Bourns® TISP® Thyristor Surge
Protectors



Bourns® Gas Discharge Tubes (GDTs)



Bourns® GMOV™ / IsoMOV™
Hybrid Protection Components



Bourns® Metal Oxide Varistors (MOVs)

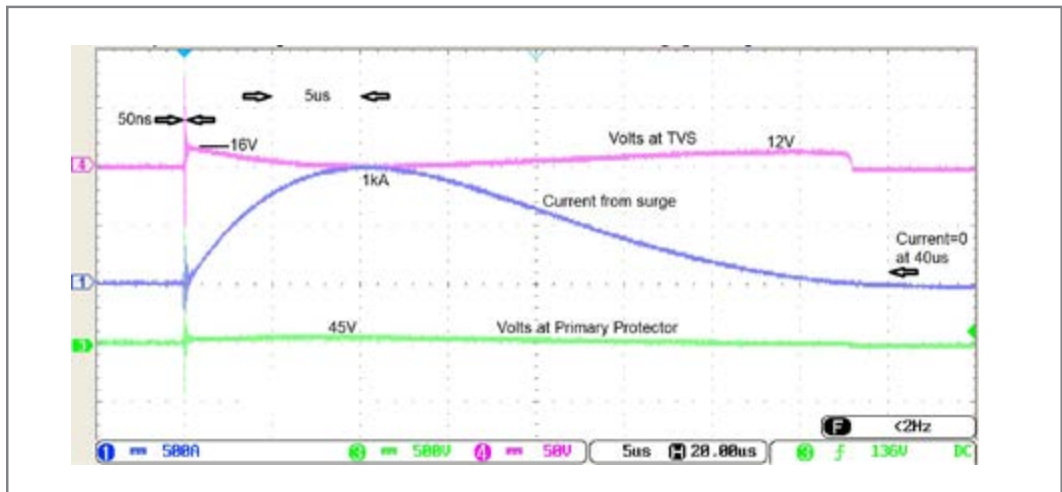

Figure 7 - A 2000 V surge with GDT 2030-23T-SM-RPLF as primary protector.

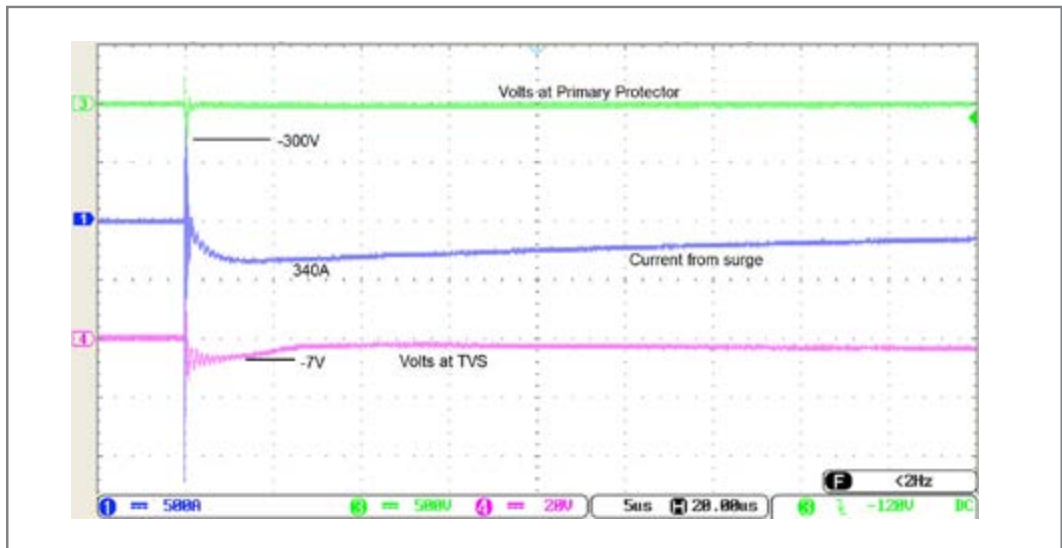

Figure 8 - A 4000 V surge with Model TISP4350J3BJR as primary protector.



Designing Effective Circuit Protection for RS-485 and RS-422 Applications



*Bourns® TBU-RS Series
TBU® High-Speed Protectors*



*Bourns® TISP® Thyristor Surge
Protectors*



Bourns® Gas Discharge Tubes (GDTs)



*Bourns® GMOV™ / IsoMOV™
Hybrid Protection Components*



Bourns® Metal Oxide Varistors (MOVs)



CIRCUIT PROTECTION ADVANCEMENTS FROM BOURNS

Bourns® TBU-RS Series TBU® HSPs offer exceptional protection against common RS-485 and RS-422 system threats including transients due to environmental factors, ESD from operator handling of wiring and interfaces, or miswiring and installation faults that happen as the result of human error. With all of the threats and performance considerations with which designers must contend, Bourns has developed a cost-effective way to reliably protect RS-485 and RS-422 interfaces.

Delivering associated overvoltage protection to ground from each line, the Bourns® TBU-RS Series TBU® HSP provides a solution to ensure that excess voltage can be shunted to ground or be clamped at safe voltages. The simplicity of its use provides inherent coordination with peripheral circuitry and fewer variables for the designer to consider. And by combining the TBU-RS Series HSP along with other Bourns® TISP®, MOV, GDT, GMOV™ or IsoMOV™ protection devices, designers get a comprehensive protection solution that gives them accurate, sub-microsecond response benefits.

Bourns is committed to continued technology advancements that address protection needs in a range of applications. Serving diverse markets, Bourns has demonstrated its leadership in defining future circuit protection solutions with proven excellence in design backed by superior customer service.

ADDITIONAL RESOURCES

Bourns® Circuit Protection Product Portfolio:
<https://www.bourns.com/products/circuit-protection>

Bourns® Circuit Protection Resource Library:
<https://www.bourns.com/resources/technical-library/library-documents/circuit-protection-technical-library>

Bourns® Circuit Protection Product Training Modules:
<https://www.bourns.com/resources/training/circuit-protection>

www.bourns.com

BOURNS®

Americas: Tel +1-951 781-5500
Email americus@bourns.com

EMEA: Tel +36 88 885 877
Email eurocus@bourns.com

Asia-Pacific: Tel +886-2 256 241 17
Email asiacus@bourns.com

COPYRIGHT© 2021 • BOURNS, INC. • 08/21 • e/FU2102

"Bourns", "TBU" and "TISP" are registered trademarks of Bourns, Inc. in the U.S. and other countries.

"GMOV" and "IsoMOV" are trademarks of Bourns, Inc.