

# CS8101

## Micropower 5.0 V, 100 mA Low Dropout Linear Regulator with $\overline{\text{RESET}}$ and $\overline{\text{ENABLE}}$

The CS8101 is a precision 5.0 V micropower voltage regulator with very low quiescent current (70  $\mu\text{A}$  typ at 100  $\mu\text{A}$  load). The 5.0 V output is accurate within  $\pm 2.0\%$  and supplies 100 mA of load current with a typical dropout voltage of only 400 mV. Microprocessor control logic includes an  $\overline{\text{ENABLE}}$  input and an active  $\overline{\text{RESET}}$ . This combination of low quiescent current, outstanding regulator performance and control logic makes the CS8101 ideal for any battery operated, microprocessor controlled equipment.

The active  $\overline{\text{RESET}}$  circuit includes hysteresis, and operates correctly at an output voltage as low as 1.0 V. The  $\overline{\text{RESET}}$  function is activated during the power up sequence or during normal operation if the output voltage drops outside the regulation limits by more than 200 mV typ. The logic level compatible  $\overline{\text{ENABLE}}$  input allows the user to put the regulator into a shutdown mode where it draws only 20  $\mu\text{A}$  typical of quiescent current.

The regulator is protected against reverse battery, short circuit, over voltage, and thermal overload conditions. The device can withstand load dump transients making it suitable for use in automotive environments.

The CS8101 is functionally equivalent to the National Semiconductor LP2951 series low current regulators.

### Features

- 5.0 V  $\pm 2.0\%$  Output
- Low 70  $\mu\text{A}$  Quiescent Current
- Active  $\overline{\text{RESET}}$
- $\overline{\text{ENABLE}}$  Input for ON/OFF and Active/Sleep Mode Control
- 100 mA Output Current Capability
- Fault Protection
  - +60 V Peak Transient Voltage
  - -15 V Reverse Voltage Short Circuit Thermal Overload
- Low Reverse Current (Output to Input)
- Internally Fused Leads Available in SO-20 WB Package
- These are Pb-Free Devices



ON Semiconductor®

<http://onsemi.com>

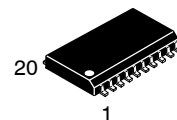

SO-20 WB  
DWF SUFFIX  
CASE 751D



SOIC-8  
D SUFFIX  
CASE 751

### ORDERING INFORMATION

See detailed ordering and shipping information in the package dimensions section on page 9 of this data sheet.

### DEVICE MARKING INFORMATION

See general marking information in the device marking section on page 9 of this data sheet.

# CS8101

## PIN CONNECTIONS

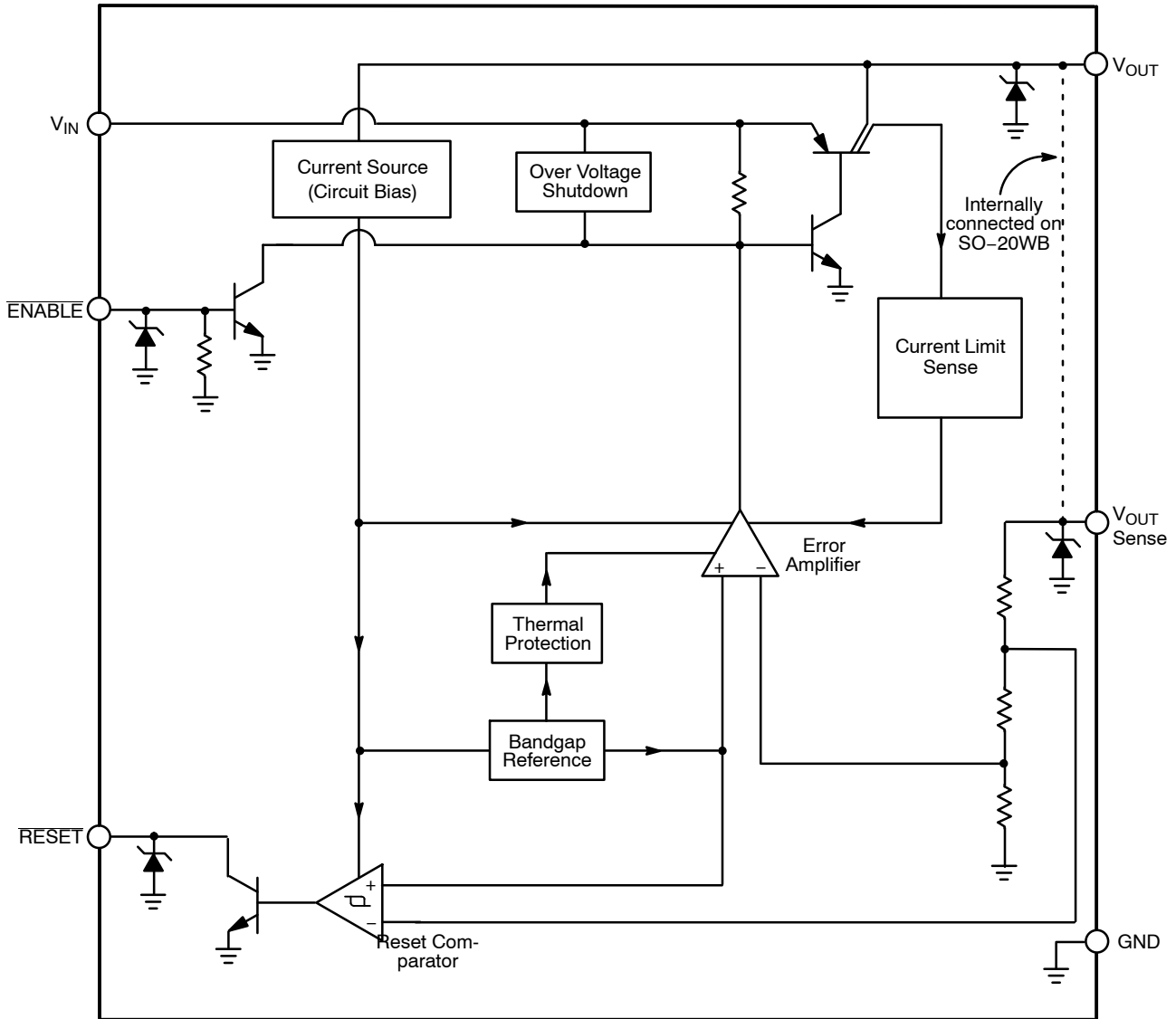
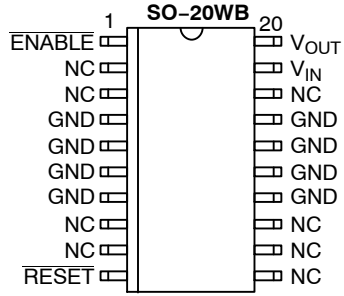
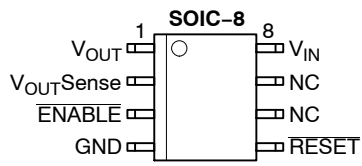

Figure 1. Block Diagram

# CS8101

## MAXIMUM RATINGS\*

Rating	Value	Unit
Power Dissipation	Internally Limited	–
Peak Transient Voltage (46 V Load Dump @ $V_{IN} = 14$ V)	–15, 60	V
Operating DC Voltage	30	V
$\overline{ENABLE}$ (Up to $V_{IN}$ with external resistor)	10	V
Output Current	Internally Limited	–
ESD Susceptibility (Human Body Model)	2.0	kV
ESD Susceptibility (Machine Model)	200	V
Operating Temperature	–40 to +125	°C
Junction Temperature Range	–40 to +150	°C
Storage Temperature Range	–55 to +150	°C
Lead Temperature Soldering:	Wave Solder (through hole styles only) (Note 1) Reflow (SMD styles only) (Notes 2 & 3)	260 peak 240 peak °C °C

Maximum ratings are those values beyond which device damage can occur. Maximum ratings applied to the device are individual stress limit values (not normal operating conditions) and are not valid simultaneously. If these limits are exceeded, device functional operation is not implied, damage may occur and reliability may be affected.

1. 10 second maximum.
2. 60 second maximum above 183°C.
3. –5°C / +0°C allowable conditions.

\*The maximum package power dissipation must be observed.

**ELECTRICAL CHARACTERISTICS** ( $6.0$  V  $\leq V_{IN} \leq 26$  V;  $I_{OUT} = 1.0$  mA;  $-40 \leq T_A \leq 125$ ,  $-40^\circ\text{C} \leq T_J \leq 150^\circ\text{C}$ , unless otherwise noted.)

Characteristic	Test Conditions	Min	Typ	Max	Unit
<b>Output Stage</b>					
Output Voltage, $V_{OUT}$	$9.0$ V $< V_{IN} < 16$ V, $100$ $\mu$ A $\leq I_{OUT} \leq 100$ mA	4.90	5.00	5.10	V
	$6.0$ V $< V_{IN} < 26$ V, $100$ $\mu$ A $\leq I_{OUT} \leq 100$ mA	4.85	5.00	5.15	V
Dropout Voltage ( $V_{IN} - V_{OUT}$ )	$I_{OUT} = 100$ mA	–	400	600	mV
	$I_{OUT} = 100$ $\mu$ A	–	100	150	mV
Load Regulation	$V_{IN} = 14$ V, $100$ $\mu$ A $\leq I_{OUT} \leq 100$ mA	–	5.0	50	mV
Line Regulation	$6.0 < V < 26$ V, $I_{OUT} = 1.0$ mA	–	5.0	50	mV
Quiescent Current, ( $I_Q$ ) Active Mode	$I_{OUT} = 100$ $\mu$ A, $V_{IN} = 6.0$ V	–	70	140	$\mu$ A
	$I_{OUT} = 50$ mA	–	4.0	6.0	mA
	$I_{OUT} = 100$ mA	–	12	20	mA
Quiescent Current, ( $I_Q$ ) Sleep Mode	$V_{OUT} = \text{OFF}$ , $V_{IN} = 6.0$ V, $\sqrt{ENABLE} = 2.0$ V	–	20	50	$\mu$ A
Ripple Rejection	$7.0 \leq V_{IN} \leq 17$ V, $I_{OUT} = 100$ mA, $f = 120$ Hz	60	75	–	dB
Current Limit	–	105	200	–	mA
Short Circuit Output Current	$V_{OUT} = 0$ V	25	125	–	mA
Thermal Shutdown	–	150	180	–	°C
Overvoltage Shutdown	$V_{OUT} \leq 1.0$ V	30	34	38	V
Reverse Current	$V_{OUT} = 5.0$ V, $V_{IN} = 0$ V	–	100	200	$\mu$ A

# CS8101

**ELECTRICAL CHARACTERISTICS (continued)** ( $6.0\text{ V} \leq V_{IN} \leq 26\text{ V}$ ;  $I_{OUT} = 1.0\text{ mA}$ ;  $-40 \leq T_A \leq 125$ ,  $-40^\circ\text{C} \leq T_J \leq 150^\circ\text{C}$ , unless otherwise noted.)

Characteristic	Test Conditions	Min	Typ	Max	Unit
<b>ENABLE Input (<math>\overline{\text{ENABLE}}</math>)</b>					
Threshold HIGH LOW	$(V_{OUT\ OFF})$	–	1.4	2.0	V
	$(V_{OUT\ ON})$	0.6	1.4	–	V
Input Current	$V_{\overline{\text{ENABLE}}} = 2.4\text{ V}$	–	30	100	$\mu\text{A}$

## Reset Functions ( $\overline{\text{RESET}}$ )

$\overline{\text{RESET}}$ Threshold HIGH ( $V_{RH}$ ) LOW ( $V_{RL}$ )	$V_{OUT}$ Increasing	4.525	4.75	$V_{OUT} - 0.05$	V
	$V_{OUT}$ Decreasing	4.500	4.70	$V_{OUT} - 0.075$	V
$\overline{\text{RESET}}$ Hysteresis	(HIGH – LOW)	25	50	100	mV
Reset Output Leakage $\overline{\text{RESET}} = \text{HIGH}$	$V_{OUT} \geq V_{RH}$	–	–	25	$\mu\text{A}$
Output Voltage Low ( $V_{RLO}$ ) Low ( $V_{RPEAK}$ )	$1.0\text{ V} \leq V_{OUT} \leq V_{RL}$ , $R_{\overline{\text{RESET}}} = 10\text{ k}$	–	0.1	0.4	V
	$V_{OUT}$ , Power up, Power down, $R_{\overline{\text{RESET}}} = 10\text{ k}$	–	0.6	1.0	V

## PACKAGE LEAD DESCRIPTION

PACKAGE LEAD #		LEAD SYMBOL	FUNCTION
SO-20 WB	SOIC-8		
20	1	$V_{OUT}$	5.0 V, $\pm 2.0\%$ , 100 mA output.
–	2	$V_{OUT\ SENSE}$	Kelvin connection which allows remote sensing of output voltage for improved regulation. If remote sensing is not required, connect to $V_{OUT}$ .
1	3	$\overline{\text{ENABLE}}$	Logic level switches output off when toggled HIGH.
4, 5, 6, 7 14, 15, 16, 17	4	GND	Ground. All GND leads must be connected to Ground.
10	5	$\overline{\text{RESET}}$	Active reset (accurate to $V_{OUT} \geq 1.0\text{ V}$ )
2, 3, 8, 9, 11, 12, 13, 18	6,7	NC	No Connection. True no-connect (i.e. is floating)
19	8	$V_{IN}$	Input voltage.

TYPICAL PERFORMANCE CHARACTERISTICS

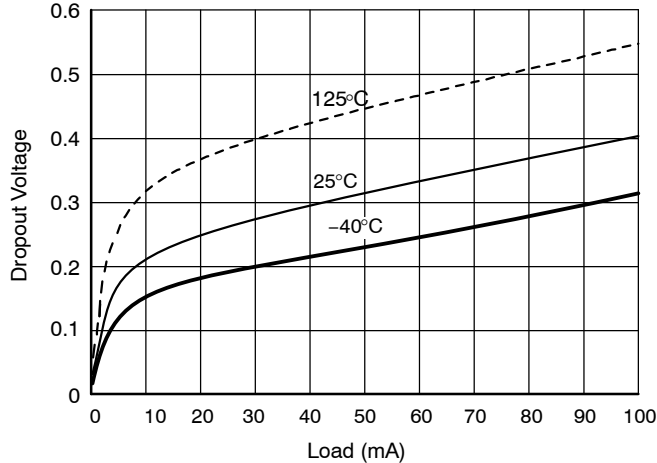

Figure 2. CS8101 Dropout Voltage vs. Load Over Temperature

CIRCUIT DESCRIPTION

VOLTAGE REFERENCE AND OUTPUT CIRCUITRY

Output Stage Protection

The output stage is protected against overvoltage, short circuit and thermal runaway conditions (Figure 3).

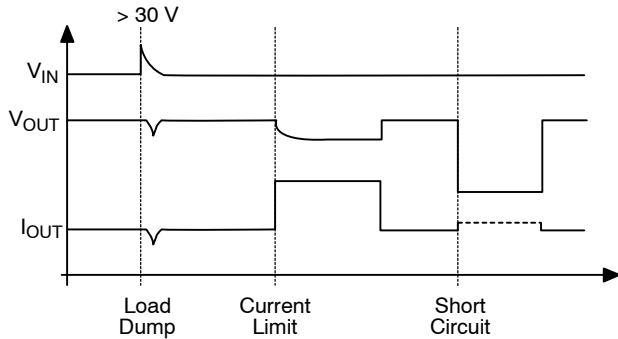

Figure 3. Typical Circuit Waveforms for Output Stage Protection

If the input voltage rises above 30 V (e.g. load dump), the output shuts down. This response protects the internal circuitry and enables the IC to survive unexpected voltage transients.

Should the junction temperature of the power device exceed 180°C (typ) the load current capability is reduced thereby preventing thermal overload. This thermal management function is an effective means to prevent die overheating since the load current is the principle heat source in the IC.

REGULATOR CONTROL FUNCTIONS

The CS8101 contains two microprocessor compatible control functions:  $\overline{\text{ENABLE}}$  and  $\overline{\text{RESET}}$  (Figure 4).

For 7.0 V <  $V_{\text{IN}}$  < 26 V

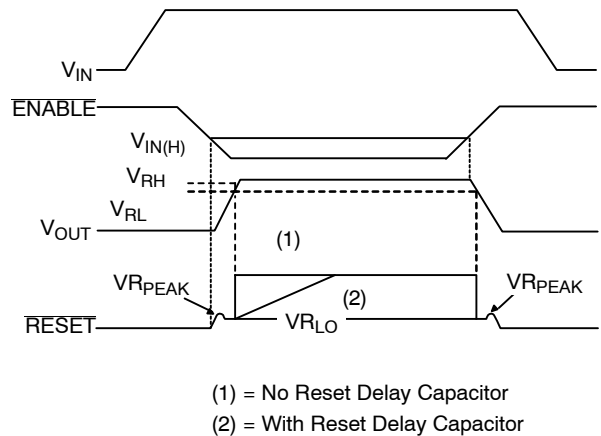

Figure 4. Circuit Waveform

$\overline{\text{ENABLE}}$  Function

The  $\overline{\text{ENABLE}}$  function switches the output transistor ON and OFF. When the voltage on the  $\overline{\text{ENABLE}}$  lead exceeds 1.4 V typ, the output pass transistor turns off, leaving a high impedance facing the load. The IC will remain in Sleep mode, drawing only 50  $\mu\text{A}$ , until the voltage on this input drops below the  $\overline{\text{ENABLE}}$  threshold.

$\overline{\text{RESET}}$  Function

A  $\overline{\text{RESET}}$  signal (low voltage) is generated as the IC powers up until  $V_{\text{OUT}}$  is within 250 mV of the regulated output voltage, or when  $V_{\text{OUT}}$  drops out of regulation, and is lower than 300 mV below the regulated output voltage. A hysteresis of 50 mV is included in the function to minimize oscillations.

## CS8101

The  $\overline{\text{RESET}}$  output is an open collector NPN transistor, controlled by a low voltage detection circuit. The circuit is functionally independent of the rest of the IC thereby guaranteeing that the  $\overline{\text{RESET}}$  signal is valid for  $V_{\text{OUT}}$  as low as 1.0 V.

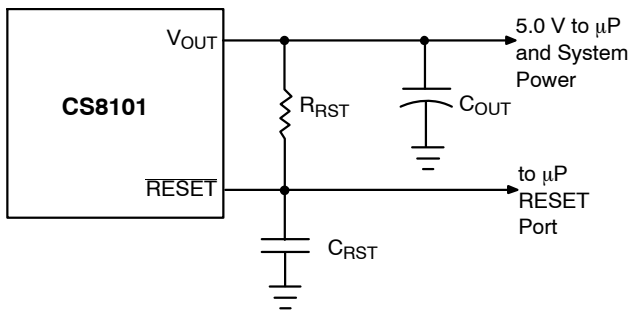

**Figure 5. RC Network for  $\overline{\text{RESET}}$  Delay**

An external RC network on the lead (Figure 5) provides a sufficiently long delay for most microprocessor based applications. RC values can be chosen using the following formula:

$$R_{\text{TOT}}C_{\text{RST}} = \left[ \frac{-t_{\text{Delay}}}{\ln\left(\frac{V_{\text{T}} - V_{\text{OUT}}}{V_{\text{RST}} - V_{\text{OUT}}}\right)} \right]$$

where:

$R_{\text{RST}}$  =  $\overline{\text{RESET}}$  Delay resistor

$R_{\text{IN}}$  =  $\mu\text{P}$  port impedance

$R_{\text{TOT}}$  =  $R_{\text{RST}}$  in parallel with  $R_{\text{IN}}$

$C_{\text{RST}}$  =  $\overline{\text{RESET}}$  Delay capacitor

$t_{\text{Delay}}$  = desired delay time

$V_{\text{RST}}$  =  $V_{\text{SAT}}$  of  $\overline{\text{RESET}}$  lead (0.7 V @ turn - ON)

$V_{\text{T}}$  =  $\overline{\text{RESET}}$  threshold.

The circuit depicted in Figure 6 lets the microprocessor control its power source, the CS8101 regulator. An I/O port on the  $\mu\text{P}$  and the SWITCH port are used to drive the base of Q1. When Q1 is driven into saturation, the voltage on the  $\overline{\text{ENABLE}}$  lead falls below its lower threshold. The regulator's output is enabled. When the drive current is removed, the voltage on the  $\overline{\text{ENABLE}}$  lead rises, the output is switched off and the IC moves into Sleep mode where it draws 50  $\mu\text{A}$  (max).

By coupling these two controls with the  $\overline{\text{ENABLE}}$  lead, the system has added flexibility. Once the system is running, the state of the SWITCH is irrelevant as long as the I/O port continues to drive Q1. The microprocessor can turn off its own power by withdrawing drive current, once the SWITCH is open. This software control at the I/O port allows the microprocessor to finish key housekeeping functions before power is removed.

The logic options are summarized in Table 1.

**Table 1. Logic Control of CS8101 Output**

Microprocessor I/O Drive	Switch	$\overline{\text{ENABLE}}$	Output
ON	Closed	LOW	ON
	Open	LOW	ON
OFF	Closed	LOW	ON
	Open	HIGH	OFF

The I/O port of the microprocessor typically provides 50  $\mu\text{A}$  to Q1. In automotive applications the SWITCH is connected to the ignition switch.

APPLICATION NOTES

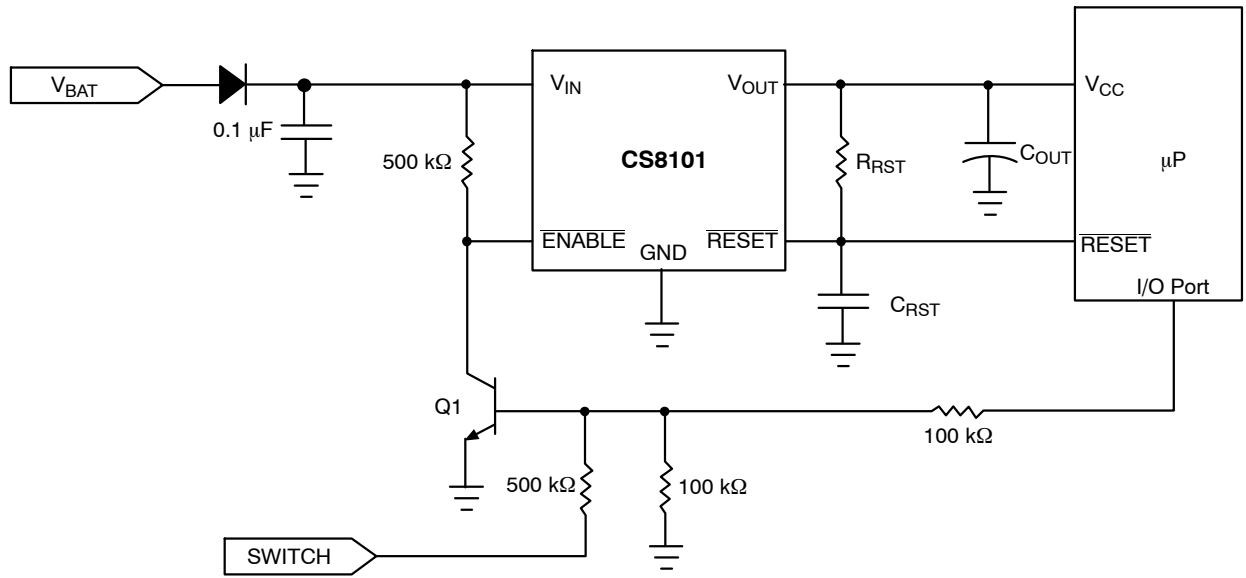

Figure 6. Microprocessor Control of CS8101 Using External Switching Transistor Q1

The  $\overline{\text{ENABLE}}$  pin of the CS8101 can be tied to the battery voltage provided a series resistor is used as shown in Figure 7. The maximum allowed voltage on the  $\overline{\text{ENABLE}}$  pin without the resistor is 10 V. Direct voltages greater than 10 V applied to the pin without the series resistor may damage the device. The system designer should note the turn-on threshold (typ 1.4 V) is on the  $\overline{\text{ENABLE}}$  pin. The threshold will be higher on the other side of  $R_{\text{ENABLE}}$ .

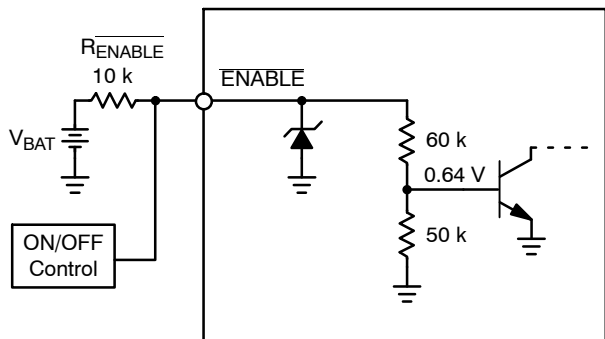
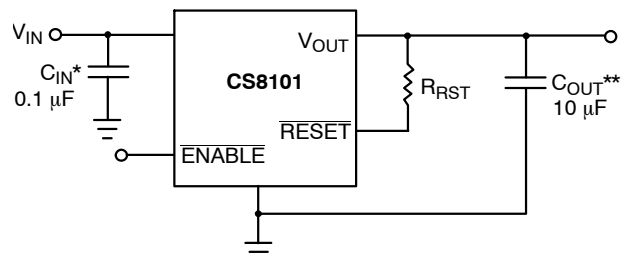

Figure 7. Using the  $\overline{\text{ENABLE}}$  pin with  $V_{\text{BAT}}$

STABILITY CONSIDERATIONS

The output or compensation capacitor helps determine three main characteristics of a linear regulator: start-up delay, load transient response and loop stability.



\* $C_{\text{IN}}$  required if regulator is located far from the power supply filter.  
 \*\* $C_{\text{OUT}}$  required for stability. Capacitor must operate at minimum temperature expected.

Figure 8. Test and Application Circuit Showing Output Compensation

The capacitor value and type should be based on cost, availability, size and temperature constraints. A tantalum or aluminum electrolytic capacitor is best, since a film or ceramic capacitor with almost zero ESR can cause instability. The aluminum electrolytic capacitor is the least expensive solution, but, if the circuit operates at low temperatures ( $-25^{\circ}\text{C}$  to  $-40^{\circ}\text{C}$ ), both the value and ESR of the capacitor will vary considerably. The capacitor manufacturers data sheet usually provides this information.

The value for the output capacitor  $C_{\text{OUT}}$  shown in Figure 8 should work for most applications, however it is not necessarily the optimized solution.

To determine an acceptable value for  $C_{OUT}$  for a particular application, start with a tantalum capacitor of the recommended value and work towards a less expensive alternative part.

**Step 1:** Place the completed circuit with a tantalum capacitor of the recommended value in an environmental chamber at the lowest specified operating temperature and monitor the outputs with an oscilloscope. A decade box connected in series with the capacitor will simulate the higher ESR of an aluminum capacitor. Leave the decade box outside the chamber, the small resistance added by the longer leads is negligible.

**Step 2:** With the input voltage at its maximum value, increase the load current slowly from zero to full load while observing the output for any oscillations. If no oscillations are observed, the capacitor is large enough to ensure a stable design under steady state conditions.

**Step 3:** Increase the ESR of the capacitor from zero using the decade box and vary the load current until oscillations appear. Record the values of load current and ESR that cause the greatest oscillation. This represents the worst case load conditions for the regulator at low temperature.

**Step 4:** Maintain the worst case load conditions set in step 3 and vary the input voltage until the oscillations increase. This point represents the worst case input voltage conditions.

**Step 5:** If the capacitor is adequate, repeat steps 3 and 4 with the next smaller valued capacitor. A smaller capacitor will usually cost less and occupy less board space. If the output oscillates within the range of expected operating conditions, repeat steps 3 and 4 with the next larger standard capacitor value.

**Step 6:** Test the load transient response by switching in various loads at several frequencies to simulate its real working environment. Vary the ESR to reduce ringing.

**Step 7:** Raise the temperature to the highest specified operating temperature. Vary the load current as instructed in step 5 to test for any oscillations.

Once the minimum capacitor value with the maximum ESR is found, a safety factor should be added to allow for the tolerance of the capacitor and any variations in regulator performance. Most good quality aluminum electrolytic capacitors have a tolerance of  $\pm 20\%$  so the minimum value found should be increased by at least 50% to allow for this tolerance plus the variation which will occur at low temperatures. The ESR of the capacitor should be less than 50% of the maximum allowable ESR found in step 3 above.

**CALCULATING POWER DISSIPATION IN A SINGLE OUTPUT LINEAR REGULATOR**

The maximum power dissipation for a single output regulator (Figure 9) is:

$$P_{D(max)} = (V_{IN(max)} - V_{OUT(min)})I_{OUT(max)} + V_{IN(max)}I_Q \quad (1)$$

where:

- $V_{IN(max)}$  is the maximum input voltage,
- $V_{OUT(min)}$  is the minimum output voltage,
- $I_{OUT(max)}$  is the maximum output current for the application, and
- $I_Q$  is the quiescent current the regulator consumes at  $I_{OUT(max)}$ .

Once the value of  $P_{D(max)}$  is known, the maximum permissible value of  $R_{\theta JA}$  can be calculated:

$$R_{\theta JA} = \frac{150^{\circ}C - T_A}{P_D} \quad (2)$$

The value of  $R_{\theta JA}$  can then be compared with those in the package section of the data sheet. Those packages with  $R_{\theta JA}$ 's less than the calculated value in equation 2 will keep the die temperature below 150°C.

In some cases, none of the packages will be sufficient to dissipate the heat generated by the IC, and an external heatsink will be required.

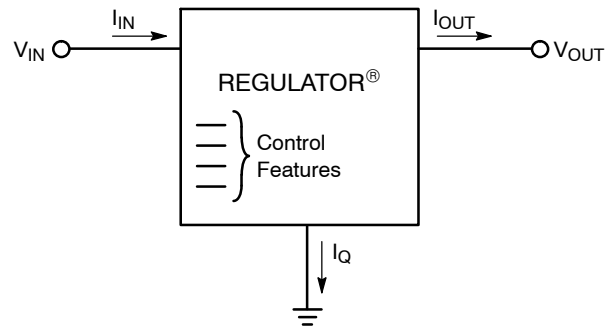

**Figure 9. Single Output Regulator With Key Performance Parameters Labeled**

**HEAT SINKS**

A heat sink effectively increases the surface area of the package to improve the flow of heat away from the IC and into the surrounding air.

Each material in the heat flow path between the IC and the outside environment will have a thermal resistance. Like series electrical resistances, these resistances are summed to determine the value of  $R_{\theta JA}$ .

$$R_{\theta JA} = R_{\theta JC} + R_{\theta CS} + R_{\theta SA} \quad (3)$$

where:

- $R_{\theta JC}$  = the junction-to-case thermal resistance,
- $R_{\theta CS}$  = the case-to-heatsink thermal resistance, and
- $R_{\theta SA}$  = the heatsink-to-ambient thermal resistance.

$R_{\theta JC}$  appears in the package section of the data sheet. Like  $R_{\theta JA}$ , it is a function of package type.  $R_{\theta CS}$  and  $R_{\theta SA}$  are functions of the package type, heatsink and the interface between them. These values appear in heat sink data sheets of heat sink manufacturers.



# CS8101

## DEVICE ORDERING INFORMATION\*

Device	Package	Shipping†
CS8101YD8G	SOIC-8 (Pb-Free)	98 Units/Rail
CS8101YDR8G	SOIC-8 (Pb-Free)	2500/Tape & Reel
CS8101YDWF20G	SO-20 WB (Pb-Free)	38 Units/Tube
CS8101YDWFR20G	SO-20 WB (Pb-Free)	1000/Tape & Reel

\*Contact your local sales representative for D<sup>2</sup>PAK package option.

†For information on tape and reel specifications, including part orientation and tape sizes, please refer to our Tape and Reel Packaging Specifications Brochure, BRD8011/D.

## MARKING DIAGRAMS

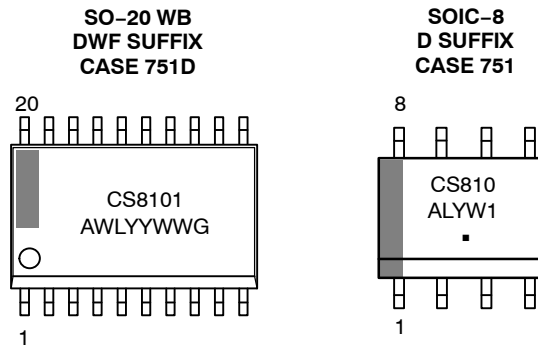

CS8101 = Specific Device Code  
 A = Assembly Location  
 WL, L = Wafer Lot  
 YY, Y = Year  
 WW, W = Work Week  
 G = Pb-Free Package  
 ■ = Pb-Free Package

# MECHANICAL CASE OUTLINE PACKAGE DIMENSIONS



SCALE 1:1

SOIC-8 NB  
CASE 751-07  
ISSUE AK

DATE 16 FEB 2011



- NOTES:
1. DIMENSIONING AND TOLERANCING PER ANSI Y14.5M, 1982.
  2. CONTROLLING DIMENSION: MILLIMETER.
  3. DIMENSION A AND B DO NOT INCLUDE MOLD PROTRUSION.
  4. MAXIMUM MOLD PROTRUSION 0.15 (0.006) PER SIDE.
  5. DIMENSION D DOES NOT INCLUDE DAMBAR PROTRUSION. ALLOWABLE DAMBAR PROTRUSION SHALL BE 0.127 (0.005) TOTAL IN EXCESS OF THE D DIMENSION AT MAXIMUM MATERIAL CONDITION.
  6. 751-01 THRU 751-06 ARE OBSOLETE. NEW STANDARD IS 751-07.

DIM	MILLIMETERS		INCHES	
	MIN	MAX	MIN	MAX
A	4.80	5.00	0.189	0.197
B	3.80	4.00	0.150	0.157
C	1.35	1.75	0.053	0.069
D	0.33	0.51	0.013	0.020
G	1.27 BSC		0.050 BSC	
H	0.10	0.25	0.004	0.010
J	0.19	0.25	0.007	0.010
K	0.40	1.27	0.016	0.050
M	0°	8°	0°	8°
N	0.25	0.50	0.010	0.020
S	5.80	6.20	0.228	0.244

### SOLDERING FOOTPRINT\*



\*For additional information on our Pb-Free strategy and soldering details, please download the ON Semiconductor Soldering and Mounting Techniques Reference Manual, SOLDERRM/D.

### GENERIC MARKING DIAGRAM\*



XXXXXX = Specific Device Code  
A = Assembly Location  
L = Wafer Lot  
Y = Year  
W = Work Week  
▪ = Pb-Free Package

XXXXXX = Specific Device Code  
A = Assembly Location  
Y = Year  
WW = Work Week  
▪ = Pb-Free Package

\*This information is generic. Please refer to device data sheet for actual part marking. Pb-Free indicator, "G" or microdot "▪", may or may not be present. Some products may not follow the Generic Marking.

### STYLES ON PAGE 2

DOCUMENT NUMBER:	98ASB42564B	Electronic versions are uncontrolled except when accessed directly from the Document Repository. Printed versions are uncontrolled except when stamped "CONTROLLED COPY" in red.
DESCRIPTION:	SOIC-8 NB	PAGE 1 OF 2

onsemi and ONsemi are trademarks of Semiconductor Components Industries, LLC dba onsemi or its subsidiaries in the United States and/or other countries. onsemi reserves the right to make changes without further notice to any products herein. onsemi makes no warranty, representation or guarantee regarding the suitability of its products for any particular purpose, nor does onsemi assume any liability arising out of the application or use of any product or circuit, and specifically disclaims any and all liability, including without limitation special, consequential or incidental damages. onsemi does not convey any license under its patent rights nor the rights of others.

**SOIC-8 NB**  
**CASE 751-07**  
**ISSUE AK**

DATE 16 FEB 2011

- |   |  |  |  |
|---|--|--|--|
| <p>STYLE 1:<br/>         PIN 1. EMITTER<br/>         2. COLLECTOR<br/>         3. COLLECTOR<br/>         4. EMITTER<br/>         5. EMITTER<br/>         6. BASE<br/>         7. BASE<br/>         8. EMITTER</p>   | <p>STYLE 2:<br/>         PIN 1. COLLECTOR, DIE, #1<br/>         2. COLLECTOR, #1<br/>         3. COLLECTOR, #2<br/>         4. COLLECTOR, #2<br/>         5. BASE, #2<br/>         6. EMITTER, #2<br/>         7. BASE, #1<br/>         8. EMITTER, #1</p>               | <p>STYLE 3:<br/>         PIN 1. DRAIN, DIE #1<br/>         2. DRAIN, #1<br/>         3. DRAIN, #2<br/>         4. DRAIN, #2<br/>         5. GATE, #2<br/>         6. SOURCE, #2<br/>         7. GATE, #1<br/>         8. SOURCE, #1</p>                            | <p>STYLE 4:<br/>         PIN 1. ANODE<br/>         2. ANODE<br/>         3. ANODE<br/>         4. ANODE<br/>         5. ANODE<br/>         6. ANODE<br/>         7. ANODE<br/>         8. COMMON CATHODE</p>   |
| <p>STYLE 5:<br/>         PIN 1. DRAIN<br/>         2. DRAIN<br/>         3. DRAIN<br/>         4. DRAIN<br/>         5. GATE<br/>         6. GATE<br/>         7. SOURCE<br/>         8. SOURCE</p>   | <p>STYLE 6:<br/>         PIN 1. SOURCE<br/>         2. DRAIN<br/>         3. DRAIN<br/>         4. SOURCE<br/>         5. SOURCE<br/>         6. GATE<br/>         7. GATE<br/>         8. SOURCE</p>  | <p>STYLE 7:<br/>         PIN 1. INPUT<br/>         2. EXTERNAL BYPASS<br/>         3. THIRD STAGE SOURCE<br/>         4. GROUND<br/>         5. DRAIN<br/>         6. GATE 3<br/>         7. SECOND STAGE Vd<br/>         8. FIRST STAGE Vd</p>                    | <p>STYLE 8:<br/>         PIN 1. COLLECTOR, DIE #1<br/>         2. BASE, #1<br/>         3. BASE, #2<br/>         4. COLLECTOR, #2<br/>         5. COLLECTOR, #2<br/>         6. EMITTER, #2<br/>         7. EMITTER, #1<br/>         8. COLLECTOR, #1</p>                              |
| <p>STYLE 9:<br/>         PIN 1. EMITTER, COMMON<br/>         2. COLLECTOR, DIE #1<br/>         3. COLLECTOR, DIE #2<br/>         4. EMITTER, COMMON<br/>         5. EMITTER, COMMON<br/>         6. BASE, DIE #2<br/>         7. BASE, DIE #1<br/>         8. EMITTER, COMMON</p> | <p>STYLE 10:<br/>         PIN 1. GROUND<br/>         2. BIAS 1<br/>         3. OUTPUT<br/>         4. GROUND<br/>         5. GROUND<br/>         6. BIAS 2<br/>         7. INPUT<br/>         8. GROUND</p>  | <p>STYLE 11:<br/>         PIN 1. SOURCE 1<br/>         2. GATE 1<br/>         3. SOURCE 2<br/>         4. GATE 2<br/>         5. DRAIN 2<br/>         6. DRAIN 2<br/>         7. DRAIN 1<br/>         8. DRAIN 1</p>   | <p>STYLE 12:<br/>         PIN 1. SOURCE<br/>         2. SOURCE<br/>         3. SOURCE<br/>         4. GATE<br/>         5. DRAIN<br/>         6. DRAIN<br/>         7. DRAIN<br/>         8. DRAIN</p>   |
| <p>STYLE 13:<br/>         PIN 1. N.C.<br/>         2. SOURCE<br/>         3. SOURCE<br/>         4. GATE<br/>         5. DRAIN<br/>         6. DRAIN<br/>         7. DRAIN<br/>         8. DRAIN</p>  | <p>STYLE 14:<br/>         PIN 1. N-SOURCE<br/>         2. N-GATE<br/>         3. P-SOURCE<br/>         4. P-GATE<br/>         5. P-DRAIN<br/>         6. P-DRAIN<br/>         7. N-DRAIN<br/>         8. N-DRAIN</p>   | <p>STYLE 15:<br/>         PIN 1. ANODE 1<br/>         2. ANODE 1<br/>         3. ANODE 1<br/>         4. ANODE 1<br/>         5. CATHODE, COMMON<br/>         6. CATHODE, COMMON<br/>         7. CATHODE, COMMON<br/>         8. CATHODE, COMMON</p>               | <p>STYLE 16:<br/>         PIN 1. EMITTER, DIE #1<br/>         2. BASE, DIE #1<br/>         3. EMITTER, DIE #2<br/>         4. BASE, DIE #2<br/>         5. COLLECTOR, DIE #2<br/>         6. COLLECTOR, DIE #2<br/>         7. COLLECTOR, DIE #1<br/>         8. COLLECTOR, DIE #1</p> |
| <p>STYLE 17:<br/>         PIN 1. VCC<br/>         2. V2OUT<br/>         3. V1OUT<br/>         4. TXE<br/>         5. RXE<br/>         6. VEE<br/>         7. GND<br/>         8. ACC</p>  | <p>STYLE 18:<br/>         PIN 1. ANODE<br/>         2. ANODE<br/>         3. SOURCE<br/>         4. GATE<br/>         5. DRAIN<br/>         6. DRAIN<br/>         7. CATHODE<br/>         8. CATHODE</p>   | <p>STYLE 19:<br/>         PIN 1. SOURCE 1<br/>         2. GATE 1<br/>         3. SOURCE 2<br/>         4. GATE 2<br/>         5. DRAIN 2<br/>         6. MIRROR 2<br/>         7. DRAIN 1<br/>         8. MIRROR 1</p>   | <p>STYLE 20:<br/>         PIN 1. SOURCE (N)<br/>         2. GATE (N)<br/>         3. SOURCE (P)<br/>         4. GATE (P)<br/>         5. DRAIN<br/>         6. DRAIN<br/>         7. DRAIN<br/>         8. DRAIN</p>   |
| <p>STYLE 21:<br/>         PIN 1. CATHODE 1<br/>         2. CATHODE 2<br/>         3. CATHODE 3<br/>         4. CATHODE 4<br/>         5. CATHODE 5<br/>         6. COMMON ANODE<br/>         7. COMMON ANODE<br/>         8. CATHODE 6</p>  | <p>STYLE 22:<br/>         PIN 1. I/O LINE 1<br/>         2. COMMON CATHODE/VCC<br/>         3. COMMON CATHODE/VCC<br/>         4. I/O LINE 3<br/>         5. COMMON ANODE/GND<br/>         6. I/O LINE 4<br/>         7. I/O LINE 5<br/>         8. COMMON ANODE/GND</p> | <p>STYLE 23:<br/>         PIN 1. LINE 1 IN<br/>         2. COMMON ANODE/GND<br/>         3. COMMON ANODE/GND<br/>         4. LINE 2 IN<br/>         5. LINE 2 OUT<br/>         6. COMMON ANODE/GND<br/>         7. COMMON ANODE/GND<br/>         8. LINE 1 OUT</p> | <p>STYLE 24:<br/>         PIN 1. BASE<br/>         2. EMITTER<br/>         3. COLLECTOR/ANODE<br/>         4. COLLECTOR/ANODE<br/>         5. CATHODE<br/>         6. CATHODE<br/>         7. COLLECTOR/ANODE<br/>         8. COLLECTOR/ANODE</p>                                      |
| <p>STYLE 25:<br/>         PIN 1. VIN<br/>         2. N/C<br/>         3. REXT<br/>         4. GND<br/>         5. IOUT<br/>         6. IOUT<br/>         7. IOUT<br/>         8. IOUT</p>   | <p>STYLE 26:<br/>         PIN 1. GND<br/>         2. dv/dt<br/>         3. ENABLE<br/>         4. ILIMIT<br/>         5. SOURCE<br/>         6. SOURCE<br/>         7. SOURCE<br/>         8. VCC</p>  | <p>STYLE 27:<br/>         PIN 1. ILIMIT<br/>         2. OVLO<br/>         3. UVLO<br/>         4. INPUT+<br/>         5. SOURCE<br/>         6. SOURCE<br/>         7. SOURCE<br/>         8. DRAIN</p>  | <p>STYLE 28:<br/>         PIN 1. SW_TO_GND<br/>         2. DASIC_OFF<br/>         3. DASIC_SW_DET<br/>         4. GND<br/>         5. V_MON<br/>         6. VBULK<br/>         7. VBULK<br/>         8. VIN</p>  |
| <p>STYLE 29:<br/>         PIN 1. BASE, DIE #1<br/>         2. EMITTER, #1<br/>         3. BASE, #2<br/>         4. EMITTER, #2<br/>         5. COLLECTOR, #2<br/>         6. COLLECTOR, #2<br/>         7. COLLECTOR, #1<br/>         8. COLLECTOR, #1</p>                        | <p>STYLE 30:<br/>         PIN 1. DRAIN 1<br/>         2. DRAIN 1<br/>         3. GATE 2<br/>         4. SOURCE 2<br/>         5. SOURCE 1/DRAIN 2<br/>         6. SOURCE 1/DRAIN 2<br/>         7. SOURCE 1/DRAIN 2<br/>         8. GATE 1</p>                           |  |  |

<b>DOCUMENT NUMBER:</b>	<b>98ASB42564B</b>	Electronic versions are uncontrolled except when accessed directly from the Document Repository. Printed versions are uncontrolled except when stamped "CONTROLLED COPY" in red.
<b>DESCRIPTION:</b>	<b>SOIC-8 NB</b>	<b>PAGE 2 OF 2</b>

**onsemi** and **ONSEMI** are trademarks of Semiconductor Components Industries, LLC dba **onsemi** or its subsidiaries in the United States and/or other countries. **onsemi** reserves the right to make changes without further notice to any products herein. **onsemi** makes no warranty, representation or guarantee regarding the suitability of its products for any particular purpose, nor does **onsemi** assume any liability arising out of the application or use of any product or circuit, and specifically disclaims any and all liability, including without limitation special, consequential or incidental damages. **onsemi** does not convey any license under its patent rights nor the rights of others.

# MECHANICAL CASE OUTLINE PACKAGE DIMENSIONS



SCALE 1:1

SOIC-20 WB  
CASE 751D-05  
ISSUE H

DATE 22 APR 2015



NOTES:

1. DIMENSIONS ARE IN MILLIMETERS.
2. INTERPRET DIMENSIONS AND TOLERANCES PER ASME Y14.5M, 1994.
3. DIMENSIONS D AND E DO NOT INCLUDE MOLD PROTRUSION.
4. MAXIMUM MOLD PROTRUSION 0.15 PER SIDE.
5. DIMENSION B DOES NOT INCLUDE DAMBAR PROTRUSION. ALLOWABLE PROTRUSION SHALL BE 0.13 TOTAL IN EXCESS OF B DIMENSION AT MAXIMUM MATERIAL CONDITION.

DIM	MILLIMETERS	
	MIN	MAX
A	2.35	2.65
A1	0.10	0.25
b	0.35	0.49
c	0.23	0.32
D	12.65	12.95
E	7.40	7.60
e	1.27 BSC	
H	10.05	10.55
h	0.25	0.75
L	0.50	0.90
θ	0°	7°

RECOMMENDED  
SOLDERING FOOTPRINT\*



DIMENSIONS: MILLIMETERS

\*For additional information on our Pb-Free strategy and soldering details, please download the ON Semiconductor Soldering and Mounting Techniques Reference Manual, SOLDERRM/D.

GENERIC  
MARKING DIAGRAM\*

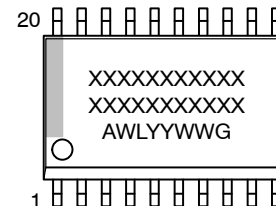

- XXXXXX = Specific Device Code
- A = Assembly Location
- WL = Wafer Lot
- YY = Year
- WW = Work Week
- G = Pb-Free Package

\*This information is generic. Please refer to device data sheet for actual part marking. Pb-Free indicator, "G" or microdot "▪", may or may not be present. Some products may not follow the Generic Marking.

DOCUMENT NUMBER:	98ASB42343B	Electronic versions are uncontrolled except when accessed directly from the Document Repository. Printed versions are uncontrolled except when stamped "CONTROLLED COPY" in red.
DESCRIPTION:	SOIC-20 WB	PAGE 1 OF 1

onsemi and ONSEMI are trademarks of Semiconductor Components Industries, LLC dba onsemi or its subsidiaries in the United States and/or other countries. onsemi reserves the right to make changes without further notice to any products herein. onsemi makes no warranty, representation or guarantee regarding the suitability of its products for any particular purpose, nor does onsemi assume any liability arising out of the application or use of any product or circuit, and specifically disclaims any and all liability, including without limitation special, consequential or incidental damages. onsemi does not convey any license under its patent rights nor the rights of others.

**onsemi**, **Onsemi**, and other names, marks, and brands are registered and/or common law trademarks of Semiconductor Components Industries, LLC dba "**onsemi**" or its affiliates and/or subsidiaries in the United States and/or other countries. **onsemi** owns the rights to a number of patents, trademarks, copyrights, trade secrets, and other intellectual property. A listing of **onsemi**'s product/patent coverage may be accessed at [www.onsemi.com/site/pdf/Patent-Marking.pdf](http://www.onsemi.com/site/pdf/Patent-Marking.pdf). **onsemi** reserves the right to make changes at any time to any products or information herein, without notice. The information herein is provided "as-is" and **onsemi** makes no warranty, representation or guarantee regarding the accuracy of the information, product features, availability, functionality, or suitability of its products for any particular purpose, nor does **onsemi** assume any liability arising out of the application or use of any product or circuit, and specifically disclaims any and all liability, including without limitation special, consequential or incidental damages. Buyer is responsible for its products and applications using **onsemi** products, including compliance with all laws, regulations and safety requirements or standards, regardless of any support or applications information provided by **onsemi**. "Typical" parameters which may be provided in **onsemi** data sheets and/or specifications can and do vary in different applications and actual performance may vary over time. All operating parameters, including "Typicals" must be validated for each customer application by customer's technical experts. **onsemi** does not convey any license under any of its intellectual property rights nor the rights of others. **onsemi** products are not designed, intended, or authorized for use as a critical component in life support systems or any FDA Class 3 medical devices or medical devices with a same or similar classification in a foreign jurisdiction or any devices intended for implantation in the human body. Should Buyer purchase or use **onsemi** products for any such unintended or unauthorized application, Buyer shall indemnify and hold **onsemi** and its officers, employees, subsidiaries, affiliates, and distributors harmless against all claims, costs, damages, and expenses, and reasonable attorney fees arising out of, directly or indirectly, any claim of personal injury or death associated with such unintended or unauthorized use, even if such claim alleges that **onsemi** was negligent regarding the design or manufacture of the part. **onsemi** is an Equal Opportunity/Affirmative Action Employer. This literature is subject to all applicable copyright laws and is not for resale in any manner.

## PUBLICATION ORDERING INFORMATION

### LITERATURE FULFILLMENT:

Email Requests to: [orderlit@onsemi.com](mailto:orderlit@onsemi.com)

**onsemi Website:** [www.onsemi.com](http://www.onsemi.com)

### TECHNICAL SUPPORT

**North American Technical Support:**

Voice Mail: 1 800-282-9855 Toll Free USA/Canada

Phone: 011 421 33 790 2910

**Europe, Middle East and Africa Technical Support:**

Phone: 00421 33 790 2910

For additional information, please contact your local Sales Representative